SLIGO COUNTY COUNCIL

PROVISION OF GROUP HOUSING AT ASH LANE CO. SLIGO

SCREENING FOR APPROPRIATE ASSESSMENT

AUGUST 2023

Sligo County Council,
County Hall,
Riverside,
Co. Sligo,



Jennings O'Donovan & Partners Ltd.,
Consulting Engineers,
Finisklin Business Park,
Sligo.
Tel.: 071 – 9161416
Fax: 071 – 9161080
e mail: info@jodireland.com
web: www.jodireland.com



JENNINGS O'DONOVAN & PARTNERS LIMITED
 Project, Civil and Structural Consulting Engineers,
 FINISKLIN BUSINESS PARK,
 SLIGO,
 IRELAND.



Telephone (071) 91 61416
 Fax (071) 91 61080

Email info@jodireland.com
 Web Site www.jodireland.com

DOCUMENT APPROVAL

| | | |
|------------------------|---|------|
| PROJECT | Provision of Group Housing at Ash Lane, Co. Sligo | |
| CLIENT / JOB NO | Sligo County Council | 7051 |
| DOCUMENT TITLE | Screening for Appropriate Assessment | |

Prepared by

Reviewed / Approved by

| Document | Name | Name |
|-------------|---------------------|----------------|
| FINAL | Dr. Monica Sullivan | Conor McCarthy |
| August 2023 | | |

This document, and information or advice which it contains, is provided by JENNINGS O'DONOVAN & PARTNERS LIMITED solely for internal use and reliance by its Client in performance of JENNINGS O'DONOVAN & PARTNERS LIMITED's duties and liabilities under its contract with the Client. Any advice, opinions, or recommendations within this document should be read and relied upon only in the context of the document as a whole. The advice and opinions in this document are based upon the information made available to JENNINGS O'DONOVAN & PARTNERS LIMITED at the date of this document and on current standards, codes, technology and construction practices as at the date of this document. Following final delivery of this document to the Client, JENNINGS O'DONOVAN & PARTNERS LIMITED will have no further obligations or duty to advise the Client on any matters, including development affecting the information or advice provided in this document. This document has been prepared by JENNINGS O'DONOVAN & PARTNERS LIMITED in their professional capacity as Consulting Engineers. The contents of the document does not, in any way, purport to include any manner of legal advice or opinion. This document is prepared in accordance with the terms and conditions of JENNINGS O'DONOVAN & PARTNERS LIMITED contract with the Client. Regard should be had to those terms and conditions when considering and/or placing any reliance on this document. Should the Client wish to release this document to a Third Party for that party's reliance, JENNINGS O'DONOVAN & PARTNERS LIMITED may, at its discretion, agree to such release provided that:

- (a) JENNINGS O'DONOVAN & PARTNERS LIMITED written agreement is obtained prior to such release, and
- (b) By release of the document to the Third Party, that Third Party does not acquire any rights, contractual or otherwise, whatsoever against JENNINGS O'DONOVAN & PARTNERS LIMITED and JENNINGS O'DONOVAN & PARTNERS LIMITED, accordingly, assume no duties, liabilities or obligations to that Third Party, and
- (c) JENNINGS O'DONOVAN & PARTNERS LIMITED accepts no responsibility for any loss or damage incurred by the Client or for any conflict of JENNINGS O'DONOVAN & PARTNERS LIMITED's interests arising out of the Client's release of this document to the Third Party.

Directors: D. Kiely, C. McCarthy

Regional Director: A. Phelan

Consultants: C. Birney, R. Gillan

Senior Associates: R. Davis, M. Forbes, S. Gilmartin, J. Healy, S. Lee, J. McElvaney, T. McGloin, S. Molloy

Associates: B. Coyle, D. Guilfoyle, L. McCormack, C. O'Reilly, M. Sullivan

Company Reg No. 149104 **VAT Reg. No.** IE6546504D



SLIGO COUNTY COUNCIL**GROUP HOUSING****AT ASH LANE****CO. SLIGO****SCREENING FOR APPROPRIATE ASSESSMENT****CONTENTS**

| | | |
|-----|--|----|
| 1 | INTRODUCTION | 1 |
| 1.1 | BACKGROUND | 1 |
| 1.2 | AUTHOR'S QUALIFICATION AND EXPERTISE | 1 |
| 1.3 | REGULATORY CONTEXT..... | 2 |
| 1.4 | THE STAGES IN AN APPROPRIATE ASSESSMENT | 4 |
| 1.5 | SCREENING METHODOLOGY | 4 |
| 1.6 | DESK STUDY | 5 |
| 1.7 | CONSULTATION..... | 5 |
| 1.8 | FIELD STUDY | 5 |
| 1.9 | FLOODING..... | 6 |
| 2 | PROJECT DESCRIPTION | 6 |
| 2.1 | SITE LOCATION..... | 6 |
| 2.2 | PROPOSED WORKS | 7 |
| 3 | RECEIVING ENVIRONMENT | 7 |
| 3.1 | GEOLOGY AND SOILS | 7 |
| 3.2 | HYDROLOGY AND HYDROGEOLOGY..... | 8 |
| 3.3 | HABITATS: | 10 |
| 3.4 | INVASIVE SPECIES | 12 |
| 4 | SCREENING FOR APPROPRIATE ASSESSMENT | 13 |
| 4.1 | EUROPEAN SITES WITHIN THE ZONE OF INFLUENCE (ZOI) OF THE PROJECT | 13 |
| 4.2 | IDENTIFICATION OF SOURCE PATHWAY RECEPTOR (SPR) MODEL PATHWAYS ... | 22 |
| 4.3 | IN-COMBINATION EFFECTS | 23 |
| 5 | SCREENING ASSESSMENT – CONCLUSION | 25 |
| 6 | RECOMMENDATIONS | 25 |
| 7 | REFERENCES | 25 |

APPENDIX I: Ground Investigation Report

APPENDIX II: Construction Methodology and Environmental Management Plan

1 INTRODUCTION

1.1 BACKGROUND

Jennings O'Donovan & Partners Limited have been commissioned by Sligo County Council to carry out a Stage I Appropriate Assessment Screening under Article 6(3) of Council Directive 92/43/EEC (Habitats Directive) for the Provision of Works for Group Housing at Ash Lane, Co. Sligo. This involves the conversion of part of the existing Glenview halting site for group housing use.

The original halting site scheme was developed in the 1990s, and over 30 years later, elements of the infrastructure need to be upgraded and renewed to meet Department requirements associated with a further 60 year life for housing scheme elements.

The Group Housing Scheme has been identified in Sligo County Council's Traveller Accommodation Programme 2019-2024 and in the Sligo County Council Housing Delivery Action Plan 2022-2026.

The proposed works involve the demolition of the existing halting bay service units and the construction of 3 No residential housing units (1 No detached and 2 No, semi-detached). It is also proposed to construct new boundary walls within the site to facilitate subdivision of the housing units. The proposed works also include upgrade works to an existing vehicular entrance and access road to the development site at the northwest of the site, off the N16, Ash Lane Road and upgrade works to the existing access road into the development and all associated site development and drainage works. The development will involve connection to the existing Irish Water Foul Sewer network with Storm water discharged, via a petrol interceptor, attenuation tank, and flow control hydro brake, to an existing Local Authority Storm Water pipe network. Existing boundary block walls will be retained within the proposed development. The redline boundary given on the drawings indicate the extents of site works for the proposed development. A full set of drawings are located in Appendix II.

The works hereafter in this report will be identified as 'the Project'.

The purpose of this report is to assess the various elements of the Project in terms of potential impacts to European Sites within the Zone of Influence (Zoi) of the Project. Potential cumulative impacts of the overall project, individually and in-combination with other plans and projects within the area of the waterbody catchment were also. Locations where works were carried out were surveyed for the presence of protected habitats and species as set out in the Birds and Habitats Directives.

This proposal is not necessary for the conservation management of a European Site.

1.2 AUTHOR'S QUALIFICATION AND EXPERTISE

This Stage I Appropriate Assessment Screening has been prepared by Dr. Monica Sullivan, Principal Environmental Scientist and Lead Ecologist at Jennings O'Donovan & Partners Limited. She is a full member of the Chartered Institute of Ecology and the Environmental Management and a chartered Environmentalist. Dr. Sullivan has over 36 years' experience in the natural sciences, specialising in

fisheries management, aquatic ecology and freshwater invertebrate taxonomy. She has lectured since the mid 1990's – 2017 in invertebrate zoology, ecology and environmental pollution control to both masters and degree students. She was the examiner for the freshwater biology module for the Institute of Fisheries Management, England. Monica's experience includes invasive species surveys, management plans, ecological studies, Environmental Impact Assessment (EIA) screenings, Appropriate Assessment (AA) screenings, Natura Impact Statements (NIS), otter surveys, badger surveys, freshwater macroinvertebrate and instream flora surveys.

Qualified to doctorate level, Monica previously worked as a partner in an environmental consultancy, undertaking fieldwork and specialising in Environmental Assessments of medium to large scale infrastructural projects and the coordination and management of AA and Environmental Impact Assessment processes. She has a clear understanding of the legislative framework governing the extent of environmental investigations, assessments and reports required to secure the necessary approvals on all types of projects. She has extensive experience in management of specialist sub-consultants and working in a team environment and a history of collaborating with participants on research projects. Dr. Sullivan was author and researcher on an Environmental Government Program on invasive species. She is chief author of a chapter in the book Zebra Mussels in Europe and has published many papers on the topic. She spent several years working as both English and Scientific editor for international scientific journals. In 2017, she was expert advisor for 'horizon scan' invasive species workshop.

1.3 REGULATORY CONTEXT

Under Section 177U (1) of the Planning Acts, a Screening for AA of the Project shall be carried out by the competent authority (in this case, Sligo County Council) to assess in view of best scientific knowledge, if the Project, individually or in combination with other plans or projects, is likely to have a significant effect(s) on any European Sites.

Collectively, Special Areas of Conservation (SACs) and Special Protection Areas (SPAs) are referred to as the Natura 2000 Sites. The legal basis on which SACs are selected and designated is the EU Habitats Directive, 92/43/EEC transposed into Irish law by the European Communities (Birds and Natural Habitats) Regulations 2011 (S.I. No. 477 of 2011), as amended. The designation features of SACs are referred to as Qualifying Interests (QI) and include both species (excluding birds) and habitats. Similarly, Special Protection Areas (SPA's) are legislated in the Birds Directive 2009/147/EC. The designation features of SPAs are referred to as Special Conservation Interests (SCIs) which comprise bird species as well as wetland bird habitats.

In general terms, SACs and SPAs are considered to be of exceptional importance in terms of rare, endangered or vulnerable habitats and species within the European Community.

Article 6, paragraph 3 of the Habitats Directive states that:

“Any plan or project not directly connected with or necessary to the management of the site but likely to have a significant effect thereon, either individually or in-combination with other plans or projects, shall be subject to appropriate assessment of its implications for the site in view of the site's conservation objectives. In the light of the conclusions of the assessment of the implications

for the site and subject to the provisions of paragraph 4, the competent national authorities shall agree to the plan or project only after having ascertained that it will not adversely affect the integrity of the site concerned and, if appropriate, after having obtained the opinion of the general public”.

The statutory agency responsible for the European Sites is the National Parks and Wildlife Service of the Department of Culture, Heritage and the Gaeltacht.

This report has been prepared in accordance with current guideline documents:

- Assessment of plans and projects significantly effecting Natura 2000 sites: Methodological guidance on the provisions of Article 6(3) and (4) of the Habitats Directive 92/43/EEC (EC, 2001)
- Appropriate Assessment of Plans and Projects in Ireland - Guidance for Planning Authorities (DEHLG 2009, Revised February 2010)
- Appropriate Assessment of Plans and Projects in Ireland Guidance for Planning Authorities. Department of the Environment, Heritage and Local Government (DoEHLG, 2009, revised 2010)
- OPR Practice Note PN01: Appropriate Assessment Screening for Development Management, March 2021, Office of the Planning Regulator
- Communication from the Commission on the Precautionary Principle. Office for Official Publications of the European Communities, Luxembourg, (EC, 2000a)
- European Communities (Birds and Natural Habitats) Regulations, 2011 (S.I. No.477 of 2011).
- Interpretation Manual of European Union Habitats. Version EUR 28. European Commission (EC, 2013).
- EU Guidance document on Article 6(4) of the 'Habitats Directive' 92/43/EEC (EC, 2007)
- Managing Natura 2000 Sites: The provisions of Article 6 of the 'Habitats' Directive 92/43/EEC (EC, 2018)
- Strict Protection of Animal Species, NPWS, 2021

The following European Court and Irish High Court rulings have been considered:

- C-127/02 Waddenzee v Staatssecretaris
- C-258/11 Sweetman v An Bord Pleanála
- C-512/12 Briels
- C-387/12 & C388/15 Orleans and others v Vlaams Gewest
- C-142/15 Moorbug
- C-323/17 People Over Wind and Peter Sweetman v Coillte
- C-162/17 Grace and Sweetman
- C-883/18 Holohan and others v An Bord Pleanála
- IEHC 84 (2019) - Kelly v An Bord Pleanála

Relevant plans from national to local scales are critical to inform a robust assessment of in-combination impacts; these are listed below:

- National Biodiversity Action Plan, for the period 2017-2021
- River Basin Management Plan for Ireland 2018-2021
- Sligo County Development Plan 2017-2023 (Under Review) (Proposal to extend to July 2024)

- Sligo County Development Plan 2023-2029 (Pre-Draft Public Consultation)

1.4 THE STAGES IN AN APPROPRIATE ASSESSMENT

There are 4 stages in an Appropriate Assessment as outlined in the European Commission Guidance document (2001). The following is a brief summary of these steps:

Stage 1 – Screening: This stage examines the likely effects of a project either alone or in-combination with other projects upon a European Site and considers whether it can be objectively concluded that these effects will not be significant.

Stage 2 – Appropriate Assessment: In this stage, the impact of the project on the integrity of the European Site is considered, with respect to the conservation objectives of the site and to its structure and function.

Stage 3 – Assessment of Alternative Solutions: Should the Appropriate Assessment determine that adverse impacts are likely upon the European Site, this stage examines alternative ways of implementing the project that, where possible, avoid these adverse impacts.

Stage 4 – Assessment where no alternative solutions exist and where adverse impacts remain: Where imperative reasons of overriding public interest (IROPI) exist, an assessment to consider whether compensatory measures will or will not effectively offset the damage to the European Site will be necessary.

As part of this Screening for Appropriate Assessment, a desk-based study of the European Site within the Zol of the Project is required.

1.5 SCREENING METHODOLOGY

The function of the Screening Assessment is to identify whether or not the project will have a likely significant effect on any European Site. In this context “likely” refers to the presence of doubt with regard to the absence of significant effects (ECJ case C-127/02) and “significant” means not trivial or inconsequential but an effect that has the potential to undermine the site’s conservation objectives (ECJ case C-127/02). In other words, any effect that compromises the functioning and viability of a site and interferes with achieving the conservation objectives for the site would constitute a significant effect.

The nature of the likely interactions between the Project and the integrity of a European Site will depend upon the sensitivity of the European Site’s qualifying features to potential impacts arising from the Project; the current conservation status of the European Site and its qualifying features; and any likely changes to key environmental indicators (e.g. water quality) that underpin the conservation status of European Sites and their qualifying features, in-combination with other plans and projects.

The European Commission (2018) Guidelines outline the stages involved in undertaking a Screening Assessment of a project that has the potential to have likely significant effects on European Sites. The methodology adopted for this Screening Assessment is informed by these guidelines and was undertaken in the following steps:

1. Define the project and determine whether it is directly connected with or necessary for the conservation management of European Sites
2. Identify other plans or projects that, in-combination with the project, have the potential to effect European Sites
3. Assess whether or not the project is likely to have significant effects on European Sites in the view of its conservation objectives.

1.6 DESK STUDY

A desk study was carried out to collate the available information on the ecological environment of the Project area. The National Parks and Wildlife Service (NPWS) database was consulted concerning designated conservation areas and records of rare and protected plant and animal species in the vicinity of the Project. The National Biodiversity Data Centre (NBDC) website was also consulted. One kilometre Grid square 'G6936' incorporates the entire Project with twenty one protected species recorded including Common Frog (*Rana temporaria*), Black-headed Gull (*Larus ridibundus*), Common Kingfisher (*Alcedo atthis*), Common Redshank (*Tringa totanus*), Common Starling (*Sturnus vulgaris*), Common Wood Pigeon (*Columba palumbus*), Eurasian Curlew (*Numenius arquata*), Eurasian Oystercatcher (*Haematopus ostralegus*), Great Cormorant (*Phalacrocorax carbo*), Herring Gull (*Larus argentatus*), House Sparrow (*Passer domesticus*), Mallard (*Anas platyrhynchos*), Little Egret (*Egretta garzetta*), Mew Gull (*Larus canus*), Mute Swan (*Cygnus olor*), Northern Lapwing (*Vanellus vanellus*), Sand Martin (*Riparia riparia*), Eurasian Badger (*Meles meles*), Eurasian Pygmy Shrew (*Sorex minutus*), European Otter (*Lutra lutra*), West European Hedgehog (*Erinaceus europaeus*).

The Sligo County Development Plan 2017-2023 (proposal to extend to July 2024), the Sligo County Development Plan 2023 – 2029 (Pre-Draft Public Consultation) and the Sligo County Council planning enquiry website were reviewed to identify any proposed plans or projects which may have a direct, indirect or cumulative impact with the Project.

1.7 CONSULTATION

Sligo County Council engineers were consulted in relation to Ground Investigations (GI). The GI report was reviewed and is included in Appendix I. Recommendations outlined during a site visit in May by field ecologist, Dr. Sullivan have been incorporated into the Construction Methodology and Environmental Management Plan (Appendix II). Sligo County Council issued a letter of notification regarding this development to NPWS on June 7th, 2023, Reference No. 1.18.18.

1.8 FIELD STUDY

A site visit was carried out on May 24, 2023 on a cloudy dry day with an ambient temperature of 10degrees Celsius. The survey consisted of traversing the entire Project site being conscious of adjacent lots and any invasive species either overhanging the Project or rooted near/within the site. Habitat classification followed Fossitt (2000) and the floral nomenclature used followed Parnell and Curtis (2012) and Scannell and Synnott (1987). The locations where works will be carried out were also surveyed for the presence of invasive species (as listed in the Third Schedule of S.I. No. 477 of 2011, EC (Birds and Natural Habitats) Regulations 2011).

1.9 FLOODING

Office of Public Works (OPW) website and the CFRAM study were accessed (May, 2023) to determine flood areas within and near the Project. Unfortunately, current update available information for Sligo town is under review. However, information is available that shows the probability of flooding at and in the vicinity of the Project, along with records of past flood events.

The Project itself has no surface or groundwater records of flooding events (including winter 2015/2016 Geological Survey Ireland surface water flooding records). The Project itself has no coastal or fluvial flood events. The nearest historical previous flood event occurred north of Ash Lane in the property grounds of the Sligo Atlantic Unit, approximately 34 metres northeast of the Project. Due to the elevated aspect of the site there have been no historic flood events and there is no foreseen risk of a flood event extending to the Project in the future.

The Geological Survey Ireland (GSI) Groundwater Flooding Probability Maps were also examined (May, 2023) to determine if there was an existing risk from groundwater flooding at the site. The groundwater flood mapping confirmed that the site is not at risk from groundwater flooding with the closest historic record of groundwater flooding to the Project also approximately 34 metres northeast of the Project. Given that the entirety of bedrock at the work area is of 'Glencar Limestone Formation', there is not a high risk of groundwater flooding.

The associated ground waterbody (GWB) Drumcliff-Strandhill (EPA Code IE_WE_G_0044) is Poorly productive bedrock" and covers an overall area of approximately 96km². The Water Framework Directive (WFD) latest status for this GWB is 'Not at risk'. The 2016-2021 overall groundwater status is 'Good', indicating no change from the previous monitoring periods 2013-2018, 2010-2015 and 2007-2012 status.

2 PROJECT DESCRIPTION

2.1 SITE LOCATION

The Project is located on Ash Lane off the main N16 road. It is located within Sligo town with the Atlantic Technological University to the north, Stephen Mc Donagh Place to the west, Sligo General Hospital to the east and Greenfort Park to the south (Figure 2.1). The site location map is also attached in Appendix II, Drawing: 1.18.18 - SCC - 00 - ZZ - DR - A - 2001



Figure 2.1: General location of the Project

2.2 PROPOSED WORKS

A Construction Methodology and EMP has been developed for the Site works and is attached as Appendix II.

In brief, overall works will include the demolition of the existing halting bay service units and the construction of 3 No residential housing units (1 No detached and 2 No. semidetached) (Drawing No. S603-OCSC-XX-XX-DR-C-0605). It is also proposed to construct new boundary walls within the site to facilitate subdivision of the housing units. The proposed works also include upgrade works to an existing vehicular entrance and access road to the development site at the northwest of the site (Drawing No. S603-OCSC-XX-XX-DR-C-0610), off the N16, Ash Lane Road and upgrade works to the existing access road into the development and all associated site development and drainage works (Drawing No. S603-OCSC-XX-XX-DR-C-0620). The development will involve connection to the existing Irish Water Foul Sewer network with Stormwater discharged, via a petrol interceptor, Attenuation Tank, and flow control hydro brake, to an existing Local Authority Storm Water pipe network. Existing boundary block walls are to be retained within the proposed development (Drawing No. S603-OCSC-XX-XX-DR-C-0160). The redline boundary given on the drawings indicate the extents of site works for the proposed development.

3 RECEIVING ENVIRONMENT

3.1 GEOLOGY AND SOILS

The quaternary sediments at the site of the Project are classified as 'till derived from Namurian sandstones and shales'.

The Project is located within the Glencar Limestone Formation. This bedrock formation is described by the Geological Survey of Ireland as 'dark fine limestone & calcareous shale'. Corine 2018 denote this area as *artificial non-agricultural vegetated areas*.

3.2 HYDROLOGY AND HYDROGEOLOGY

The site overlies bedrock which is classified as a '*Locally Important Aquifer – Bedrock which is Moderately Productive only in Local Zones*.' The groundwater vulnerability at the site is classified as 'Moderate to High'.



Figure 3.1: WFD River Sub Basin (RSB) and orthographic view of surrounding landscape

The Project is wholly located within the Garavogue_010 WFD River Sub Basin (RSB) covering an area of approximately 106km² (Figure 3.1). The RSB had 'Poor' ecological status for the 2016-2021 period.

The order 2 Sligo Stream (Segment Code: 35_3792) lies approximately 56 metres north of the Project (Figure 3.2) and the N16 road. The Sligo Stream flows in a westerly direction for approximately 570 metres and discharges into the Garavogue Estuary and subsequently the Atlantic Ocean.

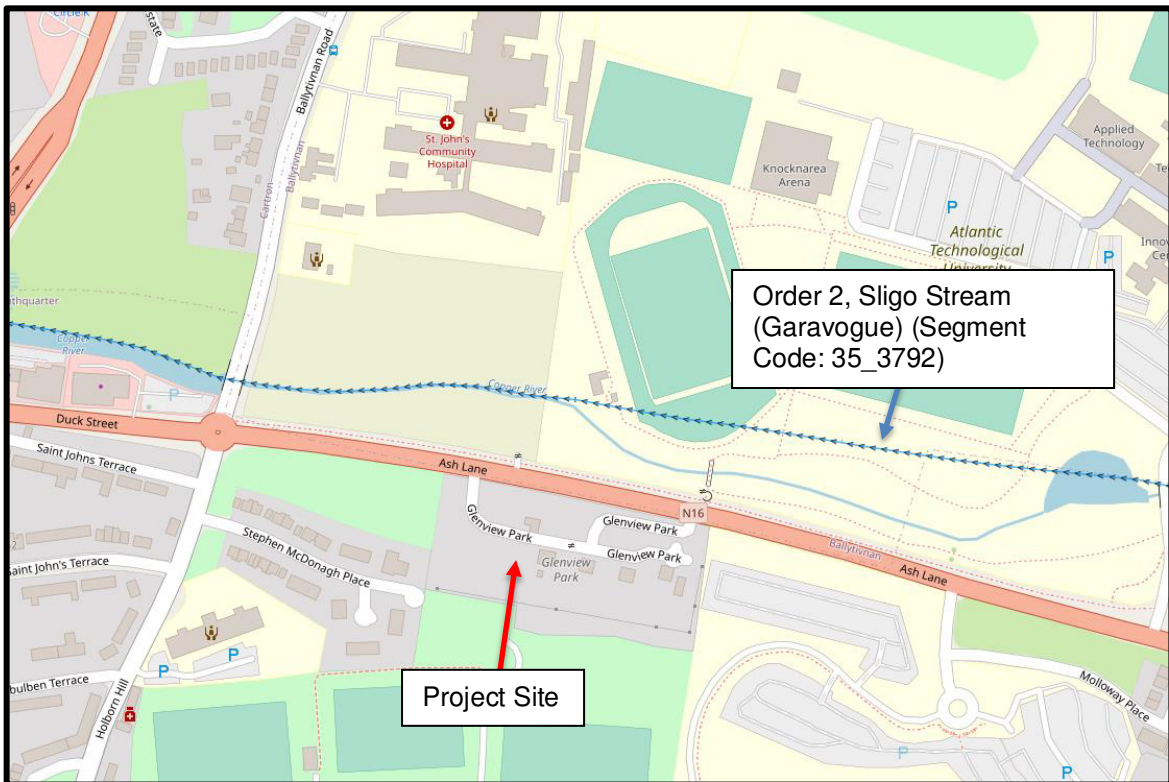

Figure 3.2: Watercourses and waterbodies in the vicinity of the Project

Currently, the groundwater in the area has no significant underlying pressures, including waste abstraction, agriculture, anthropogenic, aquaculture, atmospheric, extractive industry, hydro morphology, invasive species, urban runoff or otherwise (EPA Water Maps, accessed May 25th, 2023). The Project is however within a groundwater area denoted as SAC habitat sensitive SAC species sensitive and SPA Habitats sensitive (EPA Maps website, accessed May 2023). The Project is also within the Carrowmore East groundwater body for the abstraction of drinking water (Article 7- EPA code IEPA1_WE_G_0042).

The EPA Maps (Water) website was also accessed (May 2023) to examine the Project area and its environs for nitrate and phosphorus loading and Pollutant Impact Potential (PIP). PIP maps for Nitrogen (N) and Phosphorus (P) have been generated by the EPA to show the highest risk areas in the landscape for losses of N and P to waters. The PIP model estimates the annual nutrient losses from agricultural land at specific locations, using spatial data from farm management, soils and hydrogeology. This model estimates loads at an annual temporal resolution.

The area immediately surrounding the Project encompasses Sligo town and more locally, an area where educational, medical and residential use prevails. The wider surrounding landscape is largely comprised of the Sligo urban landscape with Ash Lane to the north, residential estates to the west, urban amenities to the south, while the east has the carpark of Sligo General Hospital.

The land associated with the Project has been highly modified in the past; it was landscaped to provide residential dwellings and is now a mix of both a brownfield and greenfield site.. The Project and

immediate surrounding lands do not have a Phosphorus ranking. The wider area has phosphorus rankings between 2, 4, 6 and 7 (7 being the lowest impact ranking). Pollution Impact Potential Nitrate (PIP N) for the lands within and surrounding the Project also do not have a ranking. The Site is on a north facing, relatively steep slope (3,500 north rising to 8,500 at the northwest tip). There is a steep vegetated embankment rising directly from southern boundary of the site reaching up to over 18,000 (Drawing Site Layout,). The lack of an overall ranking for these parameters likely reflects little fertiliser use on the Project land in the past, with low-level or no stock. Overall, the Critical Source Areas Maps for the Project and adjacent lands do not indicate a Site where either phosphorus or nitrates are a significant issue.

As noted earlier in Section 3.2, the Project is within the WFD River Sub Basin Garavogue_010. Currently, there are no significant nitrogen or phosphorus pressures from the Project site on this RSB.

3.3 HABITATS:

A site visit was carried out on May 24, 2023 on a cloudy dry day with an ambient temperature of 10degrees Celsius. The survey area consisted of a stretch of approximately 52.5m along the entire northern boundary along Ash Lane N16 roadway and extending back approximately 50m southward to the most southerly boundary wall of the existing settlement (Drawings: Site Location, Appendix II). An area outside of the current southern boundary wall was also surveyed as this area will be included in this application to accommodate a horsebox/stable (Drawings: Site Layout, Appendix II). All Drawings for the proposed works are allocated in Appendix II.

Six habitats (according to Fossitt, 2000) were noted within the survey area, namely WL1: Hedgerow/WL2: Treeline, BL3: Artificial Surfaces, ED3: Recolonising bare ground, GA1: Improved Agricultural Grassland and GS4: Wet grassland (Figure 3.3).



Figure 3.3. Some of the primary habitats onsite

No Annex I habitat occurs within the area of proposed works.

No rare, threatened, or protected species of plants as per the Red Data Book (Curtis and McGough, 1988) were found. No species listed in the Flora Protection Order (2022) were found to be growing within the proposed site of works.

WL1/WL2: Hedgerow/Treeline

This is a conspicuous habitat type along the majority of the northern margin of the proposed development with the exception of a road access break. The hedgerow/treeline delineates the northern boundary of the site. It is variable in structure, but generally dense and continuous and is largely unmanaged (particularly on the northern internal site aspect; some pruning has occurred externally along the footpath and the N16 road). Branches from different species are overreaching and intertwining with one another. Maximum height in this linear hedgerow is accomplished by a non-native sycamore (*Acer pseudoplatanus*) growing to approx 8-10m tall. Hawthorn (*Crataegus monogyna*) and elder (*Sambucus nigra*) are generally lower in height (approx 4-5m tall). The hedgerow along the northwestern footpath supports a semi-mature ash tree which is also approx. 8m tall. Unfortunately, it is apparent that this ash tree specimen has contracted the die-back fungal disease (*Hymenoscyphus fraxineus*) and is in the early stages of a declining state of health. The understorey of the WL1/WL2 habitat merges with adjacent grassy margin habitat; it is also creeping out onto the footpath. Most notable undergrowth flora includes ivy (*Hedera hibernica*) and bramble (*Rubus fruticosus* agg.).

A dense linear continuous hedgerow (generally approx. 2-3m tall) has been planted along the northwestern internal road. It is overgrown and unmanaged. There are several cultivars in the mixture with some native species such as elder (*Sambucus nigra*), willow (*Salix* spp.), ash (*Fraxinus excelsior*), blackthorn (*Prunus spinosa*) and hawthorn (*Crataegus monogyna*). Understorey includes common figwort (*Scrophularia nodosa*), ivy (*Hedera hibernica*), willowherb (*Epilobium* spp.), pignut (*Conopodium majus*) and herb Robert (*Geranium robertianum*). *Galium aparine* cleaver and bramble (*Rubus fruticosus* agg.) are both utilising the hedgerow structure to spread.

BL3: Artificial Surfaces

The houses, roads (largely tarmac), yards and pathways onsite all come under this category of artificial manmade surfaces. There are also several walls bordering different aspects of the site that are finished in pebbledash with cement capping, reach up to 3.5m tall and are devoid of vegetation. Similarly, there are also two pillars near the site entrance off the N16 that are approx 1m tall, with a stone and cement facing, cement capping, also devoid of floral growth. The northwestern entrance along the footpath has a cement post and rail fencing approx 1.25m tall that is heavily vegetated with overhanging and climbing ivy (*Hedera hibernica*).

ED3: Recolonising Bare Ground

There are limited areas (approx. 10m²) where gravel has been laid as an artificial surface onsite but is increasingly becoming colonised by encroaching vegetation from nearby grassland. Much of these areas are currently dominated by grasses and dandelions (*Taraxacum* spp.). Both ribwort plantain (*Plantago lanceolata*) and broadleaf plantain (*Plantago major*) are present and broad-leaved dock

(*Rumex obtusifolius*), daisies (*Bellis perennis*) and black medick (*Medicago lupulina*) have also secured a foothold in this habitat.

GA1: Improved Agricultural Grassland

Grassland habitat dominates the greenfield aspect of the site and is located due west and north of the proposed dwellings. Underlying soils are shales and sandstones till (Namurian). Much of the grassland is tightly grazed by a horse. This habitat has been modified in the past with grasses now dominating the vegetative composition. Yorkshire-fog (*Holcus lanatus*) and false oat grass (*Arrhenatherum elatius*) are common. Other herbaceous vegetation include rosebay willowherb (*Epilobium angustifolium*), broad-leaved and narrow-leaved dock (*Rumex obtusifolius* and *R. acetosa* respectively), ribwort plantain (*Plantago lanceolata*), clovers (*Trifolium* spp.), daisy (*Bellis perennis*), dandelion (*Taraxacum* sp.) and both buttercup species (*Ranunculus repens* and *R. acris*), nettle (*Urtica dioica*), common chickweed (*Stellaria media*) with lesser celandine (*Ficaria verna*) and common figwort (*Scrophularia nodosa*) near the northern hedgerow treeline northern margin. A few cuckoo flowers (*Cardamine pratensis*) are also present and in wetter areas of the grassland.

GS4: Wet grassland

This grassland type is located west of the access road into the site and also south of the current boundary wall on steeply sloping ground. The grassland is tightly grazed by horses leaving conspicuous stands of yellow iris (*Iris pseudacorus*) amongst bare ground terracing.

The grassland proximate to the southern boundary wall (approx. 10m²) has a more concentrated mix of typical ruderal colonisers such as broad-leaved dock (*Rumex obtusifolius*), ribwort plantain (*Plantago lanceolata*), clovers (*Trifolium repens*), daisy (*Bellis perennis*), dandelion (*Taraxacum* sp.), both buttercup species (*Ranunculus repens* and *R. acris*), marsh thistle (*Cirsium dissectum*), hedge mustard (*Sisymbrium officinale*), ragwort (*Jacobea vulgaris*), lesser celandine (*Ficaria verna*) and glaucous sedge (*Carex flacca*) amongst others. Colt's foot (*Tussilago farfara*) is present near the entrance to this grassland from the footpath. The western site margin is outlined by a wooden fence post in disrepair with barbed wire.

No suitable habitat (devil's bit scabious – *Succisa pratensis*) was detected for the marsh fritillary (*Euphydryas aurinia*) butterfly during the site walkover.

3.4 INVASIVE SPECIES

No invasive alien species as listed on the Third Schedule of the European Communities (Birds and Natural Habitats) Regulations, 2011 (S.I. No. 477 of 2011) Part 1 or 2 or species of Union Concern were recorded within the Project or its close environs (incorporating 7m in all directions, to allow for any Japanese knotweed root system).

4 SCREENING FOR APPROPRIATE ASSESSMENT

This AA Screening examined the likely significant effects of the Project, either alone or in-combination with other projects or plans on European Sites, that were situated within a Zol, or a distance that has a potential source-pathway-receptor (SPR), both direct and indirect with the Project.

A total of twelve European Sites (7 SACs and 5 SPAs) occur within a wider 15km radius of the Project and are listed in Table 4.1.

Table 4.1: European Sites within a 15km radius

| No. | European Sites within 15km radius | Terrestrial Distance between the Project and European Site | Hydrologically Linked to the Project (Yes/No) |
|-----|---|--|---|
| | SAC | | |
| 1 | Cummeen Strand/Drumcliff Bay (Sligo Bay) SAC (000627) | 0.4km | Yes |
| 2 | Lough Gill SAC (001976) | 0.5km | Yes (upstream) |
| 3 | Ballysadare Bay SAC (000622) | 6.5km | Yes |
| 4 | Benbulbin, Gleniff and Glenade Complex SAC (000623) | 6.7km | No |
| 5 | Union Wood SAC (000638) | 7.2km | No |
| 6 | Unshin River SAC (001898) | 7.5km | No |
| 7 | Streedagh Point Dunes SAC (001680) | 13.7km | Yes |
| | SPA | | |
| 1 | Cummeen Strand SPA (004035) | 0.4km | Yes |
| 2 | Drumcliff Bay SPA (004013) | 5.0km | Yes |
| 3 | Sligo/Leitrim Uplands SPA (004187) | 5.1km | No |
| 4 | Ballysadare Bay SPA (004129) | 6.5km | Yes |
| 5 | Ballintemple and Ballygilgan SPA (004234) | 8.3km | No |

4.1 EUROPEAN SITES WITHIN THE ZONE OF INFLUENCE (ZOI) OF THE PROJECT

The European Sites identified as being within the Project Zone of Influence (Zol) using the Source Pathway Receptor (SPR) principle, will be assessed to examine the likelihood of significant effects of the Project either alone or in-combination with other plans or projects, on any European Sites.

The Environmental Protection Agency (EPA) maps were used to identify European Sites that could potentially be located within the Zol and possibly be connected to the Project site via pathways. In this instance, given the size and scale of the Project, the short-term temporary nature of the works, works will be contained within the Project site, a terrestrial distance of 500m from the Project has been identified as the Zol for any European Site. Other European Sites with a hydrological link either upstream or downstream are considered to have a potential wider Zol and are assessed separately in Section 4.2.

While five European Sites are located within a terrestrial distance range of 15km range, only three fall within the 500m Zol of the Project and include Cummeen Strand/Drumcliff Bay (Sligo Bay) SAC (000627) (located approximately 432m west), Cummeen Strand SPA (004035) (located approximately 445m west) and Lough Gill SAC (001976) (located approximately 529m south) (Figures 4.1 and 4.2 respectively). All three European sites are also noted to be within an area where the groundwater is sensitive to SAC habitat and species and SPA habitats.

The next nearest European Site to the Project is Drumcliff Bay SPA (004013) located over 5km terrestrial distance northeast and greater than 10km hydrological distance (including intermediate dilution of Sligo Bay) from the Project. Drumcliff Bay is the most northerly of Sligo Bay's three estuarine inlets and is located further north along the coastline from the discharge of the Sligo stream into Sligo Bay. It comprises an inner area of sheltered estuarine habitat and an outer area of shallow seawater. The SPA extends 9 km east to west from Drumcliff village to Raghly Point. Drumcliff Bay is the estuary of the Drumcliff River, a substantial river flowing from Glencar Lough to the east. The site is a Special Protection Area (SPA) under the E.U. Birds Directive of special conservation interest for sanderling (*Calidris alba*) and bar-tailed Godwit (*Limosa lapponica*). Both sanderling and bar-tailed Godwit feed along the tidal edge, on a diet predominantly comprised of polychaete worms and invertebrates. The E.U. Birds Directive pays particular attention to wetlands and, as these form part of this SPA, the site and its associated waterbirds are of special conservation interest for Wetland & Waterbirds. Since there is a terrestrial distance of 5km (or more) from the Project, visual and noise disturbance on any birds utilising the SPA wetlands are not considered likely. Similarly, significant effects are not considered likely on the foraging grounds of these birds as a result of the hydrological link which includes the dilution of Sligo Bay waters. This European Site was therefore not considered to be within the Zol. Ballintemple and Ballygilgan SPA (Code 004234) is located approx. 8.3km northwest of the Project and comprises two separate areas of fields supporting agriculturally improved grassland, situated on the north side of Drumcliff Bay, Co. Sligo. This site was also not considered to be within the Zol of the Project.

In relation to mobile species listed as qualifying features of European Sites, the following guidance was used to identify whether it recommends the European Site is located within the Zol of the Project:

- SPAs with mobile bird species: "Assessing connectivity with Special Protection Areas (SPAs)" (2016) guidance document was used to identify connectivity between the Project site and SPAs in the wider surrounding area (SNH, now Natural Scotland) as applicable.
- SACs with bats as a qualifying feature were included when the Project occurred within the core sustenance zone of the qualifying bat population. No SACs occurred within a 5km radius designated for this qualifying feature.
- SACs with marsh fritillary as a qualifying feature are included where suitable marsh fritillary habitat occurs within the Project site footprint and where the Project site is located within a 10km radius of a marsh fritillary population. No suitable habitat (Devil's bit scabious) was detected during the multi-disciplinary site walkover. It is also noted that no SACs occurred within a 10km radius designation for this qualifying feature.

Nonetheless, further investigation of a SPR is assessed in Section 4.2 to confidently determine if there will be any potential effect on any European Site hydrologically linked during the construction or operation of this Project.

European Sites with a hydrological link will be assessed in Section 4.2.

Table 4.2: Relevant European Sites and reason for designation and data for Screening

| Designated Site | Reasons for designation (information correct as of 12 th May 2021) (*denotes a priority habitat) | Distance from Proposed Development (km) | Potential adverse effect: Source-Pathway-Receptor Linkage |
|--|--|---|---|
| SPECIAL AREAS OF CONSERVATION (SACs) | | | |
| Cummeen Strand/ Drumcliff Bay (Sligo Bay) SAC (000627) | <p>Species</p> <p><i>Vertigo angustior</i> (Narrow-mouthed Whorl Snail) [1014]</p> <p><i>Petromyzon marinus</i> (Sea Lamprey) [1095]</p> <p><i>Lampetra fluviatilis</i> (River Lamprey) [1099]</p> <p><i>Phoca vitulina</i> (Harbour Seal) [1365]</p> <p>Habitats</p> <p>Estuaries [1130]</p> <p>Mudflats and sandflats not covered by seawater at low tide [1140]</p> <p>Petrifying springs with tufa formation (Cratoneurion) [7220]</p> <p>Embryonic shifting dunes [2110]</p> <p>Shifting dunes along the shoreline with <i>Ammophila arenaria</i> (white dunes) [2120]</p> <p>Fixed coastal dunes with herbaceous</p> | The project site occurs at a distance of approx. 0.4km west of the project site | <p>This SAC is designated for its role in supporting three water dependent species, three water dependent habitats, five terrestrial based habitats and one sand-dune related species. There is no possibility for significant effects on these twelve QIs due to:</p> <ul style="list-style-type: none"> all works will be carried out according to the Construction Methodology and EMP (Appendix II) all chemicals and hydrocarbons will be located in the designated bunded area storm drainage will be designed in accordance with the Greater Dublin Strategic Drainage Study (GDSDS) and incorporates normal sustainable drainage systems (SuDS) measures before discharging to the existing Uisce Éireann storm water network installation of Modular Attenuation Units wrapped in a non-impermeable membrane and will include granular bedding, clause 505 and distribution pipe(s) Drawing S603 OCSC XX XX DR C 0620, Appendix II. the development will involve connection to the existing Irish Water Foul Sewer network with storm water discharged via a petrol interceptor, attenuation tank, and flow control hydro brake, to the existing Local Authority Storm Water pipe network if ground water is encountered during excavations, the water will be pumped from the excavation and discharged through a pumped main into the filtration bed |

| Designated Site | Reasons for designation (information correct as of 12 th May 2021) (*denotes a priority habitat) | Distance from Proposed Development (km) | Potential adverse effect: Source-Pathway-Receptor Linkage |
|-------------------------|--|---|--|
| | <p>vegetation (grey dunes) [2130]</p> <p><i>Juniperus communis</i> formations on heaths or calcareous grasslands [5130]</p> <p>Semi-natural dry grasslands and scrubland facies on calcareous substrates (Festuco-Brometalia) (* important orchid sites) [6210]</p> <p>According to this SAC's site Conservation Objectives document (Version 1. Department of Housing, Local Government and Heritage, 2013), for the listed QI, the Conservation Objective is to maintain the favourable conservation condition of the Annex I habitats and Annex II species for which the SAC has been selected.</p> | | <ul style="list-style-type: none"> no washing of any plant used in concrete transport will be allowed on site. all foundation bases are to be free of any standing water prior to concrete pours with provision of plastic (or similar) covering material to be on standby in the event of sudden rainfall planned concrete pours are to be coordinated with weather forecasting dune QI systems [2110], [2120], [5130] and [6210] are all located over 7km west of the Project (Map 6, NPWS 2013); direct and indirect effects are not anticipated as a result of these works during demolition, construction or operation <i>Vertigo angustior</i> [1017] are located over 8km west of the Project (Map 7, NPWS 2013); direct and indirect effects are not anticipated as a result of these works during demolition, construction or operation the stone engineering fill, linear drain, lined stone filtration bed and silt trap manhole will provide the collection, reduction in flow velocities and filter out sedimentation / pollutant's removal during the construction phase of the works. works will not occur within the SAC, so direct impacts are not anticipated on any QI. all works will be contained within the Project site. standard working procedures includes spill kits will be onsite at all times with suitably qualified trained personnel the size and scale of the Project works within a Project area of 0.45 hectares. works are temporary, short-term and localised; significant effects are not anticipated. works will be undertaken under the guidance of an Ecological Clerk of Works. |
| Lough Gill SAC (001976) | <p>Species</p> <p><i>Austropotamobius pallipes</i> (White-clawed Crayfish) [1092]</p> | The project site occurs at a distance of 0.5km south of the project site. | This SAC is designated for its role in supporting six water dependent species, two water dependent habitats and two terrestrial based habitats. There is no |

| Designated Site | Reasons for designation (information correct as of 12 th May 2021) (*denotes a priority habitat) | Distance from Proposed Development (km) | Potential adverse effect: Source-Pathway-Receptor Linkage |
|-----------------|--|---|--|
| | <p><i>Petromyzon marinus</i> (Sea Lamprey) [1095]</p> <p><i>Lampetra planeri</i> (Brook Lamprey) [1096]</p> <p><i>Lampetra fluviatilis</i> (River Lamprey) [1099]</p> <p><i>Salmo salar</i> (Salmon) [1106]</p> <p><i>Lutra lutra</i> (Otter) [1355]</p> <p>Habitats</p> <p>Natural eutrophic lakes with Magnopotamion or Hydrocharition - type vegetation [3150]</p> <p>Semi-natural dry grasslands and scrubland facies on calcareous substrates (Festuco-Brometalia) (* important orchid sites) [6210]</p> <p>Old sessile oak woods with <i>Ilex</i> and <i>Blechnum</i> in the British Isles [91A0]</p> <p>Alluvial forests with <i>Alnus glutinosa</i> and <i>Fraxinus excelsior</i> (Alno-Padion, <i>Alnion incanae</i>, <i>Salicion albae</i>) [91E0]</p> <p>According to this SAC's site Conservation Objectives document</p> | | <p>possibility for significant effects on these eleven QIs due to:</p> <ul style="list-style-type: none"> • all works will be carried out according to the Construction Methodology and EMP (Appendix II) • all chemicals and hydrocarbons will be located in the designated bunded area • storm drainage will be designed in accordance with the Greater Dublin Strategic Drainage Study (GDSDS) and incorporates normal sustainable drainage systems (SuDS) measures before discharging to the existing Uisce Éireann storm water network • installation of Modular Attenuation Units wrapped in a non-impermeable membrane and will including granular bedding, clause 505 and distribution pipe(s) Drawing S603 OCSC XX XX DR C 0620, Appendix II. • the development will involve connection to the existing Irish Water Foul Sewer network with storm water discharged via a petrol interceptor, attenuation tank, and flow control hydro brake, to the existing Local Authority Storm Water pipe network • if ground water is encountered during excavations, the water will be pumped from the excavation and discharged through a pumped main into the filtration bed • no washing of any plant used in concrete transport will be allowed on site. • semi-natural dry grasslands are located over 5.8km east of the Project and north of Lough Gill (Map 4, NPWS 2021); direct and indirect effects are not anticipated as a result of these works during demolition, construction or operation • old sessile oak woodlands [91A0] are located over 8km southeast on Killery mountain (Map 5, NPWS 2021); direct and indirect effects are not anticipated as a result of these works during demolition, construction or operation • alluvial forests [91E0] are located over 1km southeast on the northwestern shores of Lough Gill (Map 5, NPWS 2021); direct and indirect effects are |

| Designated Site | Reasons for designation (information correct as of 12 th May 2021) (*denotes a priority habitat) | Distance from Proposed Development (km) | Potential adverse effect: Source-Pathway-Receptor Linkage |
|--|---|--|--|
| | <p>(Version 1. Department of Housing, Local Government and Heritage, 2021), for the listed QI, the Conservation Objective is to maintain the favourable conservation condition of the Annex I Habitats and Annex II species for which the SAC has been selected.</p> | | <p>not anticipated as a result of these works during demolition, construction or operation</p> <ul style="list-style-type: none"> works will not occur within the SAC, so direct impacts are not anticipated on any QI. all works will be contained within the Project site. standard working procedures includes spill kits will be onsite at all times with suitably qualified trained personnel the size and scale of the Project works within a Project area of 0.45 hectares. works are temporary, short-term and localised; significant effects are not anticipated. works will be undertaken under the guidance of an Ecological Clerk of Works. works are temporary, short-term and localised; significant effects are not anticipated. works will be undertaken under the guidance of an Ecological Clerk of Works |
| SPECIAL PROTECTION AREAS (SPAs) | | | |
| <p>Cummeen Strand SPA (004035)</p> | <p>Species Light-bellied Brent Goose (<i>Branta bernicla hrota</i>) [A046] Oystercatcher (<i>Haematopus ostralegus</i>) [A130] Redshank (<i>Tringa totanus</i>) [A162] Wetland and Waterbirds [A999] According to this SPA's site Conservation Objectives document (Version 1. Department of Housing, Local Government and Heritage, 2013), for the listed QI, the Conservation Objective is to</p> | <p>The project site occurs at a distance of approx. 0.4km west of the project site</p> | <p>This SPA is designated for its role in supporting three water dependent species and one water dependent habitat. There is no possibility for significant effects on these four QIs due to:</p> <ul style="list-style-type: none"> no works will occur within the SPA, so direct impacts are not anticipated on any wetland associated with the foraging or roosting sites of the birds associated with this SPA the SPA is approx. 0.4km west of the Project (Map 1, NPWS 2013); due to the intervening urban landscape, there is no potential visual or noise disturbance on the birds associated with this SPA a potential SPR to the QI of this SAC exists via existing storm water pipe network discharging into the Sligo stream; however all works will be carried out according to the Construction Methodology and EMP (Appendix II) all chemicals and hydrocarbons will be located in the designated bunded area |

| Designated Site | Reasons for designation (information correct as of 12 th May 2021) (*denotes a priority habitat) | Distance from Proposed Development (km) | Potential adverse effect: Source-Pathway-Receptor Linkage |
|-----------------|---|---|--|
| | <p>maintain the favourable conservation condition of the Annex I habitats and Annex II species for which the SPA has been selected.</p> | | <ul style="list-style-type: none"> • storm drainage will be designed in accordance with the Greater Dublin Strategic Drainage Study (GDSDS) and incorporates normal sustainable drainage systems (SuDS) measures before discharging to the existing Uisce Éireann storm water network • installation of Modular Attenuation Units wrapped in a non-impermeable membrane and will including granular bedding, clause 505 and distribution pipe(s) Drawing S603 OCSC XX XX DR C 0620, Appendix II. • the development will involve connection to the existing Irish Water Foul Sewer network with storm water discharged via a petrol interceptor, attenuation tank, and flow control hydro brake, to the existing Local Authority Storm Water pipe network • if ground water is encountered during excavations, the water will be pumped from the excavation and discharged through a pumped main into the filtration bed • standard working procedures includes spill kits will be onsite at all times with suitably qualified trained personnel • the size and scale of the Project works within a Project area of 0.45 hectares. • works are temporary, short-term and localised; significant effects are not anticipated. • works will be undertaken under the guidance of an Ecological Clerk of Works. • works are temporary, short-term and localised; significant effects are not anticipated. • works will be undertaken under the guidance of an Ecological Clerk of Works |

European Sites closest to the Project are outlined in Figures 4.1 and 4.2 and include Cummeen Strand/Drumcliff Bay (Sligo Bay) SAC, Lough Gill SAC and Cummeen Strand SPA.

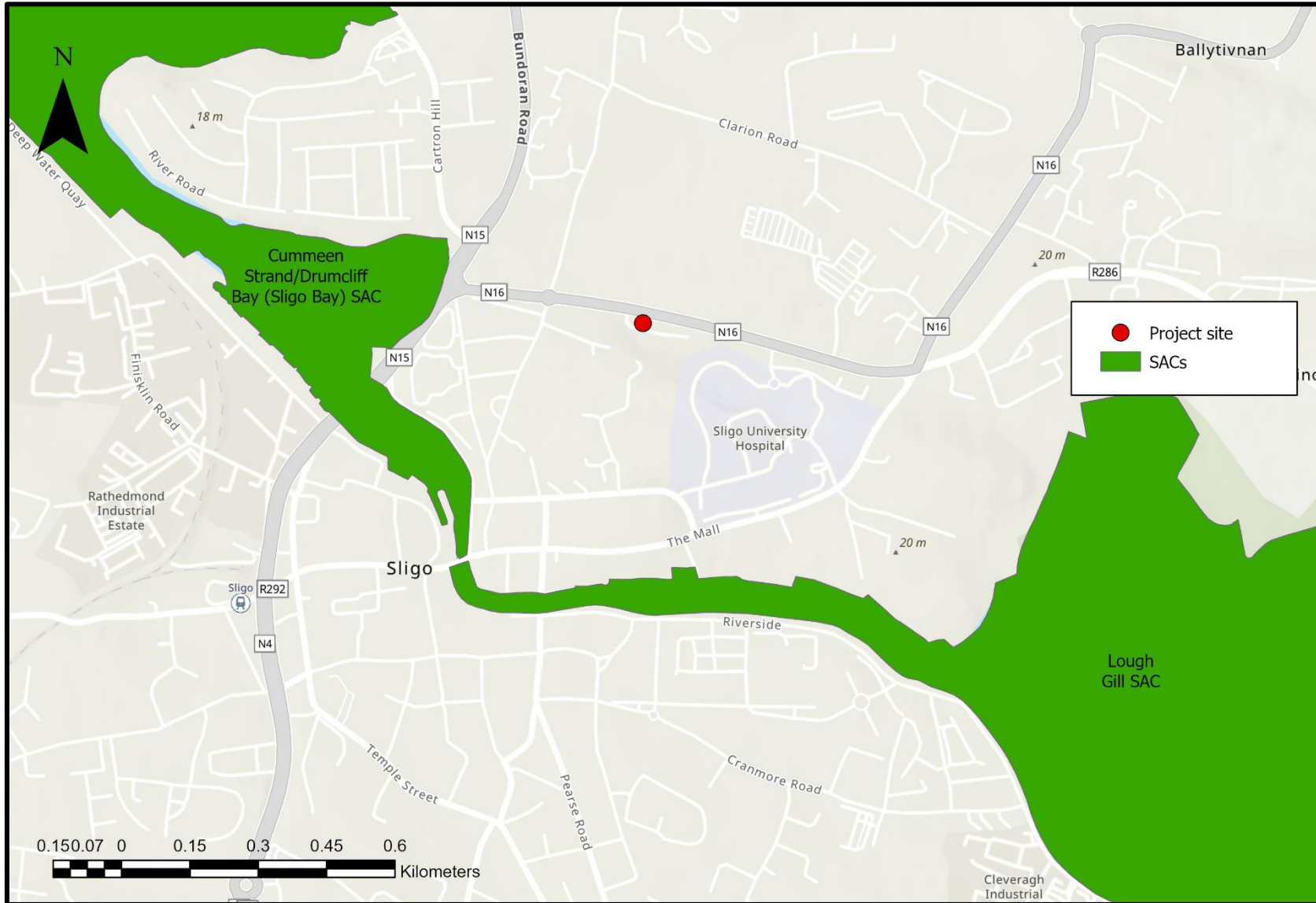

Figure 4.1: Project site showing the closest European SACs Sites

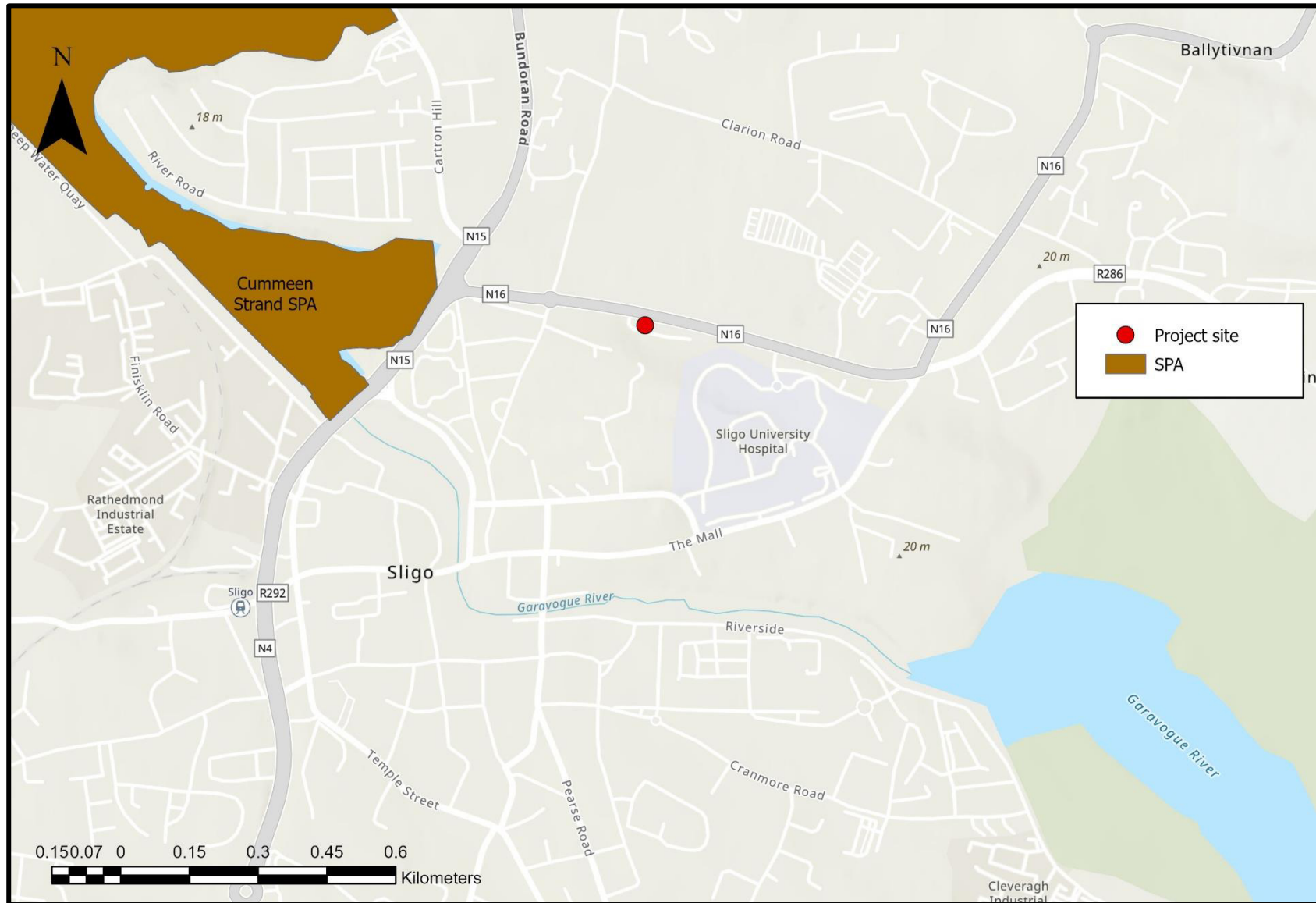

Figure 4.2: Project site showing the closest European SPA Site

4.2 IDENTIFICATION OF SOURCE PATHWAY RECEPTOR (SPR) MODEL PATHWAYS

Under the SPR model, the works associated with the construction and operation of the Project represent the source of potential impacts.

Pathways that could arise as a result of Project works and lead to potential impacts are listed below and an appraisal of these pathways potential to connect this Project to European Sites and their qualifying features of interest (which represent the receptors under the SPR model) is also provided:

- Emissions to surface water during demolition, construction and operation: There is a potential hydrological connection (via storm water drain) to the Sligo stream and a potential for a surface water pathway to arise and result in emissions to the Sligo River. Intervening landscape and land use will support the dissipation of any surface runoff from the site (Drawing No. S603-OCSC-XX-XX-DR-C-0620). Works are very localised and will occur within the Project site. Storm drainage for the entire development has been designed in accordance with the Greater Dublin Strategic Drainage Study (GDSDS). The storm water drainage design has been designed to cater for surface water from hard surfaces in the proposed development including roadways, footpaths, and the proposed buildings. A comprehensive Construction Methodology and EMP (Appendix II) has been developed for this site and will be adhered to during all works, including during the demolition, construction and operation phases
- Emissions to groundwater: The groundwater flood mapping confirmed that the site is not at risk from groundwater flooding with no historic record of groundwater flooding at the Project site. Given that the entirety of bedrock at the proposed work area is of Glencar Limestone, there is little risk of groundwater flooding. In addition, there is no risk of tidal or pluvial flooding at this site. Also, given that works will be carried out according to the methodology outlined in the Construction Methodology and EMP (Appendix II) pathways carrying nutrients, silt or contaminants to SAC/SPA groundwater are considered unlikely.
- Emissions to air: the Project site will not result in perceptible emissions to air. Significant adverse air emissions to any QI are not anticipated during construction or operation.
- Light emissions: the Project site is located in an urban area. Project works will only be carried out during daylight hours. Bat species are not qualifying features of the surrounding European Sites and therefore have no impact from any lighting issue as a result of this Project during construction or operation.
- Visual emissions: The Project works were not predicted to have the potential to result in visual emissions that could generate disturbance to qualifying species of any European Sites during construction or operation.
- Human disturbance pathway: Human disturbance to a European Site can occur as an indirect impact arising as a result of land use activities generated by a project. An example of such an indirect impact is an increase in human presence and associated pressures within a European Site. The potential for a human disturbance pathway, through which a proposed development could generate activity within European Sites and result in disturbance to qualifying habitats

or species is also identified as a potential pathway requiring examination. Given that the local area is likely currently subject to heavy human traffic from the local schools and proximate residential properties, the increase in human activity is unlikely to pose a new or combined significant effect on any qualifying interest of the nearby European Sites or any other European Site.

In light of the above screening assessment, no significant effects have been identified between the Project and any qualifying feature of a designated European Site during either construction or operation.

4.3 IN-COMBINATION EFFECTS

Planning Permission Applications

While effects on European Sites are not expected as a result of the construction and operation of the Project, the potential for cumulative effects on these designated sites due to other plans and projects acting in-combination with the Project are considered. The Sligo County Council on-line planning application portal was used to search planning applications close to the Project (August, 2023). A five-year search timeframe was assessed; Retention, refused and withdrawn planning applications were excluded. **Table 4.3** shows the planning applications in close proximity to the Project (circa 500m).

Table 4.3: Planning applications in close proximity to the Project.

| Planning Reference | Description of Development | Site Address | Decision Date | Distance from Site |
|--------------------|--|--|---------------|------------------------------------|
| 22444 | development consisting of installation of 320 no. photovoltaic (PV) panels on south facing pitched roofs of the existing hospital building and all associated works | St. John's Hospital, Ballytivnan, Sligo | 23/02/2023 | approx. 210m from the project site |
| 19517 | for development consisting of (a) construct a two storey extension to side of dwelling house, (b) remove existing rear extension and construct a single storey extension to rear of dwellinghouse, (c) construct a porch to front of dwelling house, (d) construct an off street car parking area adjacent to the public road | 34 St. John's Terrace, Sligo | 18/02/2020 | approx. 253m from the project site |
| 20199 | development consisting of the construction of an LPG gas compound consisting of 3 x 2 Tonne underground gas storage tanks with connection to existing boiler houses, truck set down/filling area and 4 additional car park spaces on the site at Markievicz House, Barrack Street, Rathquarter, Sligo. Constance Markievicz House is a Protected Structure | Markievicz House, Barrack Street, Rathquarter, Sligo | 20/08/2020 | approx. 435m from the project site |

| Planning Reference | Description of Development | Site Address | Decision Date | Distance from Site |
|--------------------|--|---|---------------|------------------------------------|
| | on the site and the proposed development lies within its curtilage | | | |
| 19344 | development consisting of the pay-to-use waste portable compactor for dry recyclables and a pay-to-use portable waste compactor for residual waste and food waste | Circle K Service Station, Cartron Hill, Sligo, F91 HH2Y | 18/06/2020 | approx. 438m from the project site |
| 22258 | development consisting of construction of detached single storey garden room with all associated works | Ard na Greine, Rosses Point Road, Cartron Hill, Sligo | 13/09/2022 | approx. 496m from the project site |
| 2046 | Development consisting of the construction of a new part single storey/part 2 storey 12 bed residential Hospice Facility extension adjoining Connaught Road, including associated support accommodation. Refurbishment and minor demolitions of the existing hospice facility including existing house and inpatient areas to become support accommodation. The development involves the construction of an undercroft car park, reconfiguration of existing associated car park, extensive landscape scheme to west and south and general minor associated works. The new extension is within the curtilage of a protected structure. | Sligo University Hospital, The Mall, Sligo | 31/03/2020 | approx. 423m from the project site |
| 21407 | development consisting of the demolition of derelict sheds, provide new yard area, build new bathroom, and a new entrance door. Provide new metal gate to match existing in rebuilt yard wall and all necessary ancillary works. The building is on R.P.S no 216SE | The Masonic Lodge, The Mall, Sligo | 01/12/2021 | approx. 438m from the project site |

There were no other planning applications in the area at the time of writing (August, 2023).

The AA Screening Assessment has shown there will be no likely significant effects to any European Site during the construction or operation of the Project. Works will be contained within the site; it is anticipated that there will be no in-combination impacts from any local planning applications.

5 SCREENING ASSESSMENT – CONCLUSION

It can be objectively concluded that there are not likely to be any significant effects on any European Site as a result of the construction or operation of the Project at Ash Lane, Co. Sligo. Therefore, an Appropriate Assessment is not required.

6 RECOMMENDATIONS

- A) Maintain native trees where possible onsite. If removing a tree or any part of a tree thereof, a bat roost suitability assessment should be carried out prior to any works commencing. It is highly recommended that a suitably qualified ecologist is appointed to advise further and conduct surveys on the presence of bats in or utilising the site. This information should be collected as early as possible in the design process, and certainly before final lighting detail is designed, so as to avoid the need for costly revisions. This Project has the potential to support bats.
- B) A lighting professional should be appointed to prepare a final lighting scheme design and/or lux calculations or undertake baseline light surveys as necessary. A dimming profile of the lighting system should be discussed and agreed with the local authority to avoid and /or reduce any harmful effects of new artificial lighting on local bats and their habitats. Lighting should avoid key habitats and features onsite, e.g. mature or developing trees. The lighting should demonstrate compliance with lux limits and buffers for all bat species frequenting the area. Bat and lighting monitoring may be required during operation.
- C) Native hedgerows / shrubbery should be planted where possible. Planting and specification methods should follow the outline in Appendix II of the Irish Water Biodiversity Guidance document IW-AMT-GL-021. Selection of plants should be informed by an ecologist. Similarly, any other new planting required onsite should follow the guidelines for such within the named IW document above. All nursery plants should be sourced from Ireland and not imported from abroad; this will reduce potential infestation of new pathogens and or invasive species and support biosecurity onsite.
- D) Prior to moving or removing any hedgerows/shrubbery, thermal imaging of any local mammals onsite is recommended; such mammals utilising the vegetation (hedgehogs, shrews etc.) can then be safely moved to alternate similar suitable sites nearby.

7 REFERENCES

Curtis, T.G.F. & McGough, H.N.(1988) The Irish Red Data Book 1: Vascular Plants. The Stationery Office, Dublin.

European Commission (2001) Assessment of Plans and Projects significantly affecting European Sites: Methodological guidance on the provisions of Article 6(3) and (4) of the Habitats Directive 92/43/EEC.

European Commission (2013) Interpretation manual of European Union habitats EUR 28. European Commission, DG Environment.

European Commission (2018) Managing Natura 2000 Sites: The Provisions of Article 6 of the 'Habitats Directive' 92/43/EEC.

European Union Birds Directive (1979) Council Directive 79/209/EEC of 2 April 1979 on the conservation of wild birds. Brussels: The Council of the European Communities.

European Union Habitats Directive (1992) Council Directives 92/43/EEC of 21 May 1992 on the conservation of natural habitats and of wild fauna and flora.

Fossitt, Julie A. (2000), *'A Guide to Habitats in Ireland'*, The Heritage Council, Kilkenny.

Sligo County Council (2021),

<http://lp4.sligococo.ie/LP4/default.aspx?topicname=Planning&featureid=0>

NPWS (2015) Conservation Objectives: Bunduff Lough and Machair/Trawalua/Mullaghmore SAC 000625. Version 1. National Parks and Wildlife Service, Department of Arts, Heritage and the Gaeltacht.

Office of the Planning Regulator (OPR) (2021). Appropriate Assessment Screening for Development Management. OPR Practice Note PN01.

O'Neill, F.H.; Martin, J.R.; Devaney, F.M.; Perrin, P.M., (2013) Irish semi-natural grasslands survey 2007-2012, Irish Wildlife Manuals, No. 78.

Parnell, J. & Curtis, T. (2012) *Webb's An Irish Flora*. Cork University Press, Cork.

Scannell, M J P and Synott, D M, 1987, *Census Catalogue of the Flora of Ireland*. Stationary Office, Dublin.

Scott Wilson, Levett-Therivel Sustainability Consultants, Treweek Environmental Consultants and Land Use Consultants (2006) Appropriate Assessment of Plans.

SNH, Marine Scotland Information, NatureScot <https://marine.gov.scot/data-owners/naturescot-previously-snh>

APPENDIX I
GROUND INVESTIGATIONS REPORT



CAUSEWAY
— GEOTECH

Glenview Housing Development – Ground Investigation

Client: Sligo County Council

Client's Representative: OCSC

Report No.: 23-0063

Date: March 2023

Status: Final for Issue

CONTENTS

Document Control Sheet

Note on: Methods of describing soils and rocks & abbreviations used on exploratory hole logs



| | | |
|---|---|----|
| 1 | AUTHORITY..... | 5 |
| 2 | SCOPE..... | 5 |
| 3 | DESCRIPTION OF SITE | 5 |
| 4 | SITE OPERATIONS..... | 6 |
| | 4.1 Summary of site works..... | 6 |
| | 4.2 Boreholes..... | 6 |
| | 4.3 Dynamic probes..... | 7 |
| | 4.4 Trial Pits..... | 7 |
| | 4.5 Slit trench | 7 |
| | 4.6 Infiltration tests..... | 7 |
| | 4.7 Indirect CBR test (DCP)..... | 7 |
| | 4.8 Surveying..... | 8 |
| | 4.9 GPR Survey..... | 8 |
| 5 | GROUND CONDITIONS..... | 8 |
| | 5.1 General geology of the area | 8 |
| | 5.2 Ground types encountered during investigation of the site | 8 |
| | 5.3 Groundwater..... | 9 |
| 6 | DISCUSSION..... | 10 |
| | 6.1 Proposed construction | 10 |
| | 6.2 Recommendations for construction | 10 |
| | 6.2.1 Summary..... | 10 |
| | 6.2.2 Soil strength parameters | 10 |
| | 6.2.3 Foundations and ground floor construction..... | 11 |
| | 6.2.4 Floor slabs | 12 |
| | 6.2.5 Excavations for services..... | 12 |
| | 6.2.6 Access roads, car parks and hard standing | 12 |
| | 6.3 Infiltration drainage | 13 |
| 7 | REFERENCES | 14 |



APPENDICES

| | |
|------------|--|
| Appendix A | Site and exploratory hole location plans |
| Appendix B | Borehole logs |
| Appendix C | Trial pit logs |
| Appendix D | Trial pit photographs |
| Appendix E | Slit trench logs and drawings |
| Appendix F | Slit trench photographs |
| Appendix G | Infiltration test results |
| Appendix H | Indirect in-situ CBR test results |
| Appendix I | SPT hammer energy measurement report |
| Appendix J | GPR Survey |

Document Control Sheet

| | | | | | |
|---|-----|---|-----------------|---|----------------------------|
| Report No.: | | 23-0063 | | | |
| Project Title: | | Glenview Housing Development | | | |
| Client: | | Sligo County Council | | | |
| Client's Representative: | | OCSC | | | |
| Revision: | A00 | Status: | Final for Issue | Issue Date: | 3 rd March 2023 |
| Prepared by: | | Reviewed by: | | Approved by: | |
|  Rachel White B.A. (Mod.) Geoscience | |  Sean Ross BSc MSc MIEI PGeo | |  Darren O'Mahony BSc MSc MIEI EurGeol PGeo | |

The works were conducted in accordance with:

British Standards Institute (2015) BS 5930:2015+A1:2020, Code of practice for ground investigations.

BS EN 1997-2: 2007: Eurocode 7 - Geotechnical design - Part 2 Ground investigation and testing.

Geotechnical Society of Ireland (2016), Specification & Related Documents for Ground Investigation in Ireland

METHODS OF DESCRIBING SOILS AND ROCKS

Soil and rock descriptions are based on the guidance in BS5930:2015+A1:2020, The Code of Practice for Ground Investigation.

| Abbreviations used on exploratory hole logs | |
|--|---|
| U | Nominal 100mm diameter undisturbed open tube sample (thick walled sampler). |
| UT | Nominal 100mm diameter undisturbed open tube sample (thin walled sampler). |
| P | Nominal 100mm diameter undisturbed piston sample. |
| B | Bulk disturbed sample. |
| LB | Large bulk disturbed sample. |
| D | Small disturbed sample. |
| C | Core sub-sample (displayed in the Field Records column on the logs). |
| L | Liner sample from dynamic sampled borehole. |
| W | Water sample. |
| ES / EW | Soil sample for environmental testing / Water sample for environmental testing. |
| SPT (s) | Standard penetration test using a split spoon sampler (small disturbed sample obtained). |
| SPT (c) | Standard penetration test using 60 degree solid cone. |
| (x,x/x,x,x,x) | Blows per increment during the standard penetration test. The initial two values relate to the seating drive (150mm) and the remaining four to the 75mm increments of the test length. |
| (Y for Z/ Y for Z) | Incomplete standard penetration test where the full test length was not achieved. The blows 'X' represent the total blows for the given seating or test length 'Z' (mm). |
| N=X | SPT blow count 'N' given by the summation of the blows 'X' required to drive the full test length (300mm). |
| HVP / HVR | In situ hand vane test result (HVP) and vane test residual result (HVR). Results presented in kPa. |
| V VR | Shear vane test (borehole). Shear strength stated in kPa. V: undisturbed vane shear strength VR: remoulded vane shear strength |
| Soil consistency description | In cohesive soils, where samples are disturbed and there are no suitable laboratory tests, N values may be used to indicate consistency on borehole logs – a median relationship of $N \times 5 = C_u$ is used (as set out in Stroud & Butler 1975). |
| dd-mm-yyyy | Date at the end and start of shifts, shown at the relevant borehole depth. Corresponding casing and water depths shown in the adjacent columns. |
| ▽ | Water strike: initial depth of strike. |
| ▼ | Water strike: depth water rose to. |
| Abbreviations relating to rock core – reference Clause 36.4.4 of BS 5930: 2015+A1:2020 | |
| TCR (%) | Total Core Recovery: Ratio of rock/soil core recovered (both solid and non-intact) to the total length of core run. |
| SCR (%) | Solid Core Recovery: Ratio of solid core to the total length of core run. Solid core has a full diameter, uninterrupted by natural discontinuities, but not necessarily a full circumference and is measured along the core axis between natural fractures. |
| RQD (%) | Rock Quality Designation: Ratio of total length of solid core pieces greater than 100mm to the total length of core run. |
| FI | Fracture Index: Number of natural discontinuities per metre over an indicated length of core of similar intensity of fracturing. |
| NI | Non Intact: Used where the rock material was recovered fragmented, for example as fine to coarse gravel size particles. |
| AZCL | Assessed zone of core loss: The estimated depth range where core was not recovered. |
| DIF | Drilling induced fracture: A fracture of non-geological origin brought about by the rock coring. |
| (xxx/xxx/xxx) | Spacing between discontinuities (minimum/average/maximum) measured in millimetres. |

Glenview Housing Development

1 AUTHORITY

On the instructions of OCSC, (“the Client’s Representative”), acting on the behalf of Sligo County Council (“the Client”), a ground investigation was undertaken at the above location to provide geotechnical and environmental information for input to the design and construction of a proposed residential development.

This report details the work carried out both on site and in the geotechnical and chemical testing laboratories; it contains a description of the site and the works undertaken, the exploratory hole logs and the laboratory test results. A discussion on the recommendations for construction is also provided.

All information given in this report is based upon the ground conditions encountered during the ground investigation works, and on the results of the laboratory and field tests performed. However, there may be conditions at the site that have not been taken into account, such as unpredictable soil strata, contaminant concentrations, and water conditions between or below exploratory holes. It should be noted that groundwater levels usually vary due to seasonal and/or other effects and may at times differ to those recorded during the investigation. No responsibility can be taken for conditions not encountered through the scope of work commissioned, for example between exploratory hole points, or beneath the termination depths achieved.

This report was prepared by Causeway Geotech Ltd for the use of the Client and the Client’s Representative in response to a particular set of instructions. Any other parties using the information contained in this report do so at their own risk and any duty of care to those parties is excluded.

2 SCOPE

The extent of the investigation, as instructed by the Client’s Representative, included boreholes, trial pits, a slit trench, soil sampling, in-situ testing, and the preparation of a report on the findings including recommendations for construction.

3 DESCRIPTION OF SITE

As shown on the site location plan in Appendix A, the works were conducted on the site of Glenview Park, located north of Sligo Town. The site is bordered by Glenview Housing Development Phase 1 to the east, Stephen McDonagh Place to the west, The N16 to the north and grasslands to the south .

Elevations vary across the site, with a slight rise in elevation towards the south-east. The existing houses on the south side of the site have been cut into an existing slope which has resulted in very steep slopes in the green area on the south side of the site.

4 SITE OPERATIONS

4.1 Summary of site works

Site operations, which were conducted between the 23rd of February and the 1st of March 2023, comprised:

- four boreholes by dynamic (windowless) sampling
- three follow-on dynamic probes
- two machine dug trial pits
- an infiltration test performed in two trial pits
- one machine and hand-dug slit trench; and
- indirect CBR tests at one location.

The exploratory holes and in-situ tests were located as instructed by the Client's Representative, and as shown on the exploratory hole location plan in Appendix A.

4.2 Boreholes

Four boreholes (BH01-BH04) were put down to completion by light percussion boring techniques using a Dando Terrier dynamic sampling rig. The boreholes were put down initially in 150mm diameter, reducing in diameter with depth as required, down to 50mm by use of the smallest sampler.

Hand dug inspection pits were carried out between ground level and 1.20m depth to ensure boreholes were put down clear of services or subsurface obstructions. The boreholes were taken to depths ranging between 2.00m and 4.00m where they were terminated on encountering virtual refusal.

Disturbed (bulk and small bag) samples were taken within the encountered strata.

Standard penetration tests were carried out in accordance with BS EN 22476-3:2005+A1:2011 at standard depth intervals using the split spoon sampler (SPT_(s)) or solid cone attachment (SPT_(c)). The penetrations are stated for those tests for which the full 150mm seating drive or 300mm test drive was not possible. The *N*-values provided on the borehole logs are uncorrected and no allowance has been made for energy ratio corrections. The SPT hammer energy measurement report is provided in Appendix I.

Any water strikes encountered during boring were recorded along with any changes in their levels as the borehole proceeded. Details of the water strikes are presented on the individual borehole logs.

Appendix B presents the borehole logs.

4.3 Dynamic probes

Three dynamic probes were conducted as a follow on from BH02-BH04 using the DPSHB method as described in BS EN ISO 22476-3:2005+A1:2011. The method entails a 63.5kg hammer falling 0.75m onto a 50.5mm diameter cone with an apex angle of 90°.

Appendix B provides the dynamic probe logs on the sheet following the relevant borehole log in the form of plots, against depth, of the number of blows per 100mm penetration.

4.4 Trial Pits

Two trial pits (TP02–TP03) were excavated using a 3t tracked excavator fitted with a 300mm wide bucket, to depths of 1.70m and 1.60m respectively.

Disturbed (small jar and bulk bag) samples were taken at standard depth intervals and at change of strata.

No groundwater strikes were encountered during excavation of the pits. The stability of the trial pit walls was noted on completion.

Appendix C presents the trial pit logs with photographs of the pits and arising provided in Appendix D.

4.5 Slit trench

One slit trench (ST01) was excavated by a combination of hand digging and mechanical excavation using a compact 3t tracked excavator fitted with a 300mm wide toothless bucket, to locate and identify buried services at the site.

Drawings of the trench and the locations of services encountered during excavation are shown along with the slit trench log in Appendix E, with photographs presented in Appendix F.

4.6 Infiltration tests

An infiltration/soakaway test was carried out at two locations (IT01- IT02) in accordance with BRE Digest 365 - Soakaways (BRE, 2016). The tests were conducted in similarly numbered trial pits.

Appendix G presents the results and analysis of the infiltration test with photographs of the pits shown in Appendix D.

4.7 Indirect CBR test (DCP)

An indirect CBR test was conducted at one location (TP02, undertaken twice due to early refusal) using a Dynamic Cone Penetrometer (DCP). The equipment was developed in conjunction with the UK Transport Research Laboratory, and is discussed in Highways England CS229 (2020) which refers to the methodology described in TRL Overseas Road Note 18 (1999).

The test results are presented in Appendix H in the form of plots of the variation with depth of the penetration per blow. Straight lines have been fitted to the plots and the CBR for each depth range estimated using the following relationship, which is taken from TRRL Overseas Road Note 8 (1990), *A user's manual for a program to analyse dynamic cone penetrometer data*.

$$\text{Log CBR} = 2.48 - 1.057 \text{ Log (mm/blow)}$$

The frequently elevated CBR values are a consequence of the coarse-grained content of the penetrated soils and are often not representative of the soil matrix.

4.8 Surveying

The as-built exploratory hole positions were surveyed following completion of site operations by a Site Engineer from Causeway Geotech. Surveying was carried out using a Trimble R10 GPS system employing VRS and real time kinetic (RTK) techniques.

The plan coordinates (Irish Transverse Mercator) and ground elevation (mOD Malin) at each location are recorded on the individual exploratory hole logs. The exploratory hole location plan presented in Appendix A shows these as-built positions.

4.9 GPR Survey

A Ground Penetrating Radar (GPR) Survey was undertaken by Scantech Geoscience Ltd. Across the site on the 15th February 2023, to identify the presence of any unknown services and verify the location of known services running through the area.

The findings of the GPR survey are presented in Appendix J.

5 GROUND CONDITIONS

5.1 General geology of the area

Published geological mapping indicate the superficial deposits underlying the site comprise alluvium and glacial till. These deposits are underlain by dark fine limestones and calcareous shales of the Glencar Limestone Formation.

5.2 Ground types encountered during investigation of the site

A summary of the ground types encountered in the exploratory holes is listed below, in approximate stratigraphic order:

- **Paved surface:** BH03 and BH04 encountered 150mm of concrete surfacing.

- **Topsoil:** encountered in 200mm thickness on BH01 and BH02.
- **Made Ground (sub-base):** approximately 350mm of aggregate fill beneath the paved surface in BH03 and BH04.
- **Made Ground (fill):** reworked sandy gravelly clay fill with varying fragments of steel and red brick extending to depths of 1.10-2.00m was encountered in BH01, BH02, IT01-IT02, ST01 and TP02-TP03.
- **Alluvium:** Very soft dark grey/black organic clays encountered in the northern part of the site.
- **Glacial Till:** sandy gravelly clay, frequently with low cobble content, typically firm or stiff in upper horizons, becoming very stiff with increasing depth.

5.3 Groundwater

Details of the individual groundwater strikes, along with any relative changes in levels as works proceeded, are presented on the exploratory hole logs for each location.

Groundwater was encountered during the ground investigation as water strikes shown in Table 1.

Table 1. Groundwater strikes encountered during the ground investigation.

| Location | Depth (mbgl) | Comments |
|----------|--------------|--|
| BH01 | 3.00 | Water rose from 3.00m to 2.85m over 20 minutes |
| IT02 | 0.65 | Fast seepage |

Groundwater was not noted during drilling of BH02. However, it should be noted that the casing used in supporting the borehole walls during drilling may have sealed out additional groundwater strikes and the possibility of encountering groundwater during excavation works should not be ruled out.

Groundwater was not noted during excavation of any of the other pits or trenches.

Seasonal variation in groundwater levels should also be factored into design considerations.

6 DISCUSSION

6.1 Proposed construction

It is proposed to construct additional housing within the current development with associated infrastructure.

No further details were available to Causeway Geotech at the time of preparing this report and any designs based on the recommendations or conclusions within this report should be completed in accordance with the current design codes, taking into account the variation and the specific details contained within the exploratory holes. Causeway Geotech were commissioned to provide a geotechnical report, and it is outwith our remit to advise on structure design.

6.2 Recommendations for construction

6.2.1 Summary

Based on the presence of stiff glacial till at relatively shallow depths across the southern side of the development, the implementation of traditional shallow (spread) foundations (strip/pad and trench fill) are considered suitable.

However, on the north side, the thickness of made ground and alluvial deposits makes the implementation of traditional shallow (spread) foundations unsuitable. Consequently, an alternative foundation method should be sought such as a raft type or if economically feasible a mini-piled solution.

Should piling be adopted as the preferred foundation type, it is highly recommended that further ground investigation works involving rotary drilling be carried out to prove ground conditions beyond the depths achieved in this ground investigation.

6.2.2 Soil strength parameters

When estimating the shear strength of fine soils (silt/clay), reference is made to the results of Standard Penetration Tests (SPT's) carried out within the boreholes. The undrained shear strength of fine soils can be estimated using the correlation developed by Stroud & Butler:

$$C_u = f_1 \times N$$

where f_1 is typically in the range 4 to 6. A median f_1 value of 5 is adopted for this report.

For granular soils (sand/gravel), a graphical relationship between SPT "N" value and angle of shearing resistance, ϕ , has been developed by Peck, Hanson and Thorburn. This is published in *Foundation Design and Construction* (Tomlinson, 2001) and is referenced in this report when deriving angles of shearing resistance for the gravel soils.

6.2.3 Foundations and ground floor construction

Foundations should transfer loading to below any Made Ground or subsoil. The recommended foundation construction and allowable bearing pressure (ABP) at the borehole locations are presented in Table 1.

Table 1: Construction recommendations

| Borehole | Depth below EGL* to suitable bearing stratum | Estimated ABP (kPa) | Strata description | Foundation type | Ground floor construction | Groundwater |
|----------|--|---------------------|--------------------|---|---------------------------|-----------------|
| BH01 | 3.00m | 180 | Stiff CLAY | Trench Fill (With side support and possible dewatering) | Suspended | Strike at 3.00m |
| BH02 | >4.50m | 200 | Stiff CLAY | Piled | Suspended | Not encountered |
| BH03 | 1.20m | 200 | Stiff CLAY | Strip & pad | Ground bearing | Not encountered |
| BH04 | 1.20m | 90 | Firm CLAY | Strip & pad | Ground bearing | Not encountered |

*Existing Ground Level

Based on the findings of the ground investigation, spread foundations (strip/pad) are considered suitable on the southern side with estimated allowable bearing pressures between 90kPa and 200kPa at depths 1.20m on firm to stiff clay.

The base of foundation excavations should be thoroughly inspected in accordance with the Earthworks Specification; any soft or loose soils removed with the resultant void backfilled with ST1 concrete or engineered backfill. A consistent bearing stratum should be provided for any building unit to limit differential settlements.

Given the generally fine grained/cohesive nature of the soils throughout the proposed formation levels, excavations for foundations are likely to be relatively stable. However, any instability can be minimised by battering the side slopes at 2 vertical to 1 horizontal and by limiting the duration that the excavation is open. Groundwater control, where required, will be possible by pumping from sumps formed in the base of excavations.

However, on the northern side, extensive alluvial and made ground deposits were encountered. This will prohibit the utilisation of any traditional strip/pad foundations due to the low bearing capacity of the upper soils. An alternative solution should be sought which should consider the extent of the soft strata to 4.50m in BH02.

Given the anticipated loads will be relatively low for a single storey dwelling, a raft type solution is more likely. Mini-piling would also be an option, however the Client's design team would need to balance the pro's and con's of both types of foundations and if a large area of soil is to be excavated and replace (E&R) it may be more cost effective to use a mini-pile solution.

6.2.4 Floor slabs

Floor slabs should not bear directly onto Made Ground or soft soils. Consequently, the use of ground bearing floor slabs is considered appropriate following the removal of any surface Made Ground and soft clay layers and their replacement using well-graded well-compacted granular fill. However, a suspended floor slab should be adopted where the difference in levels of the proposed floor and the base of Made Ground/soft soils is greater than 600mm.

Therefore, given the depth to the base of Made Ground and relative low strength of upper soil layers, a suspended floor slab will be required on the northern side of the site. be required over parts of the site.

6.2.5 Excavations for services

For the installation of services ducts/trenches, it is suggested that open trenching will be the most practicable construction method. Generally speaking, the ground conditions should render the use of open trenching by backhoe excavator possible, with some trench support likely required given the extent of made ground and alluvium encountered on the northern side of the site during the ground investigation.

Where working in open trenches, it is thought that trench support systems, by way of a trench box (or possibly sheet piles), will be required to maintain trench stability and safe working conditions. Groundwater control at these locations should be possible by means of sump pumping.

To preclude the eventuality of differential settlements in pipes, they should be laid on a consistent stratum of appropriate allowable bearing capacity and protected with appropriate fill cover.

Where ducts and chambers must be installed in areas where localised soft spots are encountered, the use of geogrid reinforcement along the base of the excavation is recommended. This will stiffen the base of the trench and help control longitudinal differential settlement.

Backfilling of trenches may be completed by using compacted Cl 804 granular fill and reinstated as appropriate.

6.2.6 Access roads, car parks and hard standing

Based on a summary of the CBR tests undertaken at the site, it is envisaged that the upper strata across the site may potentially be suitable for the placement of road make up layers. The two areas tested in the north of the site indicated CBR >2.5% at a depth of 200-300mm or >3.7% at a depth of 500mm. However, it should be noted that the material tested was made ground or alluvium, and this is evident in the variability in the results.

Table 2.1 of volume 7 section 2 of the Design Manual for Roads and Bridges (below), gives guidance on the average thickness of the pavement layers in relation to the CBR results. As can be seen, a CBR in excess of 3.7% requires a 460mm thick capping layer.

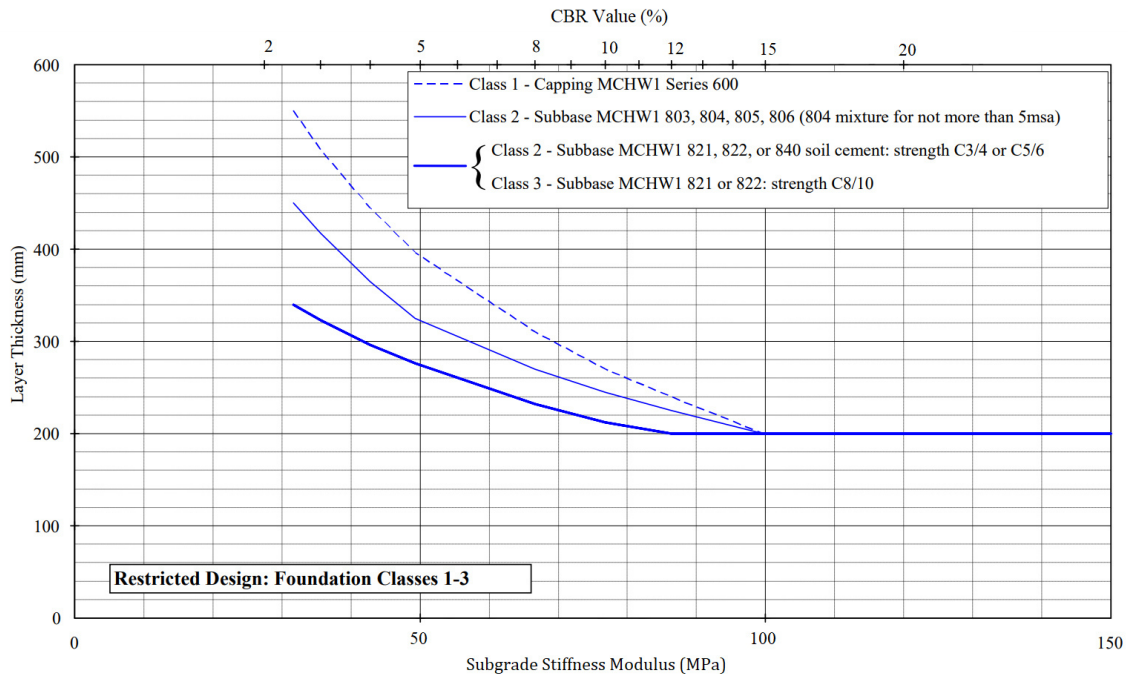

Table 2.1 (DMRB Vol.7 Sec2) 2009

Given the extent of alluvium and or made ground in the northern section of the site, it would be prudent to undertake further testing during the course of construction works at intervals as set out in the Earthworks Specification, and should any areas indicate lower than expected value, the above plot should be used to determine the thicknesses of any capping or sub-base layers that may need to be placed in these areas.

The use of geosynthetics in the construction of paved areas, will be beneficial, particularly in areas of Made Ground. These could include a geosynthetic (e.g., a geogrid) at subgrade level with further benefit gained by incorporating further layer(s) within the capping/sub-base layer. Road design should be undertaken by a specialist earthworks contractor/designer.

6.3 Infiltration drainage

In infiltration test carried out in IT01 and IT02, The absence of outflow precluded the calculation of any infiltration coefficients. The low-permeability fine-grained soils are therefore considered to be poor infiltration media, and would be deemed unsuitable for the implementation of infiltration drainage systems.

Reference should be made the Sustainable Drainage Systems (SuDS) design guidance, taking into account meteorological conditions and a hydrogeological assessment.

7 REFERENCES

Geotechnical Society of Ireland (2016), Specification & Related Documents for Ground Investigation in Ireland.

IS EN 1997-2: 2007: Eurocode 7 - Geotechnical design - Part 2 Ground investigation and testing. National Standards Authority of Ireland.

BS 5930: 2015+A1:2020: Code of practice for ground investigations. British Standards Institution.

BS EN ISO 14688-1:2018: Geotechnical investigation and testing. Identification and classification of soil. Part 1 Identification and description.

BS EN ISO 14688-2:2018: Geotechnical investigation and testing. Identification and classification of soil. Part 2 Principles for a classification.

BS 1377: 1990: Methods of test for soils for civil engineering purposes. British Standards Institution.

BS EN ISO 22476-3:2005+A1:2011: Geotechnical investigation and testing. Field testing. Standard penetration test.

Building Research Establishment (2005) BRE Special Digest 1, Concrete in aggressive ground.

Building Research Establishment (2007), BRE Digest 365: Soakaways.



CAUSEWAY
— GEOTECH

APPENDIX A
SITE AND EXPLORATORY HOLE LOCATION PLANS

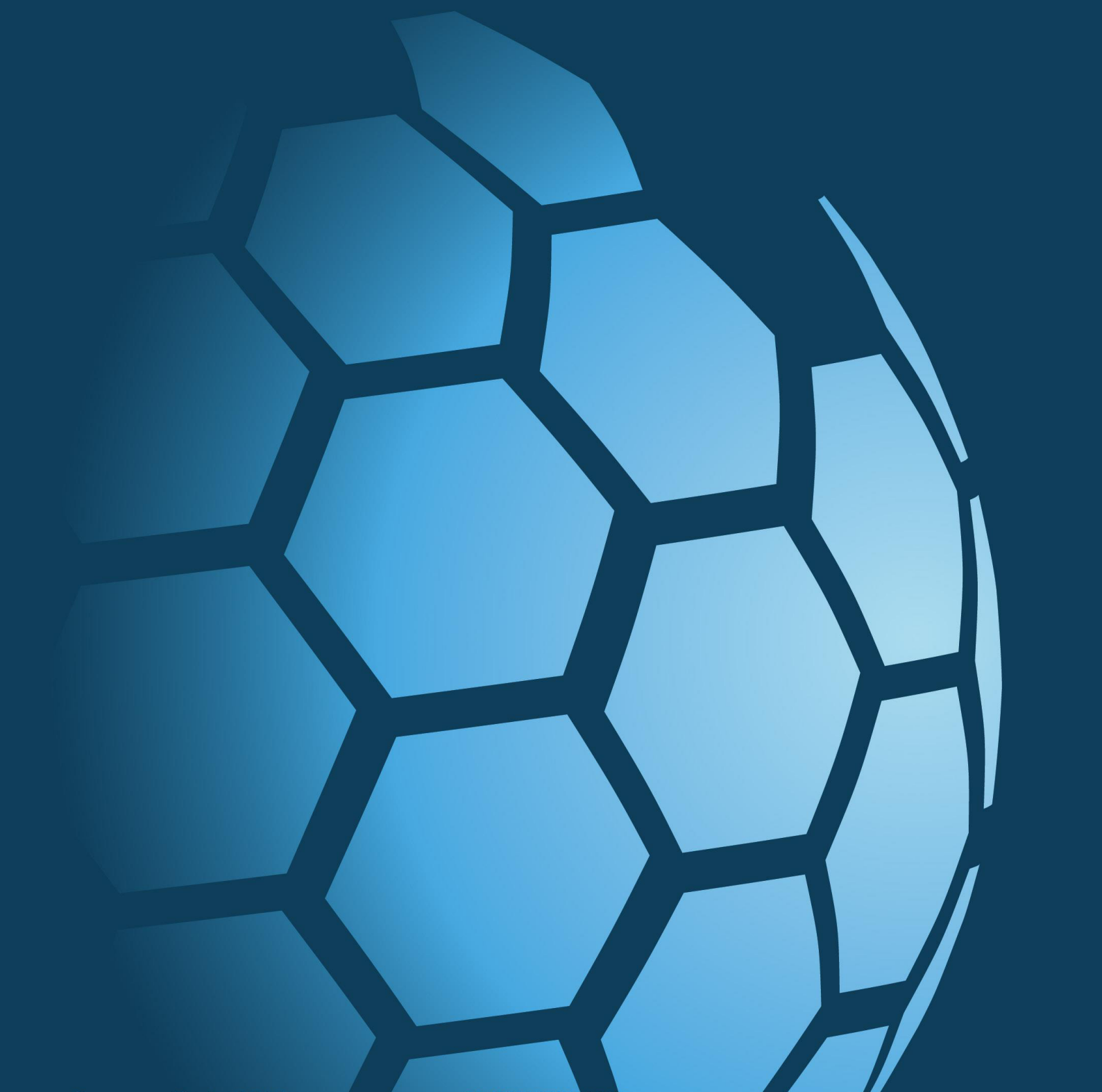

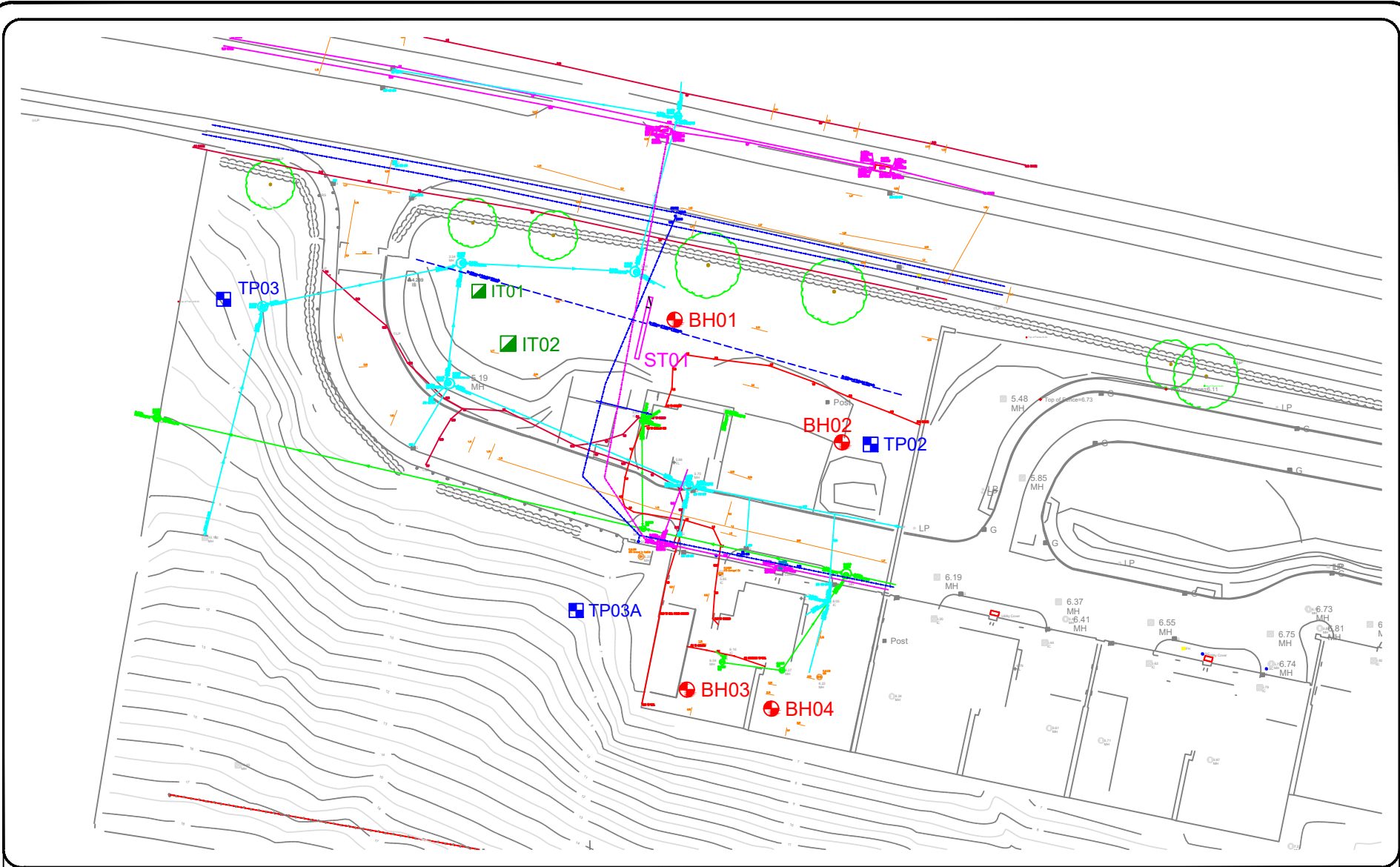

| | | | | |
|---------------------------------------|--|---|---------------|------------------|
| PROJECT: Glenview Housing Development | | TITLE: Exploratory hole location plan | | |
| CLIENT: Sligo County Council | KEY: ● Borehole ■ Infiltration Test ■ Trial Pit □ Silt Trench |  CAUSEWAY GEOTECH | SCALE: NTS@A3 | DATE: 03/03/2023 |
| ENGINEER: OCSC | | | DRWN: BS | SERIES: 1 of 1 |
| | | CHCK: SR | | |



CAUSEWAY
— GEOTECH

APPENDIX B
BOREHOLE LOGS

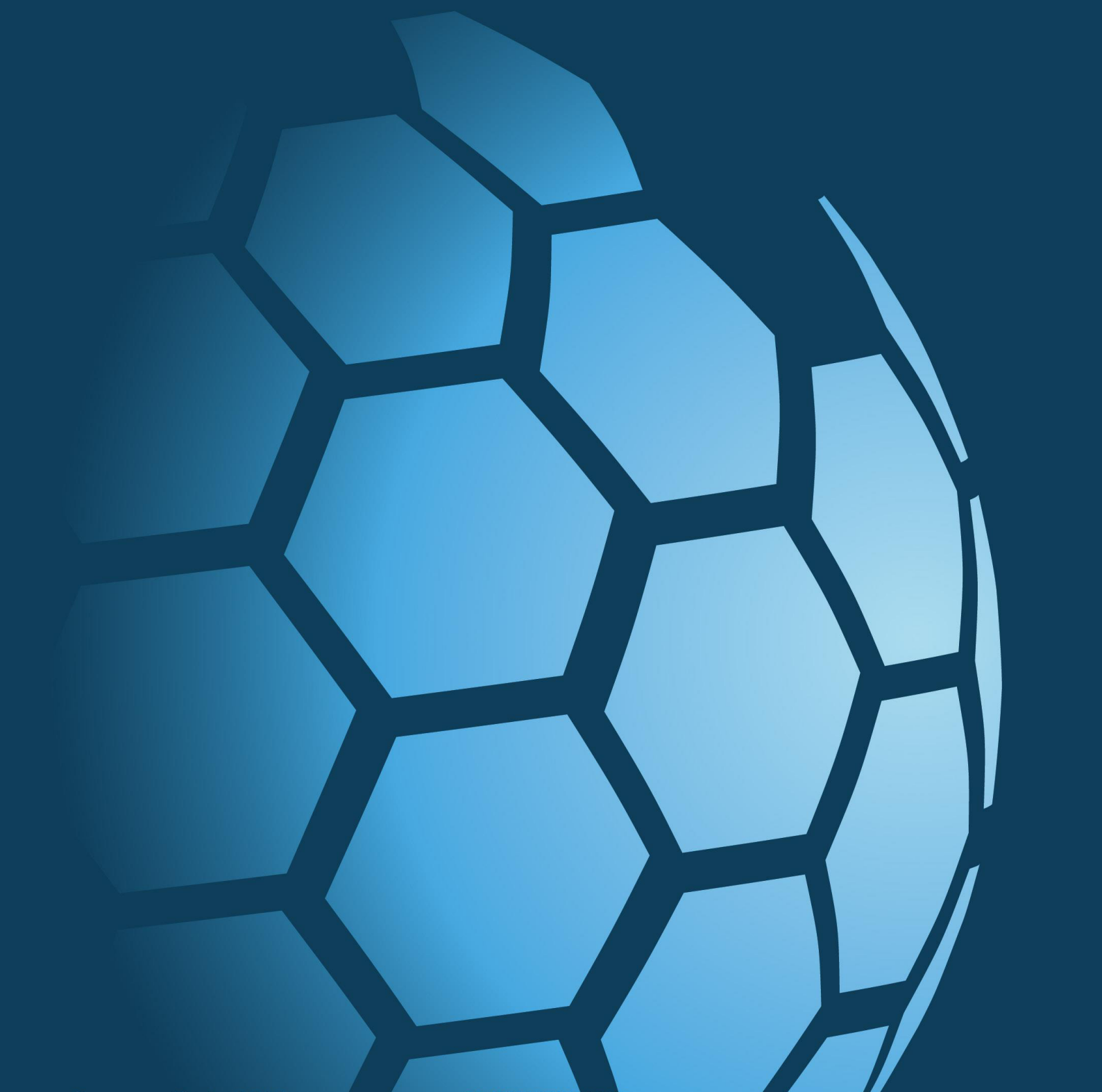



| | | | | | | | | |
|------------------|-------------------|----------------|-----------------|----------------------------|----------------------------|-------------------------------|--------------------|-----------------------------|
| Method | Plant Used | Top (m) | Base (m) | Coordinates | Final Depth: 3.80 m | Start Date: 24/02/2023 | Driller: JC | Sheet 1 of 1 Scale: 1:50 |
| Dynamic Sampling | Dando Terrier | 0.00 | 3.80 | 569509.10 E 836587.45 N | Elevation: 4.17 mOD | End Date: 24/02/2023 | Logger: SR | |

| Depth (m) | Sample / Tests | Field Records | Casing Depth (m) | Water Depth (m) | Level mOD | Depth (m) | Legend | Description | Water | Backfill |
|-------------|----------------|---|------------------|-----------------|-----------|-----------|--|--------------------------|-------|----------|
| 0.20 - 1.00 | B1 | | | | 3.97 | 0.20 | TOPSOIL | | | |
| 1.00 - 2.00 | B2 | | | | | | MADE GROUND: Very soft dark orangish brown sandy gravelly CLAY with low cobble content. Sand is fine to coarse. Gravel is subangular fine to coarse. Cobbles are subrounded. | | | |
| 1.20 - 1.65 | SPT (C) | N=3 (0,1/1,1,0,1) Hammer SN = 1367 | 0.00 | Dry | | | | | | |
| 2.00 - 3.00 | B3 | | | | 2.17 | 2.00 | Very soft light brown sandy gravelly SILT with low cobble content. Sand is fine to coarse. Gravel is angular fine to coarse. Cobbles are subrounded. | | | |
| 2.00 - 2.45 | SPT (C) | N=1 (1,0/1,0,0,0) Hammer SN = 1367 | 0.00 | Dry | | | | | | |
| 3.00 - 3.60 | B4 | | | | 1.17 | 3.00 | Stiff becoming very stiff light brown sandy gravelly SILT with low cobble content. Sand is fine to coarse. Gravel is angular fine to coarse. Cobbles are subrounded. | | | |
| 3.00 - 3.45 | SPT (C) | N=18 (2,1/3,9,2,4) Hammer SN = 1367 Strike at 3.00m. | 0.00 | Dry | | | | | | |
| 3.60 - 3.80 | SPT (C) | N=50 (25 for 75mm/50 for 125mm) Hammer SN = 1367 | 0.00 | Dry | 0.37 | 3.80 | | End of Borehole at 3.80m | | |

| Water Strikes | | | | Casing Details | | Remarks |
|-----------------------------------|---------------|------------|-------------|----------------|----------|-----------------------------------|
| Struck at (m) | Casing to (m) | Time (min) | Rose to (m) | To (m) | Diameter | |
| 3.00 | 0.00 | 20 | 2.85 | | | Inspection pit hand dug to 1.20m. |
| Termination Reason | | | | | | Last Updated |
| Terminated at refusal of sampler. | | | | | | 03/03/2023 |





| | | | | | | | | |
|------------------|-------------------|----------------|-----------------|----------------------------|----------------------------|-------------------------------|--------------------|-----------------------------|
| Method | Plant Used | Top (m) | Base (m) | Coordinates | Final Depth: 4.00 m | Start Date: 23/02/2023 | Driller: JC | Sheet 1 of 1 Scale: 1:50 |
| Dynamic Sampling | Dando Terrier | 0.00 | 4.00 | 569529.56 E 836572.45 N | Elevation: 5.80 mOD | End Date: 23/02/2023 | Logger: SR | |

| Depth (m) | Sample / Tests | Field Records | Casing Depth (m) | Water Depth (m) | Level mOD | Depth (m) | Legend | Description | Water | Backfill |
|-------------|----------------|------------------------------------|------------------|-----------------|-----------|-----------|--|--|-------|----------|
| 0.20 - 1.00 | B1 | | | | 5.60 | 0.20 | TOPSOIL | | | |
| 1.00 - 2.00 | B2 | | | | 4.80 | 1.00 | MADE GROUND: Soft dark brown sandy gravelly CLAY with low cobble content. Sand is fine to coarse. Gravel is subangular fine to coarse. | | | |
| 1.20 - 1.65 | SPT (C) | N=1 (0,0/0,0,0,1) Hammer SN = 1367 | 0.00 | Dry | | | | Very soft dark brownish grey sandy gravelly CLAY with low cobble content. Sand is fine to coarse. Gravel is subangular fine to coarse. | | |
| 2.00 - 3.00 | B3 | | | | 3.80 | 2.00 | | Very soft light brown sandy gravelly SILT with low cobble content. Sand is fine to coarse. Gravel is subangular fine to coarse. | | |
| 2.00 - 2.45 | SPT (C) | N=0 (0,0/0,0,0,0) Hammer SN = 1367 | 0.00 | Dry | | | | | | |
| 3.00 - 4.00 | B4 | | | | 2.80 | 3.00 | | Soft light brown gravelly sandy SILT with low cobble content. Sand is fine to coarse. Gravel is subrounded fine to coarse. | | |
| 3.00 - 3.45 | SPT (C) | N=4 (0,0/1,1,1,1) Hammer SN = 1367 | 0.00 | Dry | | | | | | |
| 4.00 - 4.45 | SPT (C) | N=6 (1,1/2,1,0,3) Hammer SN = 1367 | 0.00 | Dry | 1.80 | 4.00 | | End of Borehole at 4.00m | | |

| Water Strikes | | | | Casing Details | | Remarks |
|-----------------------------|---------------|------------|-------------|----------------|----------|--|
| Struck at (m) | Casing to (m) | Time (min) | Rose to (m) | To (m) | Diameter | |
| | | | | | | Inspection pit hand dug to 1.20m. No groundwater encountered. |
| Termination Reason | | | | | | Last Updated |
| Continued by dynamic probe. | | | | | | 03/03/2023 |





CAUSEWAY
GEOTECH

| | | | | | |
|--|--|-----------------------------|----------------------------|--------------------------------------|--------------|
| Project No. 23-0063 | Project Name: Glenview Housing Development | | | Probe ID BH02DP | |
| Coordinates 569529.56 E 836572.45 N | Client: Sligo County Council Client's Representative: OCS | | | | |
| Method: Dynamic Probing | | | | Sheet 1 of 1 Scale: 1:50 | |
| Probe Type: DPSH-B | Elevation 5.80 mOD | Final Depth: 5.00 | Date: 23/02/2023 | Operator: JC | FINAL |

| Depth (m) | Blows/100mm | | | | Torque (Nm) |
|-----------|-------------|-------|-------|-------|-------------|
| | 0-10 | 10-20 | 20-30 | 30-40 | |
| 1 | | | | | |
| 2 | | | | | |
| 3 | | | | | |
| 4 | | | | | |
| 5 | 1 | 11 | 22 | | 50 |
| 6 | | | | | |
| 7 | | | | | |
| 8 | | | | | |
| 9 | | | | | |

| | | | |
|--------------------------------|---|-----------------------------------|--|
| Fall Height: 750 mm | Remarks Termination Reason Terminated on refusal. | Last Updated 03/03/2023 | |
| Hammer Mass: 64 kg | | | |
| Cone Diameter: 51 mm | | | |



Project No.
23-0063

Project Name: Glenview Housing Development

Borehole ID

Client: Sligo County Council

BH03

Client's Rep: OCS

| | | | | | | | | |
|------------------|-------------------|----------------|-----------------|----------------------------|----------------------------|-------------------------------|--------------------|-----------------------------|
| Method | Plant Used | Top (m) | Base (m) | Coordinates | Final Depth: 2.00 m | Start Date: 23/02/2023 | Driller: JC | Sheet 1 of 1 Scale: 1:50 |
| Dynamic Sampling | Dando Terrier | 0.00 | 2.00 | 569510.59 E 836542.18 N | Elevation: 6.02 mOD | End Date: 23/02/2023 | Logger: SR | |

| Depth (m) | Sample / Tests | Field Records | Casing Depth (m) | Water Depth (m) | Level mOD | Depth (m) | Legend | Description | Water | Backfill |
|-------------|----------------|---------------------------------------|------------------|-----------------|-----------|-----------|--|--------------------------|-------|----------|
| 0.15 - 0.40 | B2 | | | | 5.87 | 0.15 | CONCRETE | | | |
| 0.40 - 2.00 | B3 | | | | 5.62 | 0.40 | MADE GROUND: Light grey slightly sandy subangular fine to coarse GRAVEL with medium cobble content. Sand is fine to coarse. Stiff becoming very stiff light brownish grey sandy gravelly CLAY with low cobble content. Sand is fine to coarse. Gravel is angular fine to coarse. | | | |
| 1.20 - 1.65 | D1 | | | | | | | | | |
| 1.20 - 1.65 | SPT (S) | N=22 (12,4/6,6,5,5) Hammer SN = 1367 | 0.00 | Dry | | | | | | |
| 2.00 - 2.45 | SPT (C) | N=33 (11,8/7,11,9,6) Hammer SN = 1367 | 0.00 | Dry | 4.02 | 2.00 | | End of Borehole at 2.00m | | |

| Water Strikes | | | | Casing Details | | Remarks |
|---|---------------|------------|-------------|----------------|----------|--|
| Struck at (m) | Casing to (m) | Time (min) | Rose to (m) | To (m) | Diameter | |
| | | | | | | Inspection pit hand dug to 1.20m. No groundwater encountered. |
| Termination Reason | | | | | | Last Updated |
| Terminated at refusal of sampler. Continued by dynamic probe. | | | | | | 03/03/2023 |





CAUSEWAY
GEOTECH

| | | | | |
|--|--|-----------------------------|----------------------------|---|
| Project No. 23-0063 | Project Name: Glenview Housing Development | | | Probe ID BH03DP |
| Coordinates 569510.59 E 836542.18 N | Client: Sligo County Council Client's Representative: OCS | | | |
| Method: Dynamic Probing | Elevation 6.02 mOD | Final Depth: 4.00 | Date: 23/02/2023 | Operator: JC |
| Probe Type: DPSH-B | | | | Sheet 1 of 1 Scale: 1:50 FINAL |

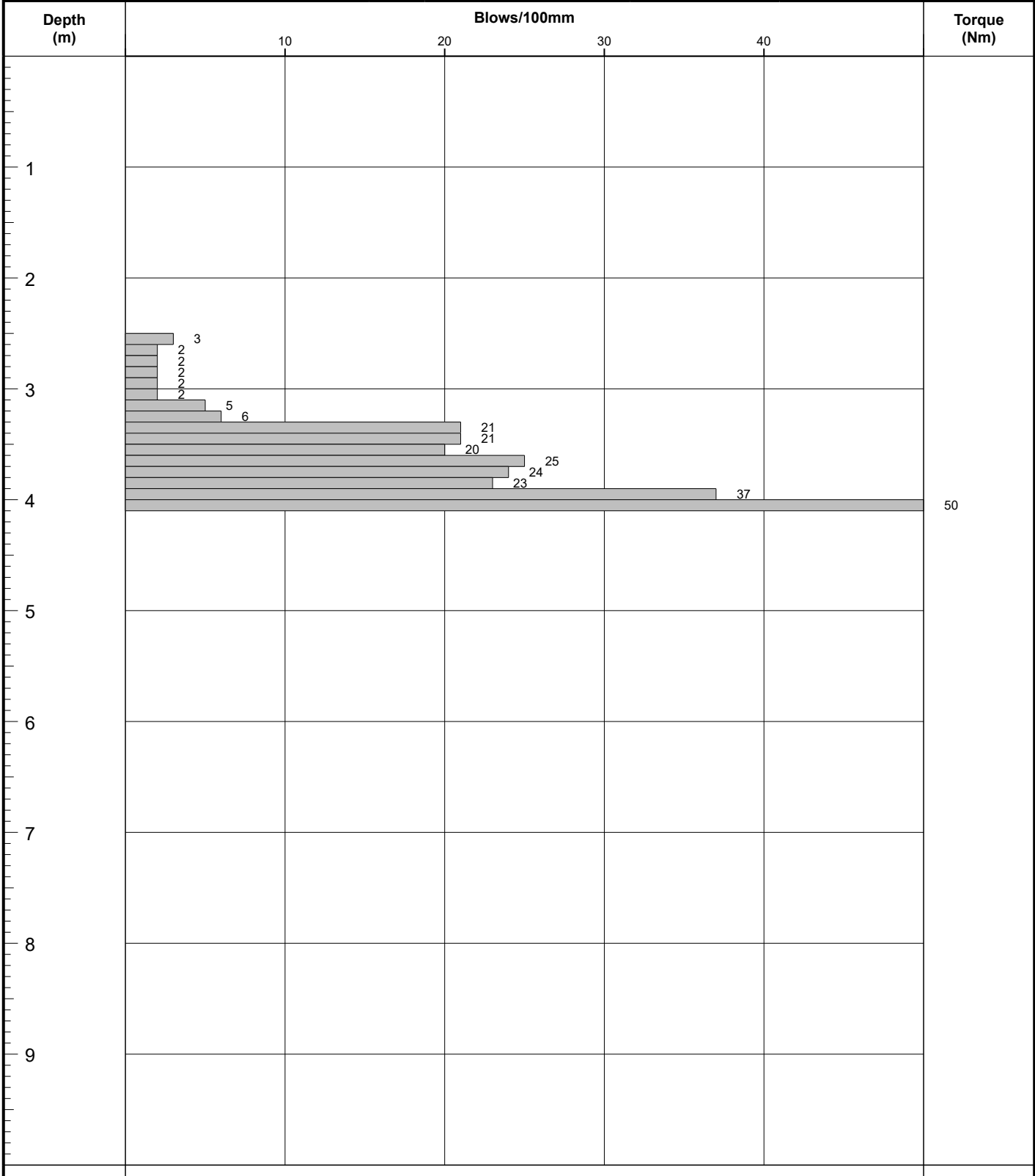

| | | | |
|---|----------------|-----------------------------------|--|
| Fall Height: 750 mm | Remarks | Last Updated 03/03/2023 | |
| Hammer Mass: 64 kg | | | |
| Cone Diameter: 51 mm | | | |
| Termination Reason Terminated on refusal. | | | |



| | | | | | | | | |
|------------------|-------------------|----------------|-----------------|----------------------------|----------------------------|-------------------------------|--------------------|-----------------------------|
| Method | Plant Used | Top (m) | Base (m) | Coordinates | Final Depth: 3.45 m | Start Date: 23/02/2023 | Driller: JC | Sheet 1 of 1 Scale: 1:50 |
| Dynamic Sampling | Dando Terrier | 0.00 | 3.45 | 569520.92 E 836539.86 N | Elevation: 6.28 mOD | End Date: 23/02/2023 | Logger: SR | FINAL |

| Depth (m) | Sample / Tests | Field Records | Casing Depth (m) | Water Depth (m) | Level mOD | Depth (m) | Legend | Description | Water | Backfill |
|-------------|----------------|--------------------------------------|------------------|-----------------|-----------|-----------|--------|---|-------|----------|
| 0.15 - 0.40 | B1 | | | | 6.13 | 0.15 | | CONCRETE | | |
| 0.40 - 1.00 | B2 | | | | 5.88 | 0.40 | | MADE GROUND: Light grey slightly sandy angular fine to coarse GRAVEL with medium cobble content. Sand is fine to coarse. Firm to stiff dark brownish grey sandy gravelly CLAY with low cobble content. Sand is fine to coarse. Gravel is angular fine to medium. | | |
| 1.00 - 3.00 | B3 | | | | | | | | | |
| 1.20 - 1.65 | SPT (C) | N=16 (2,3/4,3,4,5) Hammer SN = 1367 | 0.00 | Dry | | | | | | |
| 2.00 - 2.45 | SPT (C) | N=9 (1,1/2,2,2,3) Hammer SN = 1367 | 0.00 | Dry | | | | | | |
| 3.00 - 3.45 | SPT (C) | N=30 (3,3/5,7,8,10) Hammer SN = 1367 | 0.00 | Dry | 3.28 | 3.00 | | Stiff dark brownish grey sandy gravelly CLAY with low cobble content. Sand is fine to coarse. Gravel is angular fine to medium. | | |
| | | | | | 2.83 | 3.45 | | End of Borehole at 3.45m | | |

| Water Strikes | | | | Casing Details | | Remarks |
|---|---------------|------------|-------------|----------------|----------|--|
| Struck at (m) | Casing to (m) | Time (min) | Rose to (m) | To (m) | Diameter | |
| | | | | | | Inspection pit hand dug to 1.20m. No groundwater encountered. |
| Termination Reason | | | | | | Last Updated |
| Terminated at refusal of sampler. Continued by dynamic probe. | | | | | | 03/03/2023 |





CAUSEWAY
GEOTECH

Project No.
23-0063

Project Name:
Glenview Housing Development

Probe ID

Coordinates
569520.92 E
836539.86 N

Client:
Sligo County Council
Client's Representative:
OCS

BH04DP

Method:
Dynamic Probing

Sheet 1 of 1
Scale: 1:50

Probe Type:
DPSH-B

Elevation
6.28 mOD

Final Depth:
7.00

Date:
23/02/2023

Operator:
JC

FINAL

| Depth (m) | Blows/100mm | | | | Torque (Nm) |
|-----------|--|----------------|----|----|-------------|
| | 10 | 20 | 30 | 40 | |
| 1 | | | | | |
| 2 | | | | | |
| 3 | | | | | |
| 4 | 2, 3, 5, 8 | 10, 10, 12, 14 | | | |
| 5 | 9, 11, 12, 12, 12, 10, 12 | 11, 13, 15 | | | |
| 6 | 11, 13, 14, 14, 15, 16, 13, 15, 16, 17, 18 | 20 | 26 | 35 | |
| 7 | 50 | | | | 50 |
| 8 | | | | | |
| 9 | | | | | |

Fall Height:
750 mm
Hammer Mass:
64 kg
Cone Diameter:
51 mm

Remarks

Termination Reason
Terminated on refusal.

Last Updated
03/03/2023







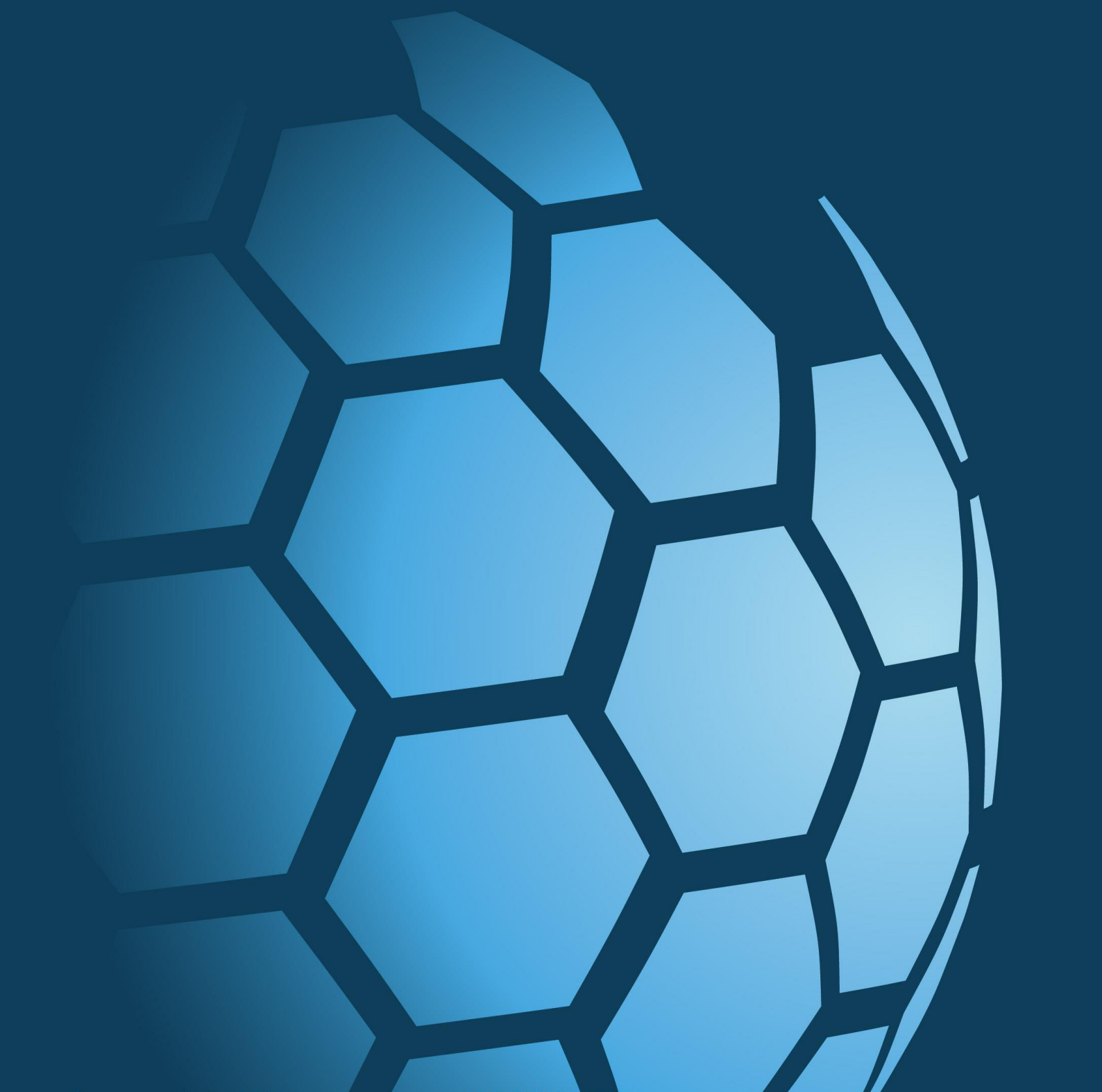

CAUSEWAY
— GEOTECH

APPENDIX C

TRIAL PIT PHOTOGRAPHS

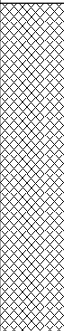

|  | | Project No. 23-0063 | Project Name: Glenview Housing Development | | Trial Pit ID TP02 | | |
|--|----------------|---|--|---------------|---|---|---|
| Method: Trial Pitting | | Coordinates 569533.08 E 836572.20 N | Client: Sligo County Council | | Client's Representative: OCS | | |
| Plant: 3t Tracked Excavator | | Elevation 5.63 mOD | Date: 01/03/2023 | Logger: RS | Sheet 1 of 1 Scale: 1:25 | | |
| Depth (m) | Sample / Tests | Field Records | Level (mOD) | Depth (m) | Legend | Description | Water |
| 1.00 - 1.00 1.00 - 1.00 | B1 D2 | | 4.53 | 1.10 |  | MADE GROUND: Soft brown slightly sandy slightly gravelly CLAY with low cobble content. Sand is fine to coarse. Gravel is subangular fine to coarse. Cobbles are angular. | 0.5 1.0 |
| 1.50 - 1.50 1.50 - 1.50 | B3 D4 | | 3.93 | 1.70 |  | Very soft dark greyish black slightly sandy slightly gravelly organic CLAY with cobble content. Sand is fine to coarse. Gravel is subangular fine to coarse. Cobbles are angular. | 1.5 |
| | | | | | | End of trial pit at 1.70m | 2.0 2.5 3.0 3.5 4.0 4.5 |
| Water Strikes Struck at (m) Remarks | | Depth: 1.70 Width: 0.35 Length: 2.00 Stability: Moderately stable | Remarks: No groundwater encountered. | | Termination Reason Terminated at refusal on boulder / possible bedrock. | | Last Updated 03/03/2023 |
| | | | | | | |  |



| | | |
|--|--|--|
| Project No. 23-0063 | Project Name: Glenview Housing Development | Trial Pit ID TP03 |
| Coordinates 569497.06 E 836551.88 N | Client: Sligo County Council | |
| Method: Trial Pitting | Client's Representative: OCS | Sheet 1 of 1 Scale: 1:25 |
| Plant: 3t Tracked Excavator | Elevation 7.50 mOD | Date: 01/03/2023 |
| | Logger: RS | FINAL |

| Depth (m) | Sample / Tests | Field Records | Level (mOD) | Depth (m) | Legend | Description | Water |
|----------------------------|----------------|---------------|-------------|-----------|--------|---|--|
| 1.00 - 1.00 1.00 - 1.00 | B1 D2 | | 6.40 | 1.10 | | MADE GROUND: Stiff light brown slightly sandy slightly gravelly CLAY with low cobble content and fragments of steel. Sand is fine to coarse. Gravel is subrounded fine to coarse. Cobbles are subrounded. | 0.5 1.0 |
| 1.50 - 1.50 1.50 - 1.50 | B3 D4 | | 5.90 | 1.60 | | MADE GROUND: Brown very gravelly very silty fine to coarse SAND. Gravel is subrounded fine to coarse. | 1.5 |
| | | | | | | End of trial pit at 1.60m | 2.0 2.5 3.0 3.5 4.0 4.5 |

| | | | |
|----------------------|---------|---|--|
| Water Strikes | | Depth: 1.60 Width: 0.35 Length: 1.75 | Remarks: No groundwater encountered. |
| Struck at (m) | Remarks | | |
| | | Stability: Unstable below | Termination Reason Terminated at maximum reach of excavator. |
| | | Last Updated 03/03/2023 | |



CAUSEWAY
— GEOTECH

APPENDIX D

TRIAL PIT PHOTOGRAPHS

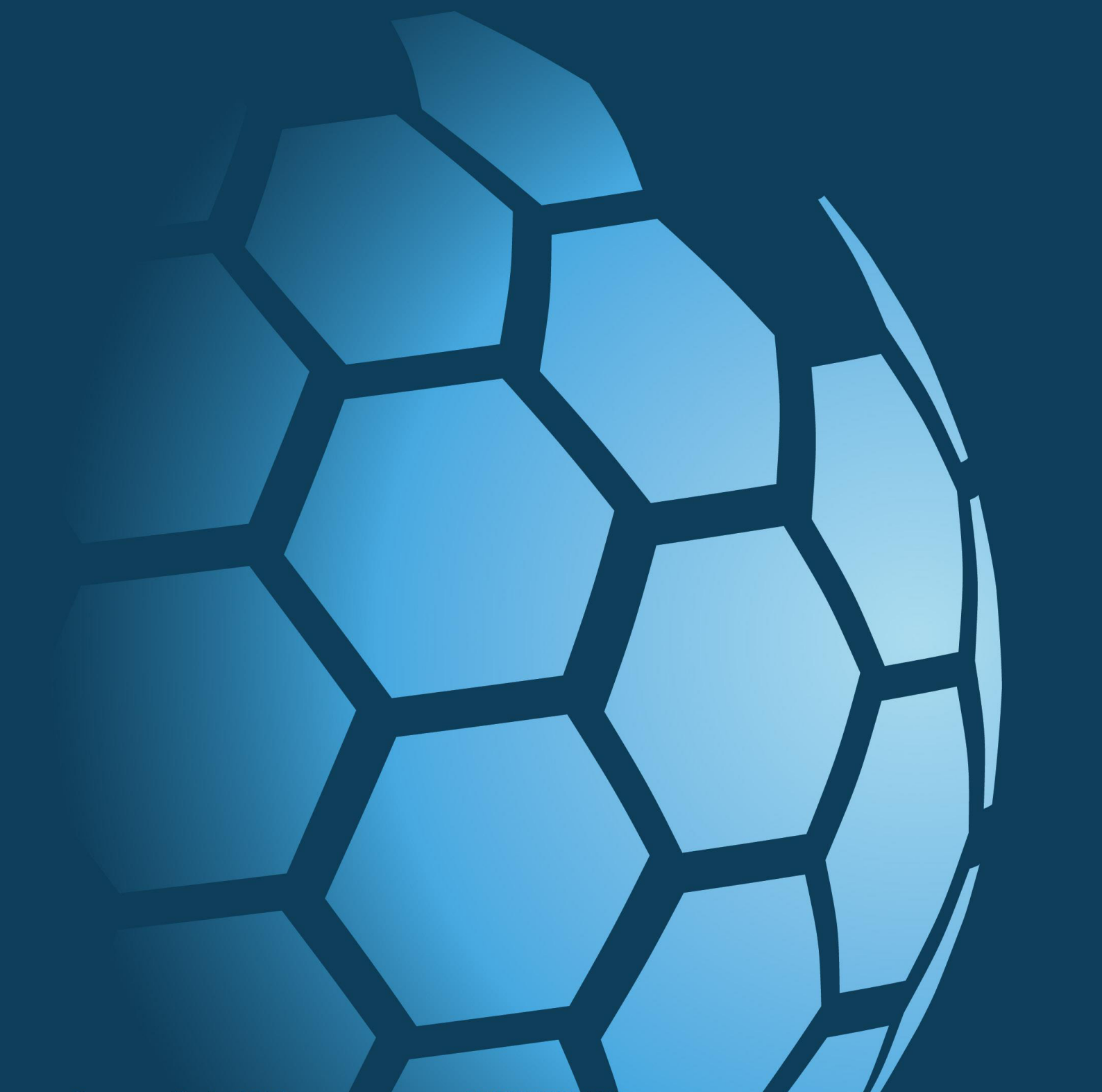



TP02



TP02



TP02



TP02



TP02



TP02



TP02



TP03



TP03



TP03



TP03



TP03



TP03



TP03



IT01



IT01



IT01



IT01



IT01



IT01



IT01



IT02



IT02



IT02



IT02



IT02



IT02



IT02



CAUSEWAY
— GEOTECH

APPENDIX E

SLIT TRENCH LOGS AND DRAWINGS

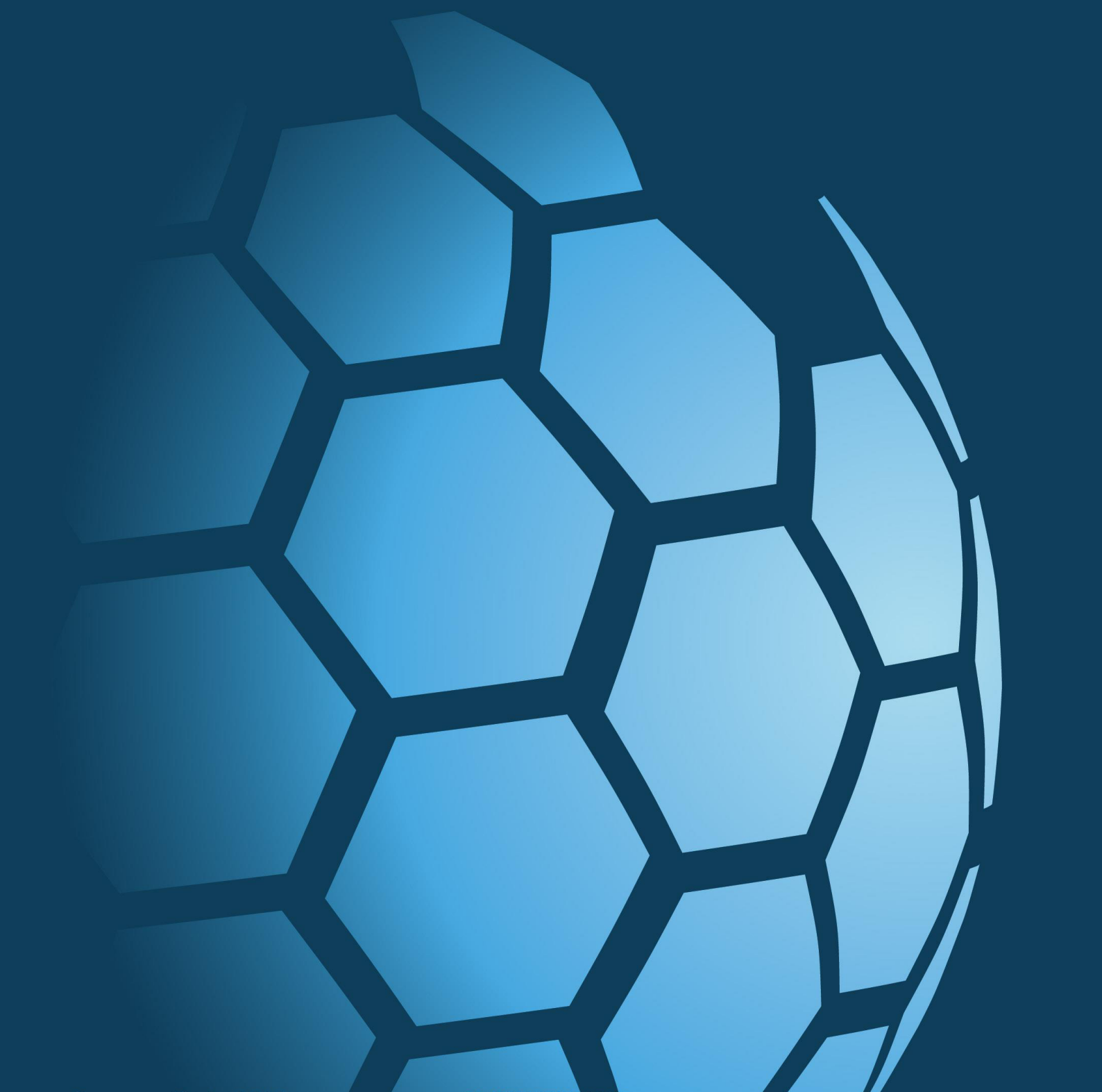



| | | |
|--|--|--|
| Project No. 23-0063 | Project Name: Glenview Housing Development | Trial Pit ID IT01 |
| Coordinates 569485.14 E 836590.96 N | Client: Sligo County Council | |
| Method: Trial Pitting | Client's Representative: OCS | Sheet 1 of 1 Scale: 1:25 |
| Plant: 3t Tracked Excavator | Elevation 3.59 mOD | Date: 01/03/2023 |
| | Logger: RS | FINAL |

| Depth (m) | Sample / Tests | Field Records | Level (mOD) | Depth (m) | Legend | Description | Water |
|-------------|----------------|---------------|-------------|-----------|--------|---|-------|
| 1.00 - 1.00 | B1 | | 2.99 | 0.60 | | MADE GROUND: Soft brown slightly sandy slightly gravelly CLAY. Sand is fine to coarse. Gravel is subrounded fine to coarse. | |
| 1.00 - 1.00 | D2 | | | | | MADE GROUND: Very soft grey slightly sandy slightly gravelly CLAY with rare fragments of red brick . Sand is fine to coarse. Gravel is subrounded fine to coarse. | |
| | | | 2.39 | 1.20 | | End of trial pit at 1.20m | |

| | | | |
|----------------------|---------|---|---|
| Water Strikes | | Depth: 1.20 Width: 0.35 Length: 1.30 | Remarks: No groundwater encountered. |
| Struck at (m) | Remarks | | |
| | | Stability: Moderately stable | Termination Reason Terminated at scheduled depth. |
| | | Last Updated 03/03/2023 | |



| | | |
|--|--|---------------------------------|
| Project No. 23-0063 | Project Name: Glenview Housing Development | Trial Pit ID IT02 |
| Coordinates 569488.75 E 836584.53 N | Client: Sligo County Council | |
| Method: Trial Pitting | Client's Representative: OCS | Sheet 1 of 1 Scale: 1:25 |
| Plant: 3t Tracked Excavator | Elevation 4.05 mOD | Date: 01/03/2023 |
| | Logger: RS | FINAL |

| Depth (m) | Sample / Tests | Field Records | Level (mOD) | Depth (m) | Legend | Description | Water |
|-------------|----------------|----------------------|-------------|-----------|--------|---|-------|
| 1.00 - 1.00 | B1 | Medium flow at 0.65m | 3.65 | 0.40 | | MADE GROUND: Soft brown slightly sandy slightly gravelly CLAY. Sand is fine to coarse. Gravel is subrounded fine to coarse. | ▼ |
| 1.00 - 1.00 | D2 | | 2.85 | 1.20 | | MADE GROUND: Grey very sandy very silty subrounded fine to coarse GRAVEL with high cobble content. Sand is fine to coarse. Cobbles are subrounded | |
| | | | | | | End of trial pit at 1.20m | |

| | | | |
|----------------------|----------------------|---|---|
| Water Strikes | | Depth: 1.20 Width: 0.50 Length: 1.10 | Remarks: |
| Struck at (m) | Remarks | | |
| 0.65 | Medium flow at 0.65m | Stability: Unstable | Termination Reason Terminated at scheduled depth. |
| | | | Last Updated 03/03/2023 |



JOB NUMBER: 23-0063 JOB NAME: Glenview Housing Development LOCATION: ST01

CLIENT: Sligo County Council CLIENTS REPRESENTATIVE: OCSC CREW: RS PLANT & EQUIPMENT: 3 Tonne Excavator & Hand Tools

TRENCH: (SECTION & PLAN)

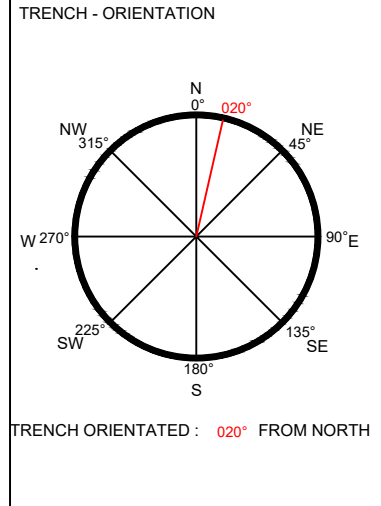
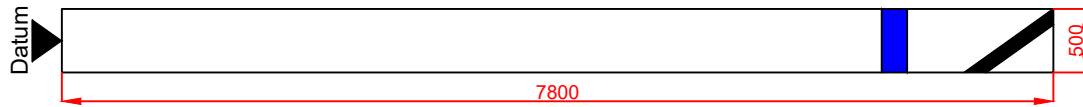
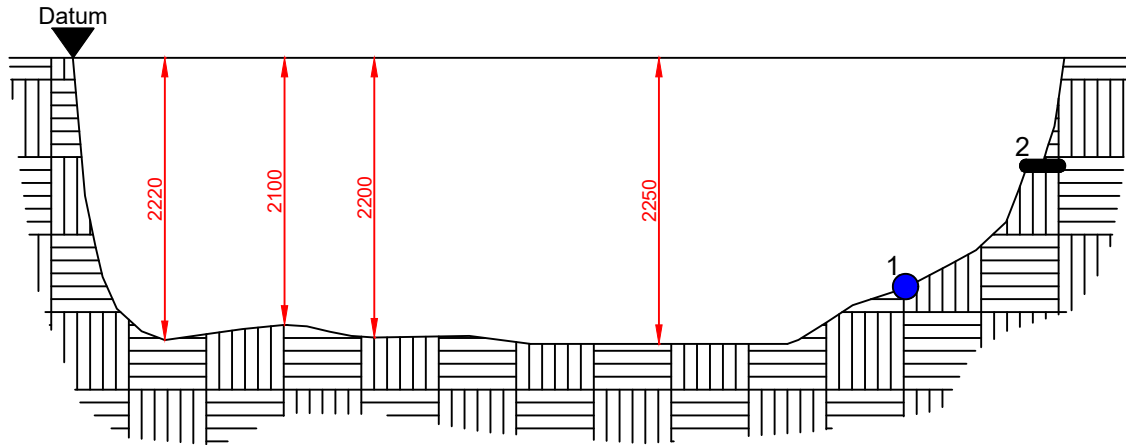

COORDINATES: DATUM
 EASTING: 569504.46
 NORTHING: 836582.69
 ELEVATION: 4.68

TRENCH LENGTH (m) : 7.80
 TRENCH DEPTH (m) : 2.25
 TRENCH WIDTH (m) : 0.50

STABILITY: STABLE
 GROUNDWATER: NONE

SCALE: NTS@A3
 DRAWN: BS
 CHECKED: SR
 DATE EXCAVATED: 01/03/2023

| No: | Type of Service: | Diameter (in mm) | Depth to Top of Service (m) | Distance to Centre of Service (m) | Details/Comments |
|-----|------------------|------------------|-----------------------------|-----------------------------------|----------------------|
| 01 | Unknown | 200 | 1.70 | 6.55 | 200mm Blue PVC Pipe |
| 02 | Unknown | 100 | 0.80 | 7.50 | 100mm Black PVC Pipe |
| 03 | | | | | |
| 04 | | | | | |
| 05 | | | | | |
| 06 | | | | | |
| 07 | | | | | |
| 08 | | | | | |
| 09 | | | | | |
| 10 | | | | | |
| 11 | | | | | |
| 12 | | | | | |
| 13 | | | | | |
| 14 | | | | | |
| 15 | | | | | |





CAUSEWAY
— GEOTECH

APPENDIX F

SLIT TRENCH PHOTOGRAPHS

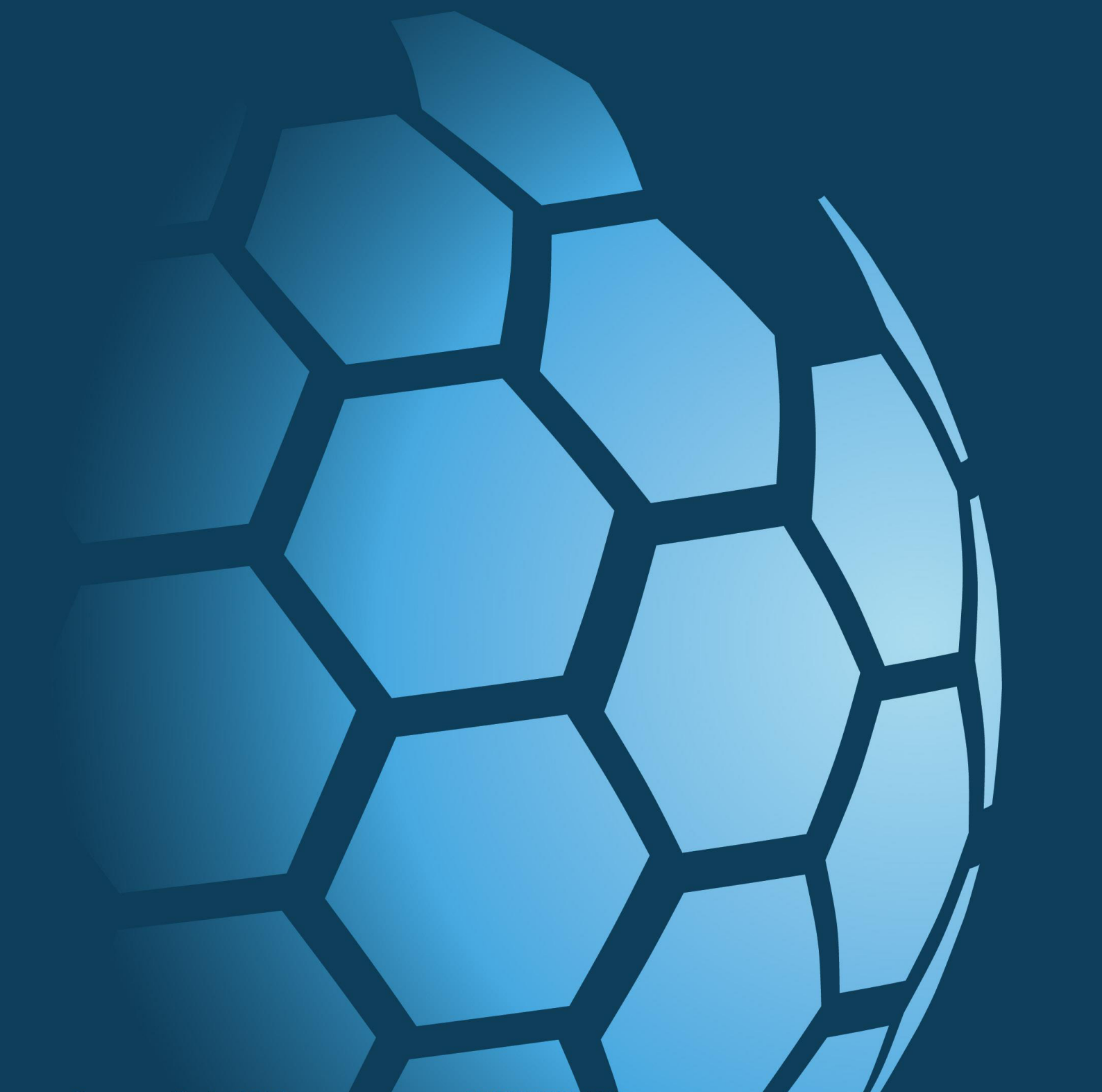



ST01



ST01



ST01



ST01



ST01



ST01



ST01



ST01



ST01



ST01



ST01



ST01



CAUSEWAY
— GEOTECH

APPENDIX G

SOAKAWAY TEST RESULTS

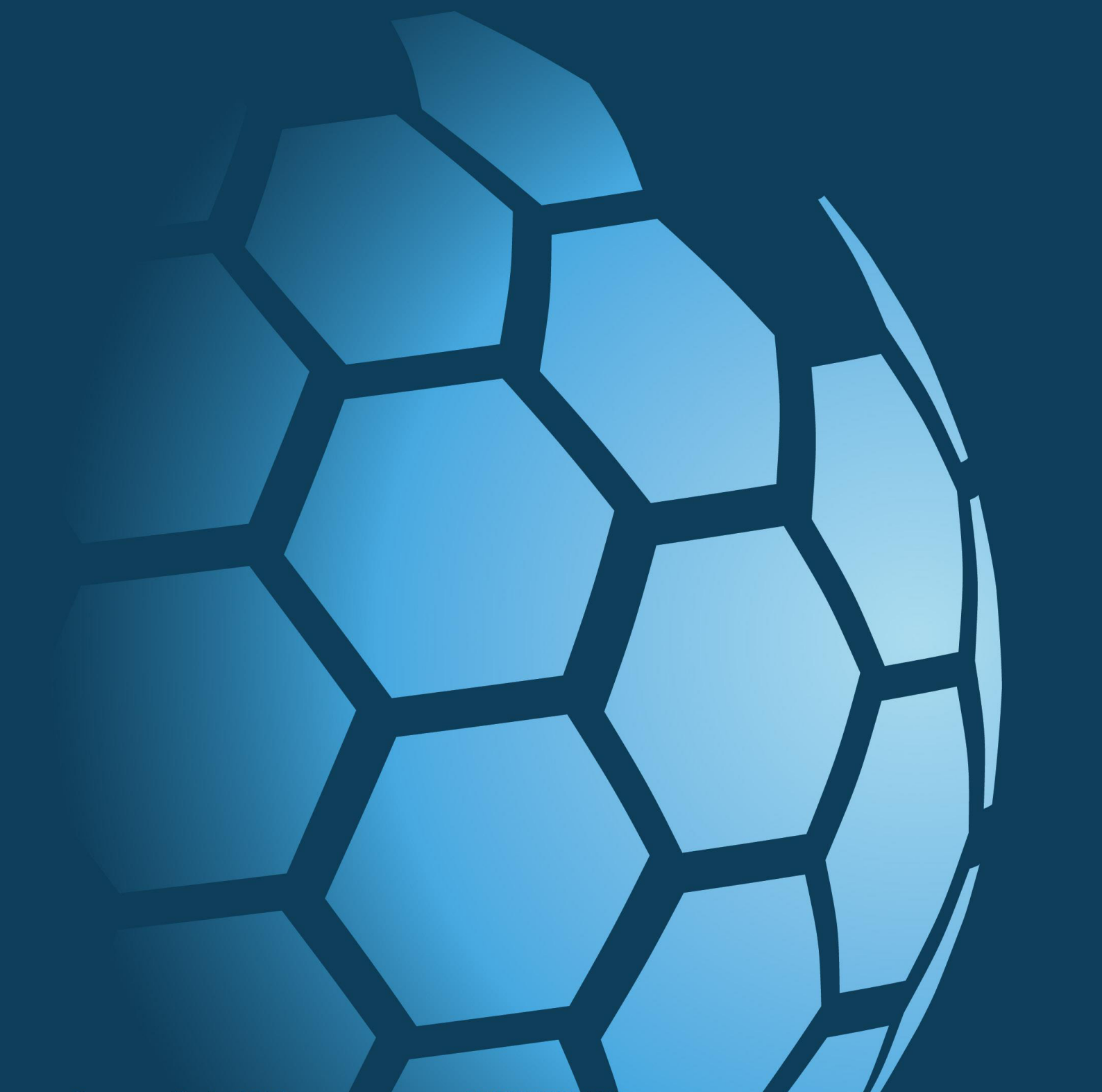



| | | |
|--|--|--|
| Project No. 23-0063 | Project Name: Glenview Housing Development | Trial Pit ID IT01 |
| Coordinates 569485.14 E 836590.96 N | Client: Sligo County Council | |
| Method: Trial Pitting | Client's Representative: OCS | Sheet 1 of 1 Scale: 1:25 |
| Plant: 3t Tracked Excavator | Elevation 3.59 mOD | Date: 01/03/2023 |
| | Logger: RS | FINAL |

| Depth (m) | Sample / Tests | Field Records | Level (mOD) | Depth (m) | Legend | Description | Water |
|-------------|----------------|---------------|-------------|-----------|--------|---|-------|
| 1.00 - 1.00 | B1 | | 2.99 | 0.60 | | MADE GROUND: Soft brown slightly sandy slightly gravelly CLAY. Sand is fine to coarse. Gravel is subrounded fine to coarse. | |
| 1.00 - 1.00 | D2 | | 2.39 | 1.20 | | MADE GROUND: Very soft grey slightly sandy slightly gravelly CLAY with rare fragments of red brick . Sand is fine to coarse. Gravel is subrounded fine to coarse. | |
| | | | | | | End of trial pit at 1.20m | |

| | | | |
|----------------------|---------|---|---|
| Water Strikes | | Depth: 1.20 Width: 0.35 Length: 1.30 | Remarks: No groundwater encountered. |
| Struck at (m) | Remarks | | |
| | | Stability: Moderately stable | Termination Reason Terminated at scheduled depth. |
| | | Last Updated 03/03/2023 | |

Soakaway Infiltration Test

Project No.: 23-0063
Site: Glenview Housing Development
Test Location: IT01
Test Date: 01 March 2023



*Analysis using method as described in BRE Digest 365
and CIRIA Report C697-The SUDS Manual*

width (m) length (m)
test pit top dimensions 0.35 1.30
test pit base dimensions 0.30 0.35
test pit depth (m) 1.20

depth to groundwater before adding water (m) = Dry

| time (mins) | depth to water surface (m) | depth of water in pit (m) |
|-------------|----------------------------|---------------------------|
| 0 | 0.00 | 1.20 |
| 0.5 | 0.01 | 1.19 |
| 1 | 0.01 | 1.19 |
| 2 | 0.01 | 1.19 |
| 4 | 0.02 | 1.18 |
| 6 | 0.02 | 1.18 |
| 8 | 0.02 | 1.18 |
| 10 | 0.02 | 1.18 |
| 15 | 0.02 | 1.18 |
| 20 | 0.02 | 1.18 |
| 25 | 0.02 | 1.18 |
| 30 | 0.02 | 1.18 |
| 45 | 0.02 | 1.18 |
| 60 | 0.02 | 1.18 |
| 90 | 0.03 | 1.18 |
| 180 | 0.03 | 1.18 |
| 225 | 0.03 | 1.18 |
| 255 | 0.03 | 1.17 |
| 275 | 0.03 | 1.17 |

From graph below:
test start - 75% depth at
 0.9 m water depth
 time is not determined

test end - 25% depth at
 0.3 m water depth
 time is not determined

infiltration rate (q) is very low

| time (mins) | depth to water (m) | depth of water in pit (m) | time elapsed (mins) | volume of water lost (m ³) | Area of walls and base at 50% drop (m ²) | q (m/min) | q (m/h) |
|-------------|--------------------|---------------------------|---------------------|--|--|-----------|---------|
| | 0.30 | 0.9 | | | | | |
| | 0.90 | 0.3 | | | | | |

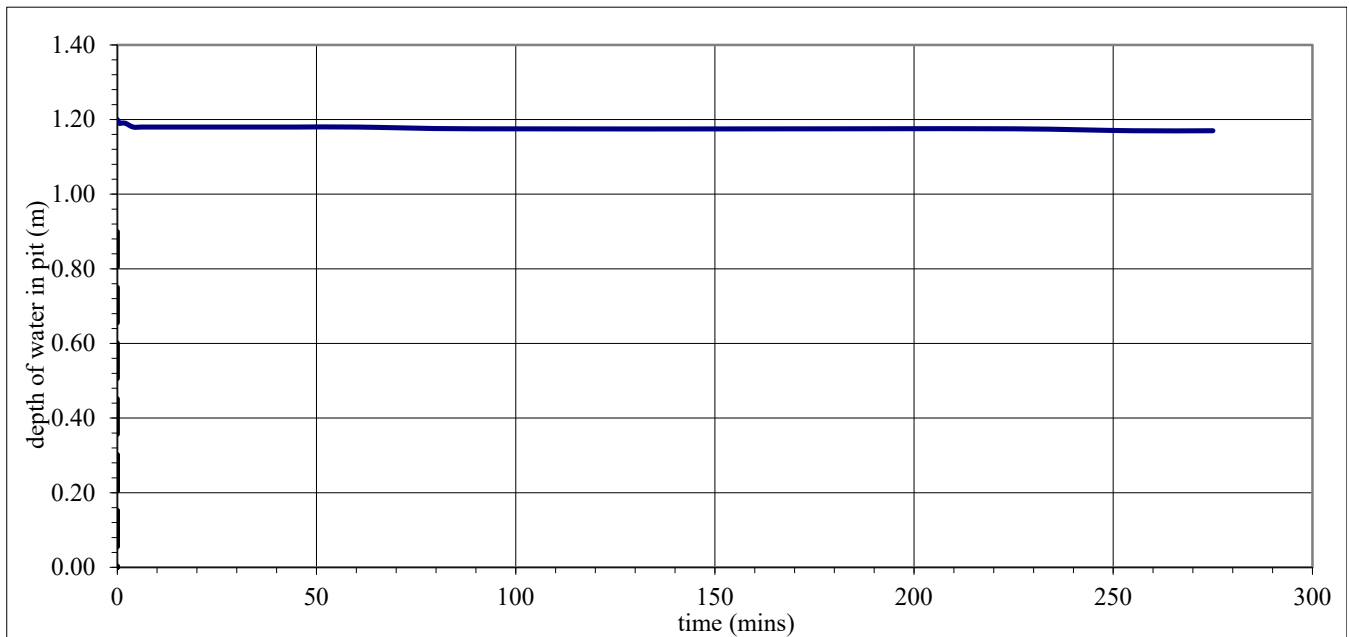



| | | |
|--|--|---------------------------------|
| Project No. 23-0063 | Project Name: Glenview Housing Development | Trial Pit ID IT02 |
| Coordinates 569488.75 E 836584.53 N | Client: Sligo County Council | |
| Method: Trial Pitting | Client's Representative: OCS | Sheet 1 of 1 Scale: 1:25 |
| Plant: 3t Tracked Excavator | Elevation 4.05 mOD | Date: 01/03/2023 |
| | | Logger: RS |
| | | FINAL |

| Depth (m) | Sample / Tests | Field Records | Level (mOD) | Depth (m) | Legend | Description | Water |
|----------------------------|----------------|----------------------|-------------|-----------|--------|---|-------|
| 1.00 - 1.00 1.00 - 1.00 | B1 D2 | Medium flow at 0.65m | 3.65 | 0.40 | | MADE GROUND: Soft brown slightly sandy slightly gravelly CLAY. Sand is fine to coarse. Gravel is subrounded fine to coarse. | |
| | | | | | | MADE GROUND: Grey very sandy very silty subrounded fine to coarse GRAVEL with high cobble content. Sand is fine to coarse. Cobbles are subrounded | ▼ |
| | | | 2.85 | 1.20 | | End of trial pit at 1.20m | |

| | | | |
|-------------------------------|----------------------|---|-----------------------------------|
| Water Strikes | | Depth: 1.20 Width: 0.50 Length: 1.10 | Remarks: |
| Struck at (m) | Remarks | | |
| 0.65 | Medium flow at 0.65m | | |
| Stability: Unstable | | Termination Reason Terminated at scheduled depth. | Last Updated 03/03/2023 |



Soakaway Infiltration Test

Project No.: 23-0063
Site: Glenview Housing Development
Test Location: IT02
Test Date: 01 March 2023



Analysis using method as described in BRE Digest 365 and CIRIA Report C697-The SUDS Manual

width (m) length (m)
 test pit top dimensions 0.50 1.10
 test pit base dimensions 0.50 0.50
 test pit depth (m) 0.65

depth to groundwater before adding water (m) = 0.65

| time (mins) | depth to water surface (m) | depth of water in pit (m) |
|-------------|----------------------------|---------------------------|
| 0 | 0.10 | 0.56 |
| 0.5 | 0.10 | 0.55 |
| 1 | 0.11 | 0.55 |
| 2 | 0.11 | 0.54 |
| 4 | 0.12 | 0.53 |
| 6 | 0.13 | 0.52 |
| 8 | 0.14 | 0.51 |
| 10 | 0.15 | 0.51 |
| 15 | 0.15 | 0.50 |
| 20 | 0.16 | 0.49 |
| 25 | 0.17 | 0.48 |
| 30 | 0.17 | 0.48 |
| 45 | 0.18 | 0.47 |
| 60 | 0.19 | 0.46 |
| 105 | 0.21 | 0.45 |
| 180 | 0.23 | 0.42 |
| 240 | 0.24 | 0.41 |
| 260 | 0.25 | 0.41 |
| 285 | 0.25 | 0.40 |

From graph below:

test start - 75% depth at
 0.41625 m water depth
 time is not determined

test end - 25% depth at
 0.13875 m water depth
 time is not determined

infiltration rate (q) is very low

| time (mins) | depth to water (m) | depth of water in pit (m) | time elapsed (mins) | volume of water lost (m ³) | Area of walls and base at 50% drop (m ²) | q (m/min) | q (m/h) |
|-------------|--------------------|---------------------------|---------------------|--|--|-----------|---------|
| | 0.23 | 0.41625 | | | | | |
| | 0.51 | 0.13875 | | | | | |

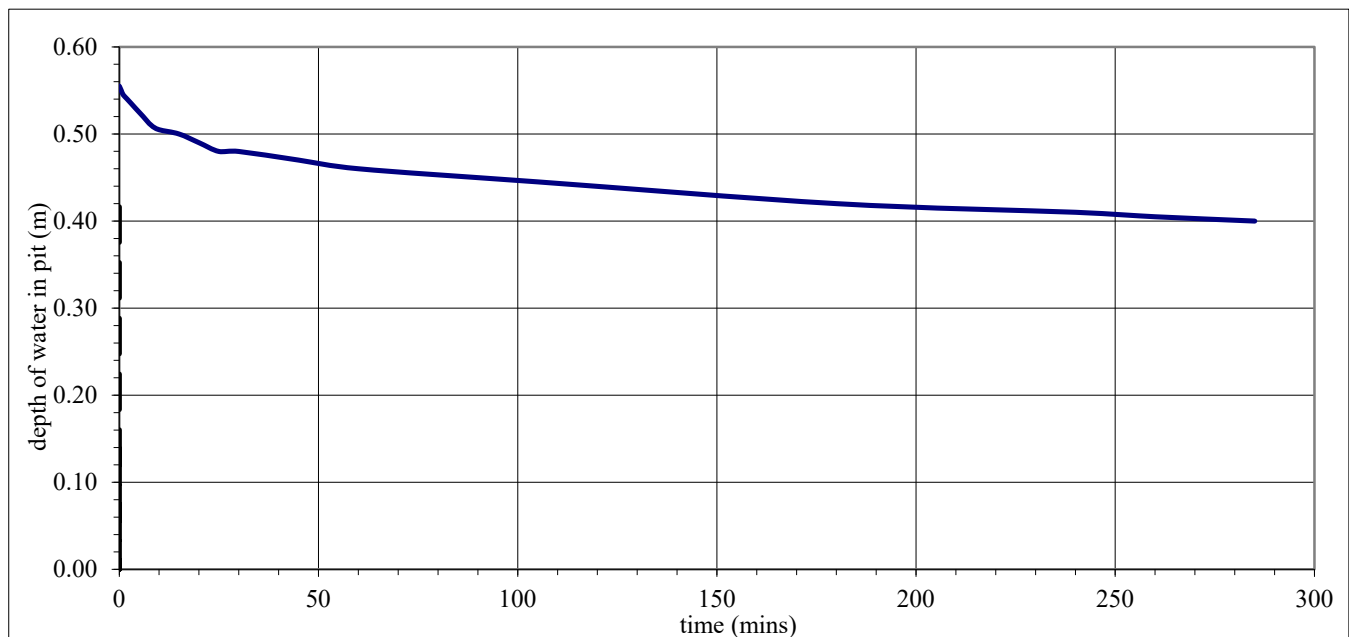



CAUSEWAY
— GEOTECH

APPENDIX H
INDIRECT IN-SITU CBR TESTS

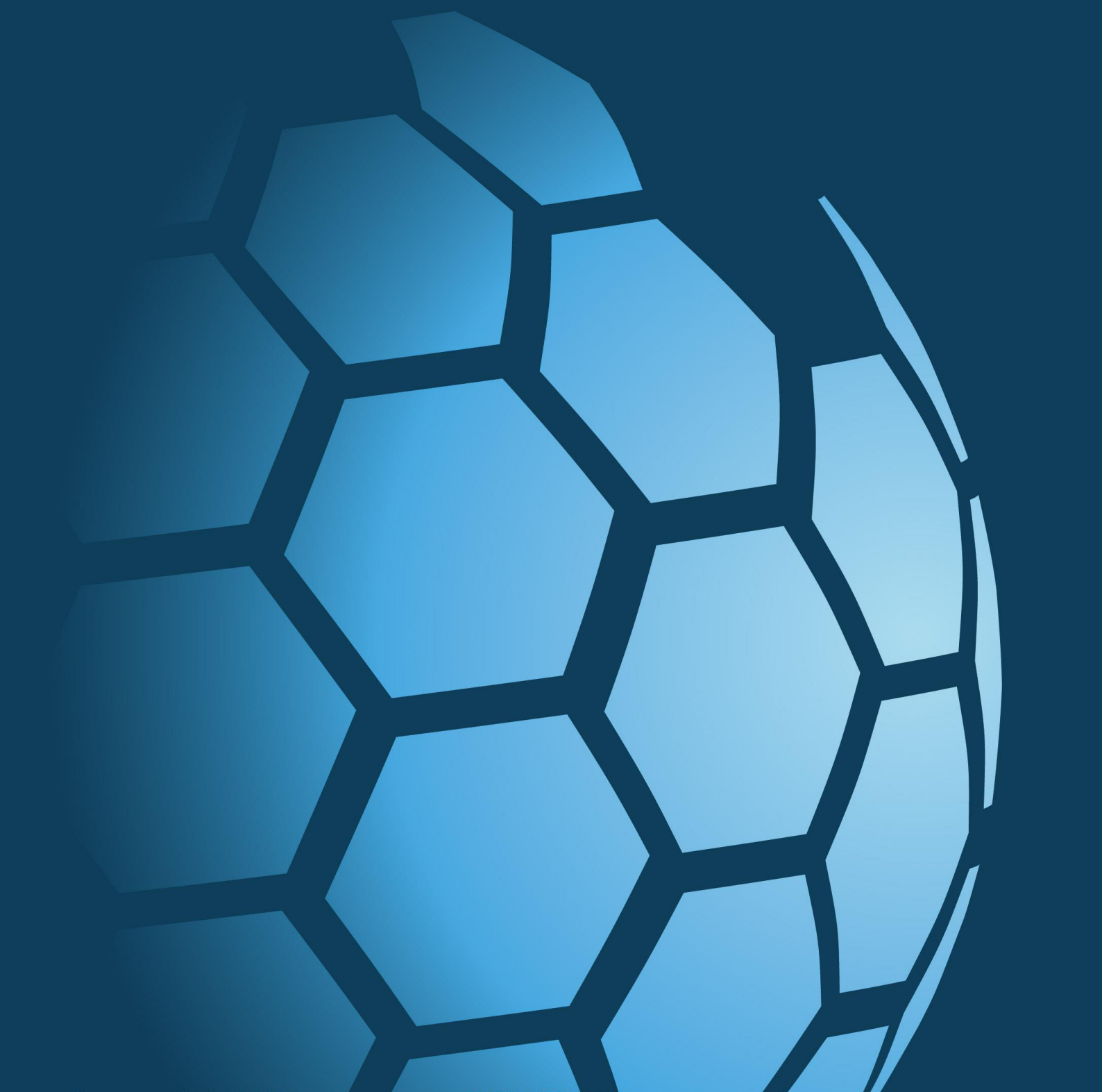

Dynamic Cone Penetrometer (DCP) test results and estimated CBR

| | |
|-----------------------|------------------------------|
| Project Number | 23-0063 |
| Project Name | Glenview Housing Development |
| Site Location | TP02 |



| | |
|----------------------|------|
| Test Number | 1 |
| Depth bgl (m) | 0.20 |

| | |
|--------------------|------------|
| Date Tested | 01/03/2023 |
| Weather | Dry |

Test conducted in accordance with Documented In-House Technical Procedure IMS TP7-4 and DMRB CS 229 Rev 0
 CBR calculated using the TRRL CBR DCP relationship: $\log_{10}(\text{CBR}) = 2.48 - 1.057 \times \log_{10}(\text{mm/blow})$ in accordance with DMRB CS 229 Rev 0

| | |
|----------------------------|---|
| Surface preparation | Description of surface material at test depth |
| Dug Down | Slightly sandy slightly gravelly CLAY with low cobble content |

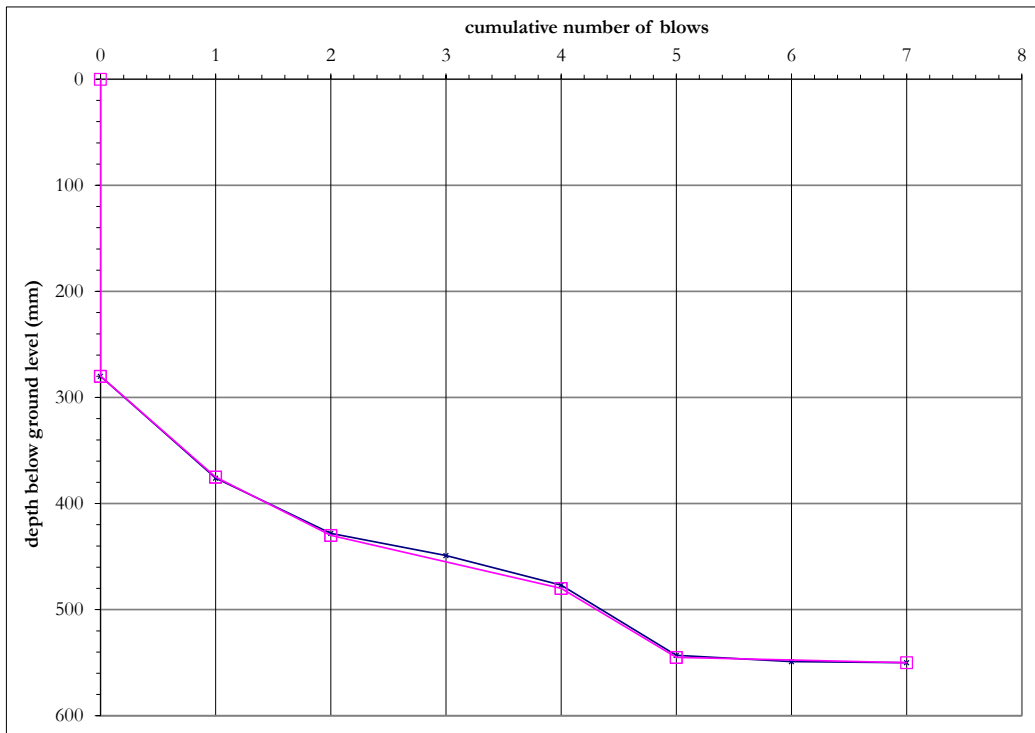

| top / base of layer (mm) | mm/blow | CBR (%) |
|--------------------------|---------|---------|
| 0 | N/A | N/A |
| 280 | | |
| 280 | 95 | 2.5 |
| 375 | | |
| 375 | 55 | 4.4 |
| 430 | | |
| 430 | 25 | 10 |
| 480 | | |
| 480 | 65 | 3.7 |
| 545 | | |
| 545 | 2.5 | >100 |
| 550 | | |

| | |
|---|---|
| CBR Range Min: 2.5 Max: >100 | The self-weight penetration at the start of the test (shown above) has not been included in the minimum and maximum values shown to the left. The selection of layers is based on visual interpretation of the data. The insitu DCP reading (mm/blow) and CBR values are valid at the time of testing; variation in moisture content or other factors may affect the insitu value. Opinions and interpretations expressed herein are outside the scope of UKAS accreditation. This report should not be reproduced except in full without the written approval of the laboratory. |
|---|---|

| | |
|---|------|
| Deviation(s) from standard procedure | None |
|---|------|

| | |
|----------------------------------|--|
| Observations and comments | |
|----------------------------------|--|

| Approved Name and Appointment | | |
|-------------------------------|--|------------|
| Darren O'Mahony Director | | March 2023 |



Dynamic Cone Penetrometer (DCP) test results and estimated CBR

| | |
|-----------------------|------------------------------|
| Project Number | 23-0063 |
| Project Name | Glenview Housing Development |
| Site Location | TP02 |



| | |
|----------------------|------|
| Test Number | 2 |
| Depth bgl (m) | 0.20 |

| | |
|--------------------|------------|
| Date Tested | 01/03/2023 |
| Weather | Dry |

Test conducted in accordance with Documented In-House Technical Procedure IMS TP7-4 and DMRB CS 229 Rev 0
 CBR calculated using the TRRL CBR DCP relationship: $\log_{10}(\text{CBR}) = 2.48 - 1.057 \times \log_{10}(\text{mm/blow})$ in accordance with DMRB CS 229 Rev 0

| | |
|----------------------------|---|
| Surface preparation | Description of surface material at test depth |
| Dug Down | Slightly sandy slightly gravelly CLAY with low cobble content |

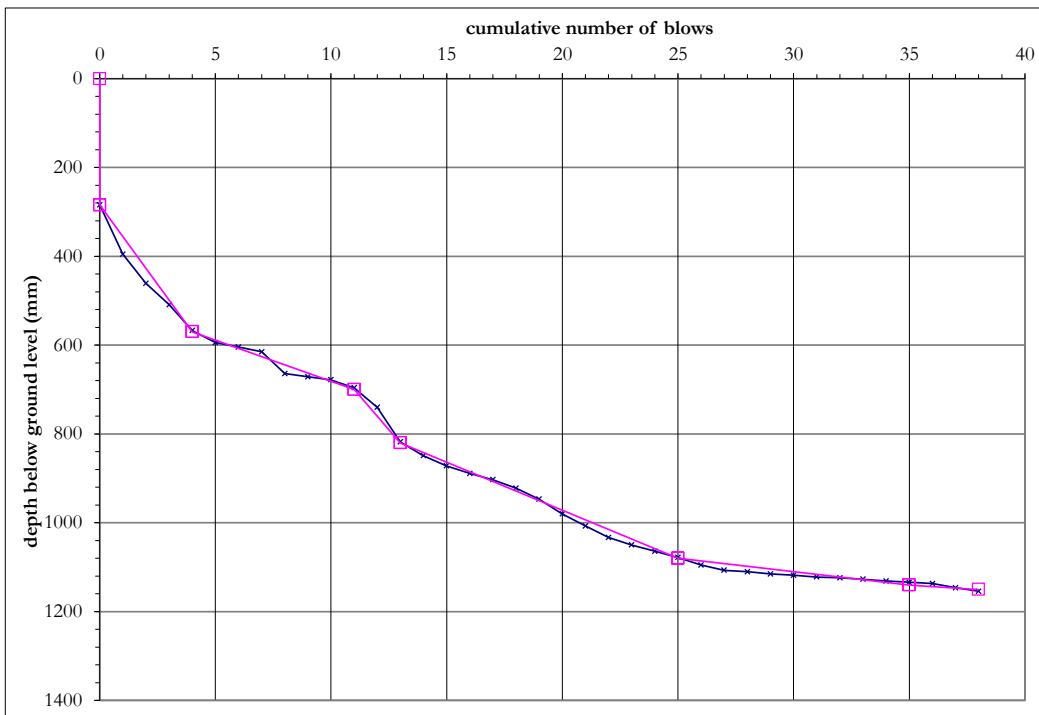

| top / base of layer (mm) | mm/blow | CBR (%) |
|--------------------------|---------|---------|
| 0 | N/A | N/A |
| 284 | | |
| 284 | 72 | 3.3 |
| 570 | | |
| 570 | 19 | 14 |
| 700 | | |
| 700 | 60 | 4 |
| 820 | | |
| 820 | 22 | 12 |
| 1080 | | |
| 1080 | 6 | 45 |
| 1140 | | |
| 1140 | 3.3 | 85 |
| 1150 | | |
| | | |
| | | |
| | | |
| | | |

| | | |
|------------------|---------------------|---|
| CBR Range | Min: 3.3 Max: 85 | The self-weight penetration at the start of the test (shown above) has not been included in the minimum and maximum values shown to the left. The selection of layers is based on visual interpretation of the data. The insitu DCP reading (mm/blow) and CBR values are valid at the time of testing; variation in moisture content or other factors may affect the insitu value. Opinions and interpretations expressed herein are outside the scope of UKAS accreditation. This report should not be reproduced except in full without the written approval of the laboratory. |
|------------------|---------------------|---|

| | |
|---|------|
| Deviation(s) from standard procedure | None |
|---|------|

| | |
|----------------------------------|--|
| Observations and comments | |
|----------------------------------|--|

| Approved Name and Appointment | | |
|-------------------------------|--|------------|
| Darren O'Mahony Director | | March 2023 |





CAUSEWAY
— GEOTECH

APPENDIX I

SPT HAMMER ENERGY MEASUREMENT REPORT

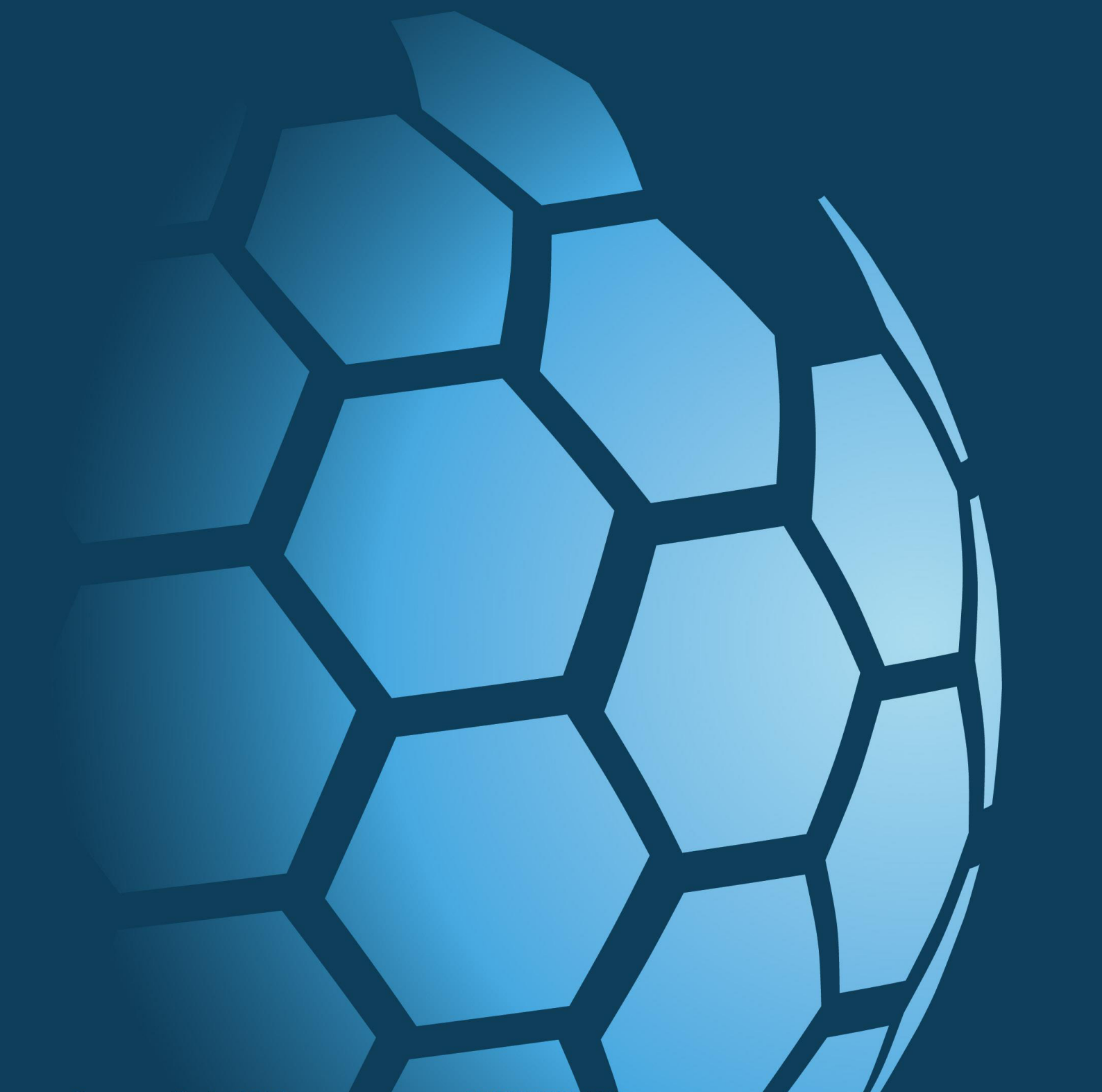

Southern Testing
Unit 11
Charlwoods Road
East Grinstead
West Sussex
RH19 2HU

SPT Hammer Ref: T8
Test Date: 12/02/2022
Report Date: 14/02/2022
File Name: T8.spt
Test Operator: NPB

Instrumented Rod Data

Diameter d_r (mm): 54
Wall Thickness t_r (mm): 6.0
Assumed Modulus E_a (GPa): 200
Accelerometer No.1: 64786
Accelerometer No.2: 64789

SPT Hammer Information

Hammer Mass m (kg): 63.0
Falling Height h (mm): 760
SPT String Length L (m): 12.0

Comments / Location

CAUSEWAY

*Asset No
1367.*

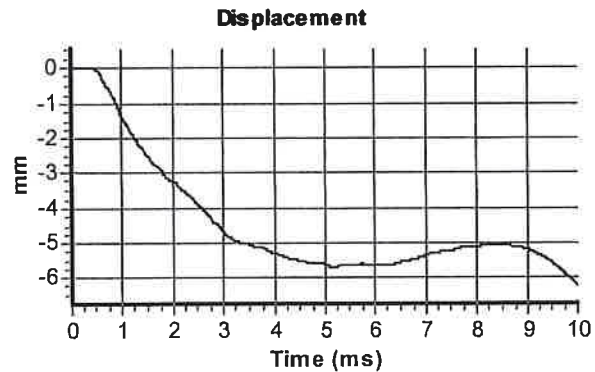
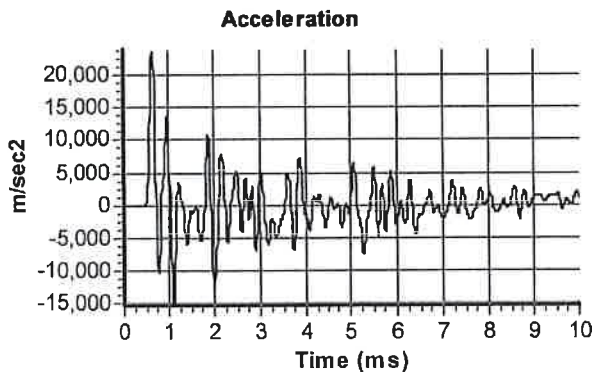
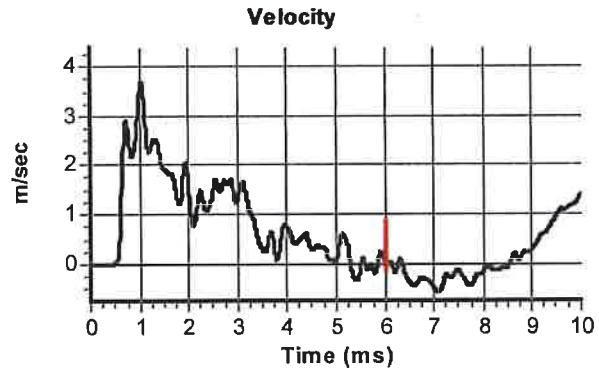
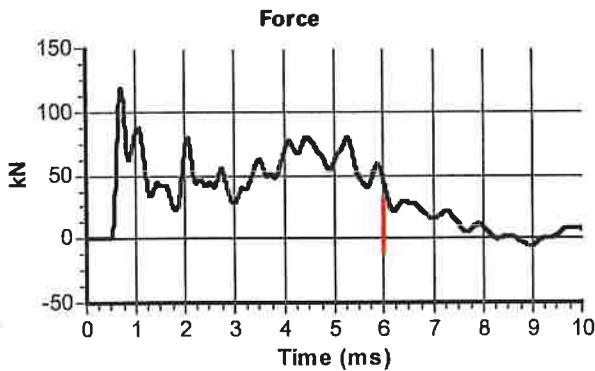

Calculations

Area of Rod A_r (mm²): 905
Theoretical Energy E_{theor} (J): 473
Measured Energy E_{meas} (J): 336

Energy Ratio E_r (%): **71**

NPB Burrows

Signed: N Burrows
Title: FOC Manager

The recommended calibration interval is 12 months



CAUSEWAY
— GEOTECH

APPENDIX J
GPR SURVEY

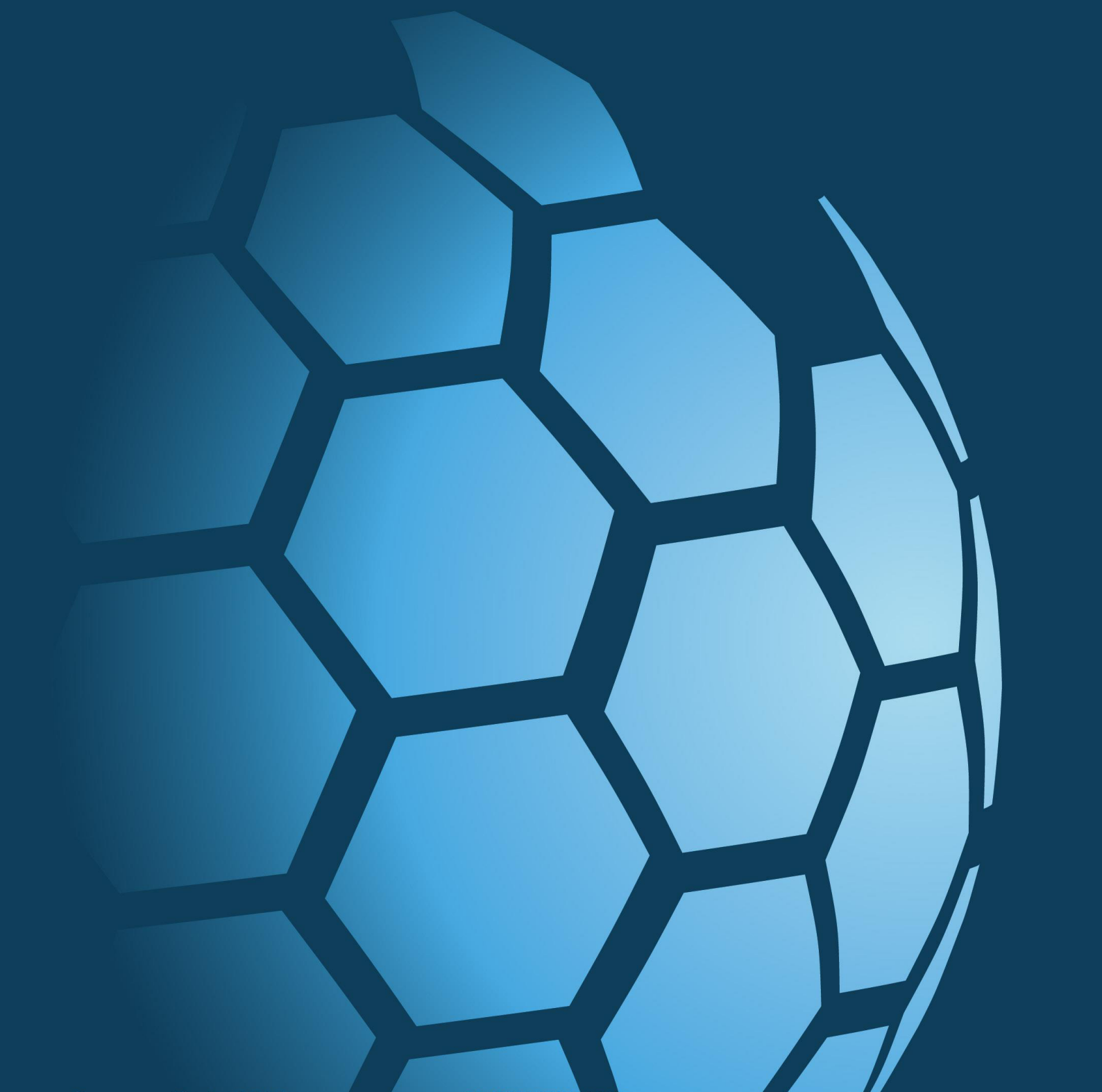

LEGEND

| DESCRIPTION | COLOUR | TRACED SERVICES | INFERRED SERVICES |
|--|-------------|-----------------|-------------------|
| Foul Water Sewer | GREEN | | |
| Surface/Storm Water Sewer | CYAN | | |
| Combined Sewer | BROWN | | |
| Power | RED | | |
| Telecoms | MAGENTA | | |
| Cable TV | PURPLE | | |
| Alternative Telecoms | PINK | | |
| Watermain | BLUE | | |
| Gas | YELLOW | | |
| Unknown Service/Anomaly | ORANGE | | |
| Trench Scar | LIGHT GREEN | | |
| Utility Providers Records | | | |
| ESB Records | RED | | |
| Bord Gais Records | YELLOW | | |
| Telecom Records | MAGENTA | | |
| Water Records | BLUE | | |
| Foul Sewer/Water Manhole | GREEN | | |
| Surface/Storm Water Manhole | CYAN | | |
| Power Manhole | RED | | |
| Telecom Manhole | MAGENTA | | |
| Watermain Manhole | BLUE | | |
| Water Hydrant, Meter, Sluice Valve, Air Valve, Stop Cock | BLUE | | |
| Gas Line Manhole | YELLOW | | |
| Foul Sewer/Water Gully | GREEN | | |
| Surface/Storm Water Gully | CYAN | | |

NOTES:

- Utility survey carried out with RF & GPR equipment.
- RF = RD8000 Transmitter & Receiver.
- UTT denotes unable to Trace, UTO denotes unable to Open
- GPR = Ground Penetrating Radar - Mala 100 Mhz, 250 Mhz & 500 Mhz.
- Unknown voltage on electric cables.
- Dia. 300mm denotes the diameter of the pipe.
- 0.5 denotes depth in metres below ground level to top of pipe.
- Survey carried out in February 2023.
- R denotes sections of services taken from records.
- D = Depth to Pipe, DTF = Depth to Floor, DTS = Depth to Silt, BOC = Bottom Of Chamber.
- Where Invert Levels are shown adjacent to MH's, IC's etc. are to the Invert of the lowest pipe/duct within the manhole. There may be further pipes/ducts within the MH which are located closer to ground level as per the depths marked on individual pipes/ducts. Care should be taken as higher level ducts may contain live electrical cables.

Disclaimer:
The information on this drawing is a general guide only and the accuracy thereof cannot be guaranteed. No liability is accepted for any discrepancy, omission or deviation from the actual subsurface location or depth to underground utilities.

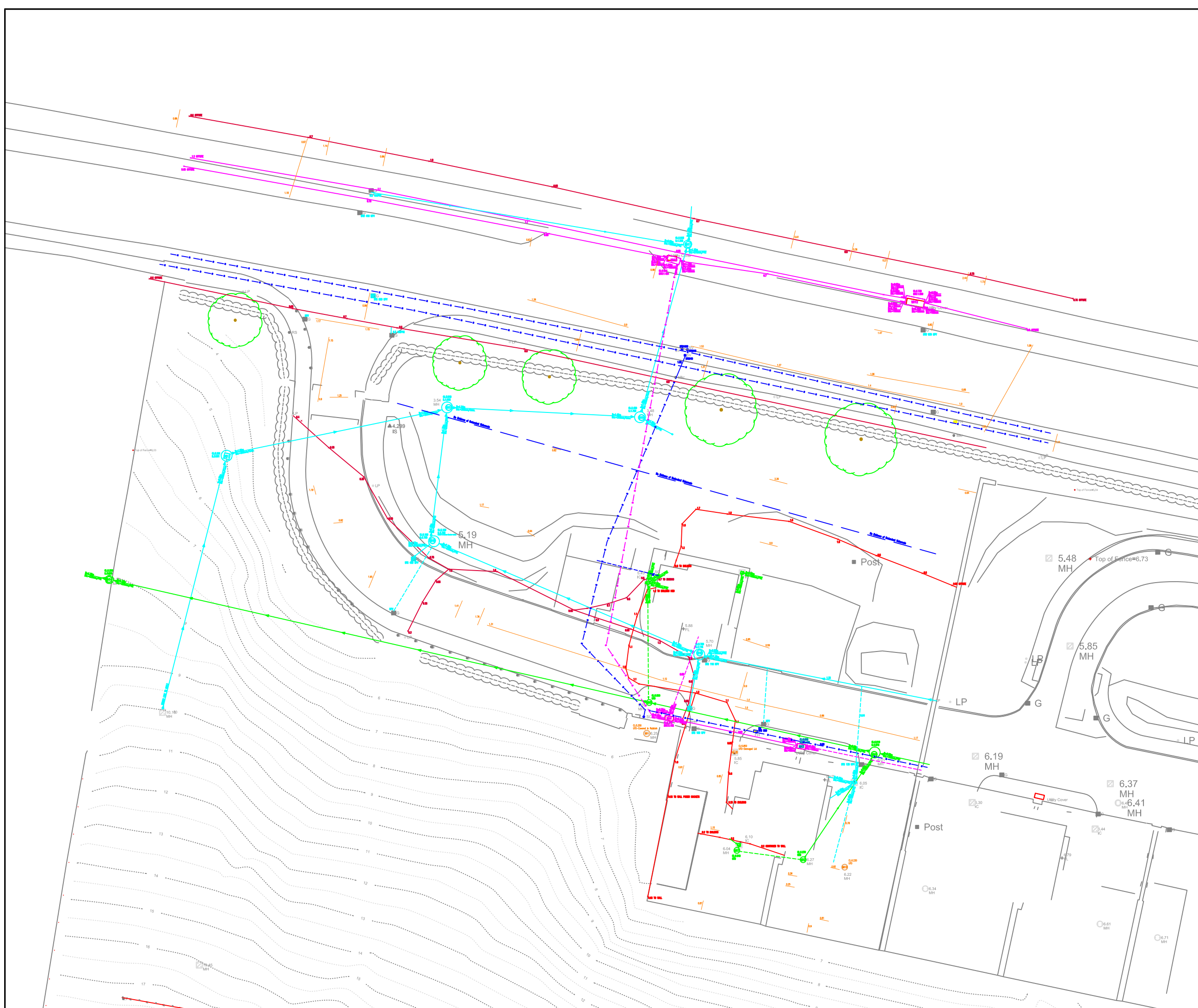

KEY PLAN
(NOT TO SCALE)



Unit 1
Enterprise, Technology &
Innovation Centre,
Clonmore Business Park,
Mullingar, Co Westmeath.

T: 01 2542680
E: info@scantech.ie
www.scantech.ie

Client: Causeway Geotech Ltd

Project Title: GPR Survey at Glenview, Sligo.

Drawing Title: Underground Services Layout

Date: 21st February 2023
Scale: 1/200 on A1
Drawing No: SGL-23031-01_01

Drawn By: R.G
Checked: D.T
Revision:

APPENDIX II
CONSTRUCTION METHODOLOGY
AND EMP

GLENVIEW HOUSING PHASE 2

PROJECT NO. S603

31st August 2023

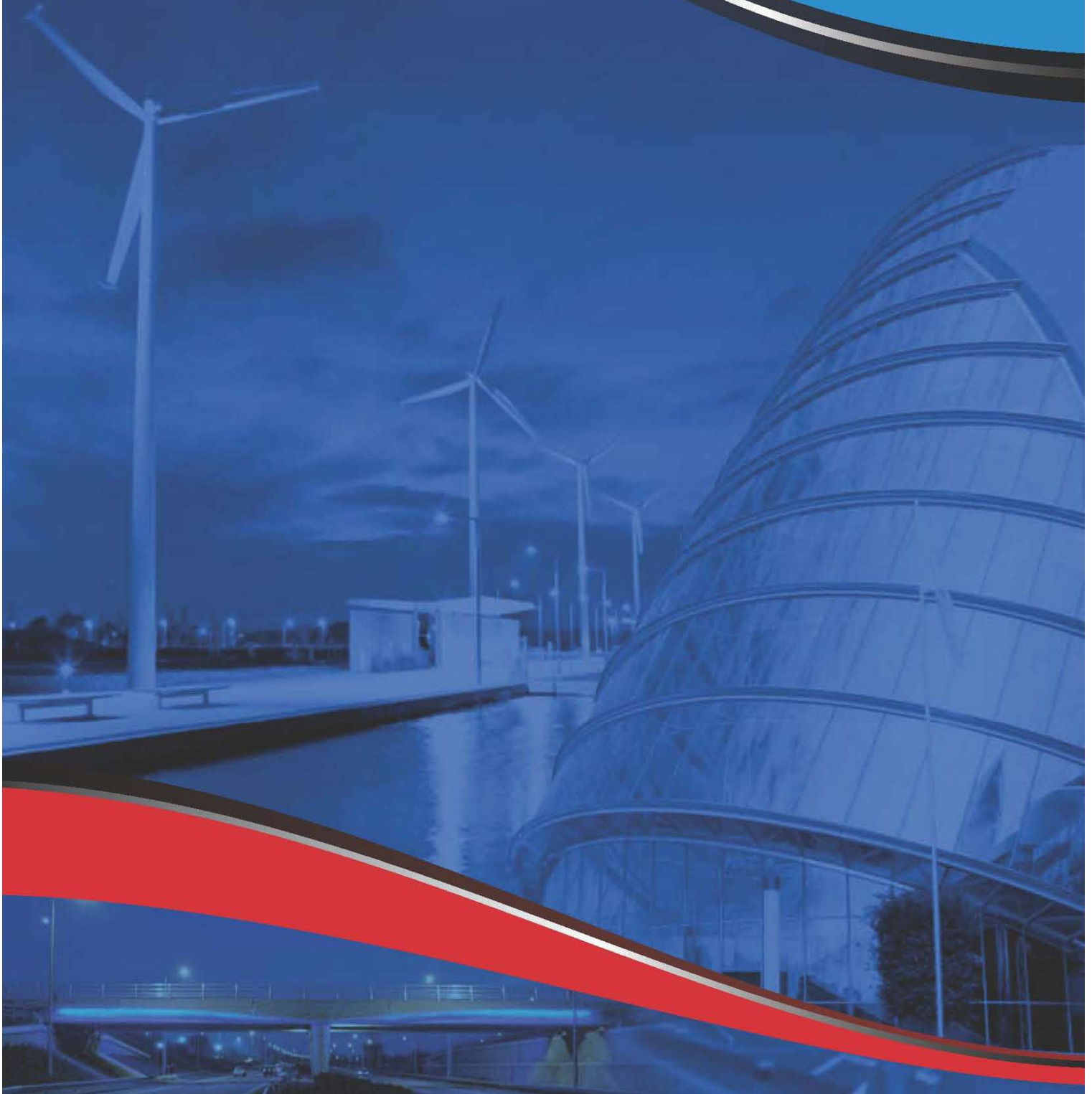

CONSTRUCTION METHODOLOGY AND EMP

GLENVIEW HOUSING PHASE 2
For Sligo County Council

PROJECT NO. S603
31st August 2023

CONSTRUCTION METHODOLOGY AND EMP

for

**Proposed Development at
Glenview Park Ash Lane Sligo**



OCSC

O'CONNOR | SUTTON | CRONIN

Multidisciplinary
Consulting Engineers

NOTICE

This document has been produced by O'Connor Sutton Cronin & Associates for its client, *Sligo County Council*. It may not be used for any purpose other than that specified by any other person without the written permission of the authors.



DOCUMENT CONTROL & HISTORY

| | | | | | | | | | |
|---------------------------------------|-------------------------|-------------------|------------------------|-------------------|-------------------|------------------|---------------|--|-----------------|
| OCSC Job No.: S603 | Project Code | Originator | Zone Volume | Level | File Type | Role Type | Number | Status / Suitability Code | Revision |
| | S603 | OCSC | XX | XX | RP | S | 0600 | S4 | P03 |
| Rev. | Status | Authors | Checked | Authorised | Issue Date | | | | |
| | | | | | | | | | |
| | | | | | | | | | |
| | | | | | | | | | |
| | | | | | | | | | |
| | | | | | | | | | |
| P03 | S4 | TD | TK | AMcD | 31.08.2023 | | | | |
| P02 | S2 | TD | TK | AMcD | 22.08.2023 | | | | |
| P01 | S2 | TD | TOD | AMcD | 07.06.2023 | | | | |

CONSTRUCTION METHODOLOGY AND EMP

TABLE OF CONTENTS

PAGE

| | |
|--|----|
| 1 INTRODUCTION..... | 1 |
| 1.1 Appointment..... | 1 |
| 1.2 Administrative Jurisdiction | 1 |
| 1.3 Existing Site Overview | 1 |
| 1.4 Proposed Development Context | 2 |
| 2 SCOPE OF CONSTRUCTION AND ENVIRONMENTAL MANAGEMENT PLAN..... | 3 |
| 3 CONSTRUCTION MANAGEMENT | 5 |
| 3.1 Overview | 5 |
| 3.2 Project Delivery..... | 6 |
| 3.3 Site Management..... | 6 |
| 3.3.1 Health & Safety..... | 6 |
| 3.3.2 Hoarding & Site Security..... | 6 |
| 3.3.3 Site Compound | 8 |
| 3.3.4 Site Access & Egress | 9 |
| 3.3.5 Deliveries to Site..... | 9 |
| 3.3.6 Storage of Materials on Site | 10 |
| 3.3.7 Removal of Materials from Site..... | 10 |
| 3.3.8 Craneage..... | 11 |
| 3.3.9 Water Supply | 11 |
| 3.3.10 Groundwater & Surface Water Control..... | 12 |
| 3.3.11 Hours of Work | 15 |
| 3.3.12 Public Awareness of Ongoing Works..... | 15 |
| 3.3.13 Environmental Management..... | 15 |
| 3.3.14 Dust | 15 |
| 3.3.15 Dirt..... | 16 |
| 3.3.16 Noise..... | 17 |
| 3.3.17 Condition Surveys..... | 18 |

| | | |
|------------|---|-----------|
| 3.3.18 | Vibrations | 18 |
| 3.3.19 | Harmful Materials..... | 19 |
| 3.3.20 | Invasive Species Prevention Measures..... | 20 |
| 3.3.21 | Site Drainage | 21 |
| 3.4 | Waste Management | 22 |
| 3.4.1 | Introduction..... | 22 |
| 3.4.2 | Waste Management in Ireland..... | 22 |
| 3.4.3 | Waste Categorisation | 26 |
| 3.4.4 | Waste Arisings..... | 28 |
| 3.4.5 | Record Keeping, Auditing & Consultation | 29 |
| 3.5 | Construction Traffic..... | 31 |
| 3.5.1 | Traffic Generation | 31 |
| 3.5.2 | Contents of Traffic Management Plan | 32 |
| 4 | PRE-CONSTRUCTION ACTIVITIES | 34 |
| 4.1 | Prior to Commencement of Development..... | 34 |
| 4.2 | Site Set Up, Security and Hoarding Lines | 34 |
| | 5 Demolition | |
| 6 | FOUNDATION & SUB-STRUCTURE WORKS | 35 |
| 6.3 | Overview | 35 |
| 6.4 | Foundations | 37 |
| 6.5 | Concrete Foundations (Strip Footings) | 38 |
| 6.6 | Piled Foundation | 40 |
| 6.7 | Storm Water Attenuation Tank..... | 41 |
| | 7 SITEWORKS | |
| 7.1 | Overview | 44 |
| 7.2 | Site Services..... | 44 |
| 7.3 | Hard & Soft Landscaping..... | 44 |
| 8 | OUTLINE CONSTRUCTION PROGRAMME..... | 46 |
| 8.1 | Overview | 46 |

1 INTRODUCTION

1.1 Appointment

O'Connor Sutton Cronin & Associates (OCSC) have been appointed by *Sligo County Council (SCC)* as part of an integrated Design Team led by SCC Housing Capital Department to undertake the Civil & Structural design for the proposed Glenview Park Group Housing development at Ash Lane Sligo. This preliminary Construction Methodology and Environmental Management Plan statement has been prepared in support of the proposed works.

1.2 Administrative Jurisdiction

The proposed development is in the jurisdiction of Sligo Co Council.

1.3 Existing Site Overview

The site for the phase 2 development is located south of Ash lane in an existing halting site outlined in Red in Figure 1 below:



Figure 1 - Site Location ([Google Maps](#))

The existing halting bay site includes 2 No halting bays and 1 No Caretakers unit with associated services with an existing entrance from the N16 Ash Lane Road. Refer to Figure 2 below.



Figure 2 – Topographical Site Survey

1.4 Proposed Development Context

The proposed works involve the demolition of the existing halting bay service units and the construction of 3 No residential housing units (1No detached and 2 No, semi-detached). It is also proposed to construct new boundary walls

within the site to facilitate subdivision of the housing units. The proposed works also include upgrade works to an existing vehicular entrance and access road to the development site at the northwest of the site, off the N16, Ash Lane Road and upgrade works to the existing access road into the development and all associated site development and drainage works. The development will involve connection to the existing Irish Water Foul Sewer network with Storm water discharged, via a petrol interceptor, Attenuation Tank, and flow control hydro brake, to an existing Local Authority Storm Water pipe network. Existing boundary block walls are to be retained within the proposed development. The redline boundary given on the drawings indicate the extents of site works for the proposed development. Figure 3 below indicates the extent of work involved.

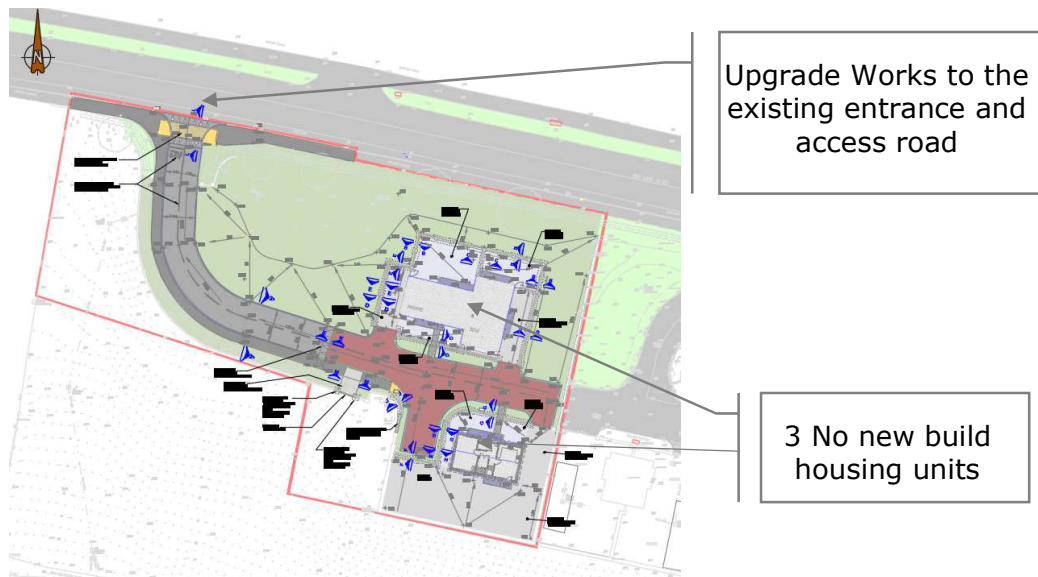

Figure 3 – Extent of Works Proposed

2 SCOPE OF CONSTRUCTION AND ENVIRONMENTAL MANAGEMENT PLAN

This report has been prepared as an outline construction strategy, setting out construction method and activities required for the demolition of the existing halting site units and construction of 3 no new residential units This outline plan

seeks to demonstrate how works can be achieved in a logical, sensible, and safe sequence with the incorporation of specific standard procedure measures to the potential impact on people and the environment. This methodology will be required to be interrogated and developed by the Main Contractor prior to commencing works on site. It is noted that this document should be viewed as an outline plan with the fully detailed Construction and Environmental Management Plan to be developed by the appointed main Contractor in consultation with Sligo Co Council Planning Authority prior to works commencing on site. The plan also demonstrates proposed construction traffic routes and areas for construction traffic set down and contractors compound areas.

Discussed in the following sections are:

- Construction Management issues
- Pre-Construction Activities
- Foundations & Substructure
- Services
- Superstructure
- Construction access routes
- Construction compounds

3 CONSTRUCTION MANAGEMENT

3.1 Overview

The works outlined in this methodology narrative outline the potential methods of construction available to the Main Contractor. The narrative indicates the prospective progress and explains the associated activities and their interdependencies and how the project will be delivered. There are a number of constraints and requirements which have been clearly considered by the Project Team throughout the design process-these will need to be further developed upon by the appointed Main Contractor prior to works commencing on site.

In broad terms, the project will be sequenced as follows:

- Pre-construction activities; access/ site set up/ hoarding;
- Site Clearance and demolition works;
- Concrete Strip Foundations;
- Piled Foundations
- Site services;
- Construction of Superstructure;
- Construction of Retaining walls;
- Mechanical & electrical works;
- Hard and soft landscaping;
- Completion;

3.2 Project Delivery

The project is proposed to be constructed in a single phase incorporating all new build units, new retaining walls, upgrade works to existing road junction / access road and storm water network including attenuation tank. The works will also involve diversion of the existing Irish Water, watermain. It is proposed to commence in late 2023 and take approximately 12 months to complete.

3.3 Site Management

The Main Contractor will be responsible for overall site management for the duration of the proposed works. Discussed below are a number of areas which the Main Contractor will be required to address within their Construction Environmental Management Plan and during the works.

3.3.1 Health & Safety

The Main Contractor will act as PSCS, must progress their works with reasonable skill, care, diligence and to, at all times, proactively manage the works in a manner most likely to ensure the safety and welfare of those carrying out construction works, interacting stakeholders, adjoining residents, and the public. Contractors are further required to ensure that, as a minimum, all aspects of their works and project facilities comply with good industry practice, statutory instruments, and all necessary consents. These will be further expanded and developed within the Main Contractor's Construction Management Plan in relation to Health & Safety requirements.

3.3.2 Hoarding & Site Security

The construction site will require a site compound located within the redline boundary and perimeter hoarding by the Main Contractor following possession of site to enclose the proposed works. The overarching consideration in all elements of the site set-up will be to ensure the works can be undertaken in a safe manner for members of the public, the Main Contractor and their staff as well as protecting the surrounding environment.

The Main Contractor will commence by erecting suitably robust hoarding around the site perimeter. The hoarding must ensure segregation of the general public from the proposed works areas. This will typically take the form of a standard Harris fence type hoarding. Appropriate access points will be provided to the site through the hoarding.

The proposed hoarding alignment for the main construction phase of the works is indicatively shown in dashed purple line in Figure 4 below. It is noted that this plan layout may be altered locally during the works to facilitate different works such as foundations, works to existing road junction, craneage operations, drainage and the like.

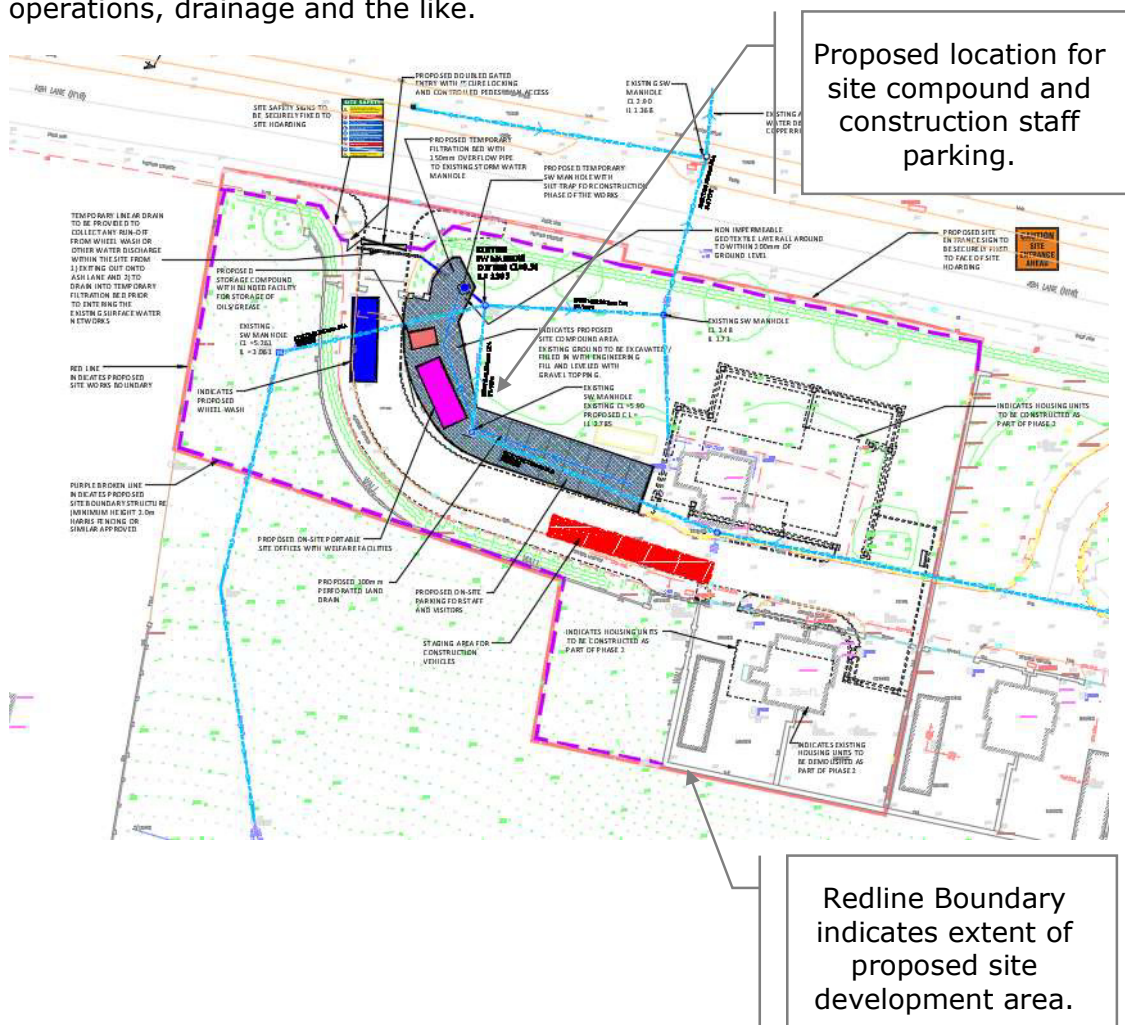

Figure 4 – Proposed Site Hoarding adjacent to the proposed works – Broken Purple Line.

The Main Contractor will be responsible for the security of the site for the duration of the works. The Main Contractor will be required to:

- Install and maintain adequate site hoarding to the site boundary with adequate controlled access and egress points;
- Maintain site security staff at all times;
- Install secure access in the form of turn-styles and gates for staff;
- Ensure restricted access control is maintained to the works;
- Operate a site induction process for all site staff and visitors;
- Ensure all staff have current 'Safe Pass' and Construction Skills Cards;
- Monitor and record all deliveries to site and all material/waste taken off site for disposal to appropriate licences facility.

All staff and operatives will be fully inducted into the security, health and safety and logistic requirements on site.

3.3.3 Site Compound

The extent of compound and facilities required by the Main Contractor will vary throughout the duration of the works. The initial phase of works involving site set-up, condition surveys, diversions of services (where and if required) and commencement of siteworks are likely to have limited requirements for Contractor's facilities. As the works advance, the Main Contractor's compound and facilities will be required to be enhanced. It is envisaged that such facilities will be provided within the hard and soft landscaped portions of the development, with locations to be selected by the Main Contractor to best suit their works methodologies and sequencing in agreement with Sligo County Council. As the works near completion, the requirements for facilities will be reduced and thus will allow the Main Contractor to remove sections of the compound to be able to complete the hard and soft landscaping works. Possible locations for the Contractors compounds are to be agreed.

3.3.4 Site Access & Egress

The key driver in the provision of site access and egress is to ensure that safety of the public and the Contractor's staff is maintained at all times. It is envisaged that access will be via the existing site entrance located at the northwest of the site off the N16 Ash Lane Road, shown as follows in Figure 5:



Figure 5 – Vehicular and Pedestrian Construction Routes

3.3.5 Deliveries to Site

Construction deliveries to site will make use of the access and egress point indicated in Figure 5 above. A "just in time" approach will generally be required for delivery of particular materials such as concrete and prefabricated structural elements. That is to say that deliveries of materials will be planned, sequenced, and programmed to ensure that materials as they are required on site. Works requiring multiple vehicle deliveries to site, such as concrete pours, should be planned well in advance. The Main Contractor will be responsible for ensuring that this will not impact upon the movement of the public, pedestrians or vehicles

using the existing N16 Ash Lane traffic route. The Main Contractor will be required to provide a flagman to direct construction vehicles entering/exiting the site and manage the interaction between public and construction vehicle movements in a safe manner as required.

3.3.6 Storage of Materials on Site

There is scope for some storage of materials around the site. Any materials stored on site will be done so in a safe manner. Any fuels or chemicals on site will be stored within double sealed tanks within bunds using standard practice procedures. A dedicated plant refuelling point will be set up on site. All fuels and chemicals required to be stored on site will be clearly marked.

3.3.7 Removal of Materials from Site

The removal of materials from site will primarily be undertaken during the initial stages of the works. This will involve the removal of excavated material to facilitate the construction of the foundations and attenuation tank envisaged to be required. This phase of works will need to be managed effectively to ensure that no queuing of trucks occurs on public access routes. All trucks will have a built-on tarpaulin that will cover excavated material as it is being hauled off site and wheel wash facilities will be provided at the site egress location. All vehicles will make use of the access and egress points noted in Section 3.3.4 above. The Main Contractor will be required to provide a flagman to direct construction vehicles entering/exiting the site and manage the interaction between public and construction vehicle movements in a safe manner around the proposed construction vehicular and staff routes.

Earthworks will take place during periods of low rainfall to reduce run-off and potential suspended solids generation.

Wheel washers and dust suppression are to be employed on site with regular plant maintenance to ensure minimal sediment build of sediment on roads to minimise risk to surface water drainage.

3.3.8 Craneage

The works may require the use of cranes on site. The final chosen structural form of the proposed building works will determine the likely type of cranes, the type and size of crane, mobile cranes or otherwise would be used for the installation of the superstructures and concrete pours. Crane bases may be required and size and location to be advised.

Crane booms vary in length from about 10m to 60m and the payload versus outreach depends on the crane deployed for the task.

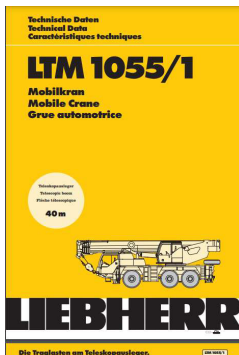

5Tonnes @ 20m Outreach

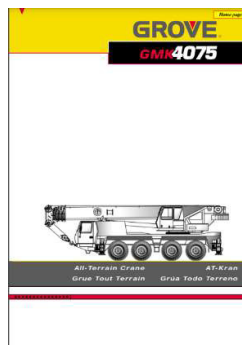

7 Tonnes @20m; 5 Tonnes @24m.

3.3.9 Water Supply

The Contractor will require a water source for the duration of the works. Water will be required for:

- Contractor's welfare facilities;
- Vehicle washdown (use recycled water where feasible);
- Dust suppression (as applicable);

It is proposed that the Main Contractor will make use of existing water connections on the site for the purpose of water supply during the works.

3.3.10 Groundwater & Surface Water Control

The Contractor will be required to prepare and implement a site wide Surface Water collection and disposal plan that fully details all measures for groundwater and surface water control for agreement with the local authority prior to discharge of same from site. The extent of surface water will be minimal given the extent of the works. Details of the proposed collection, treatment, and discharge of surface water during the construction phase is given on drawing No S603-OCSC-XX-XX-DR-C-0606-S2-P01 – refer to Appendix A. The following Figure 6 is an extract from this drawing.

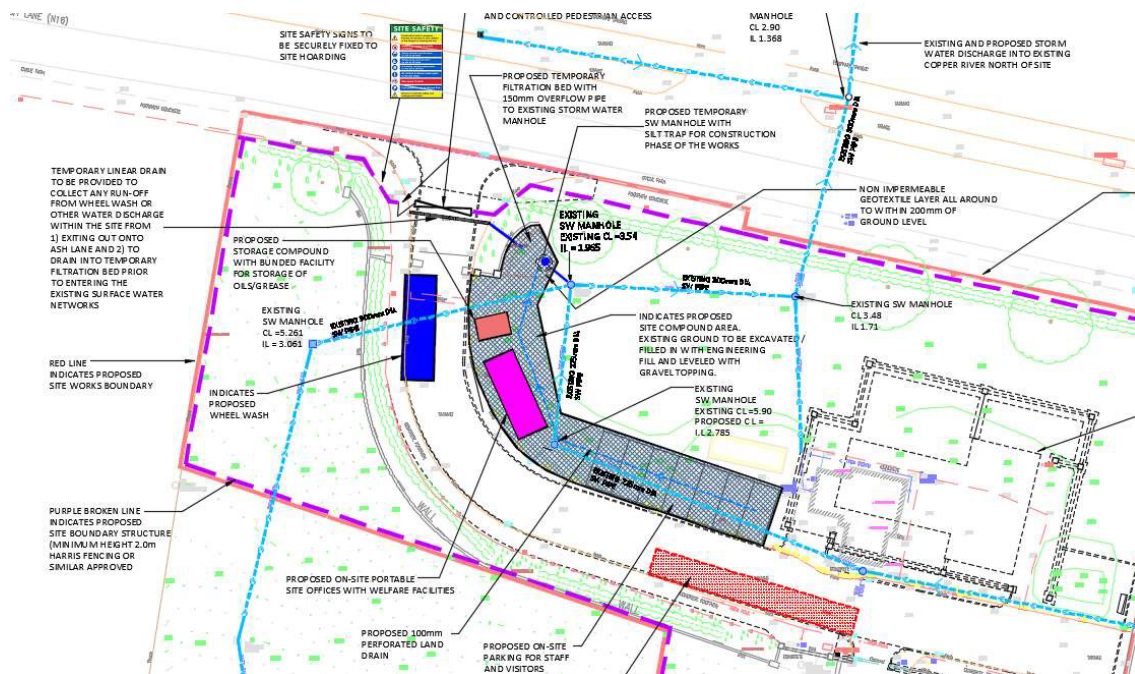

Figure 6 – Surface Water Disposal during Construction

Surface Water will be collected via a perforated drain constructed within the engineering fill (location of the site offices, oil compound and staff parking) and a temporary linear drain at the exit to the existing site which will flow by gravity into a filtration bed. Water is to discharge from the Filtration bed via a temporary

Silt Trap Manhole into an existing local authority storm water pipe network. Refer to Figure 7:

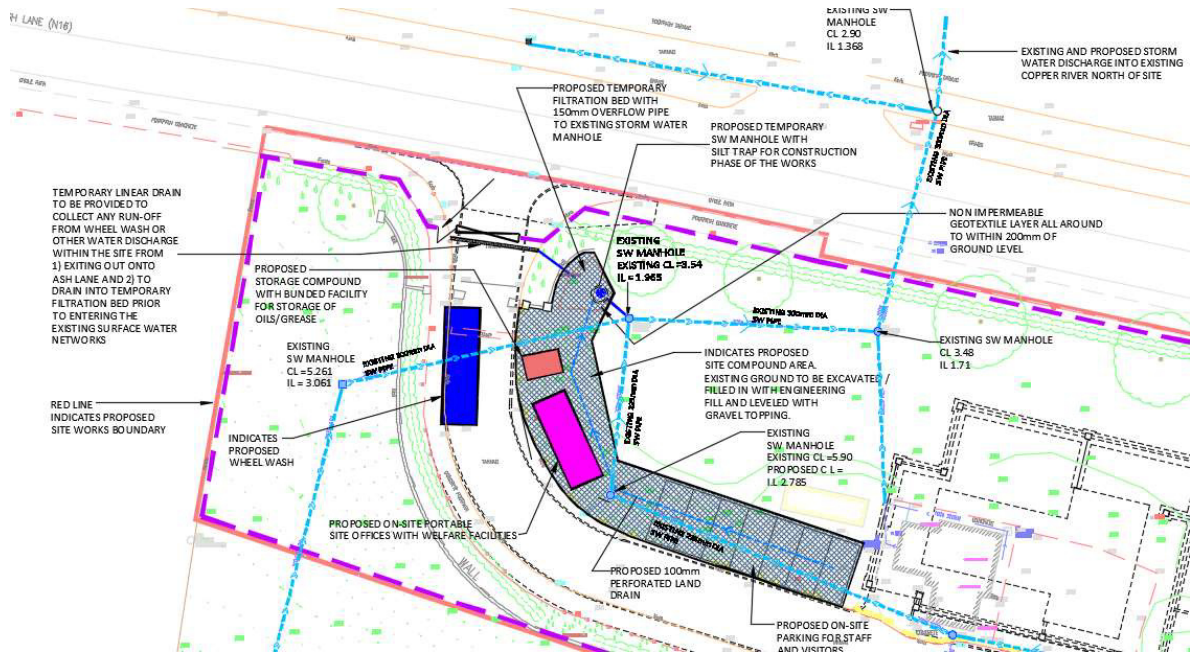

Figure 7 – Surface Water sedimentation and pollutant removal process.

The existing storm water pipe network discharges into the Copper River to the North of the site. The stone engineering fill, linear drain, lined stone filtration bed and silt trap manhole will provide the collection, reduction in flow velocities and filter out sedimentation / pollutant's removal during the construction phase of the works preventing any unclean water discharging into the Cooper River north of the site. Refer to drawing No S603-OCSC-XX-XX-DR-C-0606-S2-P01 which details the surface water collection, treatment, and discharge from site – refer to Appendix A.

If ground water is encountered during excavations, the water will be pumped from the excavation and discharged through a pumped main into the filtration bed.

The ground investigation carried out by Causeway Geotech indicates that groundwater strikes vary throughout the site. Refer to Figure 8 & Table 1 below:

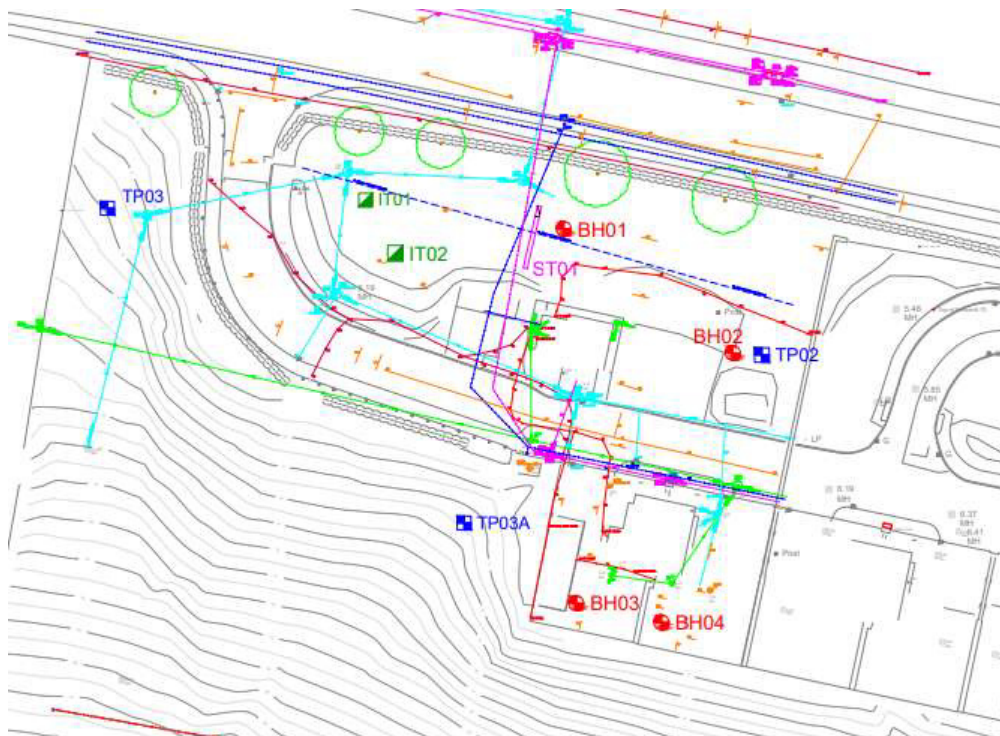

Figure 8 – Ground Investigation Layout

Details of the individual groundwater strikes, along with any relative changes in levels as works proceeded, are presented on the exploratory hole logs for each location.

Groundwater was encountered during the ground investigation as water strikes shown in Table 1.

Table 1. Groundwater strikes encountered during the ground investigation.

| Location | Depth (mbgl) | Comments |
|----------|--------------|--|
| BH01 | 3.00 | Water rose from 3.00m to 2.85m over 20 minutes |
| IT02 | 0.65 | Fast seepage |

Groundwater was not noted during drilling of BH02. However, it should be noted that the casing used in supporting the borehole walls during drilling may have sealed out additional groundwater strikes and the possibility of encountering groundwater during excavation works should not be ruled out.

Groundwater was not noted during excavation of any of the other pits or trenches.

3.3.11 Hours of Work

It is envisaged that the hours of work for the project will be as follows, unless conditioned otherwise:

- Monday to Friday 7.00am to 7.00pm
- Saturday 8.00am to 2.00pm
- Sundays and Bank Holidays No activity on site

We note that certain activities may be required, subject to prior agreement with Sligo Co Council to be undertaken outside of these working hours.

3.3.12 Public Awareness of Ongoing Works

The site is located adjacent to the existing N16 road, west of Sligo Hospital & ATU Sligo. The Main Contractor will be required to ensure that all agents, sub-contractors, and suppliers act in a manner to minimise disruption to existing vehicular and pedestrian traffic. Construction staff will be encouraged to remove all Personal Protective Equipment (PPE) and use wash down facilities before leaving the site.

The contractor will be responsible for keeping people informed of site operations, through site signage.

3.3.13 Environmental Management

The appointed Contractor will be required to be accredited with ISO 14001 Environmental Management Systems.

3.3.14 Dust

A Dust Minimisation Plan will be formulated for the construction phase of the project. Dust prevention measures shall be included for control of any site airborne particulate pollution. The Contractor shall put in place a regime for

monitoring dust levels in the vicinity of the site during the works using the Bergerhoff Method. The minimum criteria to be maintained shall be the limit specified by the environmental Protection Agency (EPA) for licensed facilities in Ireland which is 350mg/m²/day as a 30-day average. The Contractor shall continuously monitor dust over the variation of weather and material disposal to ensure the limits are not breached throughout the project.

The level of monitoring and adoption of mitigation measures will vary throughout the construction works depending on the type of activities being undertaken and the prevailing weather conditions at the time. Additional monitoring and mitigation such as damping down of earth mounds on site would be undertaken if the prevailing weather conditions are dry and windy. It is noted that the stockpiling of excavated material on site is to be minimised with an immediate removal of excavated materials.

Where soil is to be stockpiled it is to be done within the site boundary confines.

3.3.15 Dirt

There will be small volumes of traffic generated by aspects of the construction works, particularly during the excavations and groundworks phase, it shall be a requirement that the Contractor shall ensure, where appropriate:

- A wheel wash facility shall be provided at each egress point from the site.
- All vehicles shall be required to pass through the wheel wash facility before exiting the site to the public & private road networks. The wheel wash must be kept in place and used throughout the critical dirt generating activities of the construction works.
- A temporary linear drain will be located downstream of the wheel wash facility to ensure no water use in the cleaning process exist the site and is instead diverted into the proposed filtration bed given on

drawing No S603-OCSC-XX-XX-DR-C-0606-S2-P01 – Refer to Appendix A.

- Road sweepers shall be retained for the duration of the construction works with an increase in cleaning during the critical dirt/dust generating works. Regular road drain clearing will be implemented.
- Water supplies shall be recycled for use in the wheel wash. All surface waters shall be drained through appropriate pipe networks and filter material prior to discharge from the site. Refer to drawing No S603-OCSC-XX-XX-DR-C-0606

3.3.16 Noise

We do not envisage any site operations that will cause excessive noise over and above normal construction activities. The Contractor shall be required to monitor baseline noise levels at the site prior to commencement of the project, with a noise monitoring regime being developed for the duration of the construction works on site. Variation of noise levels from those experienced as part of everyday life in the area can result in disruption. The Contractor shall implement measures to minimise and mitigate noise levels during construction. Specifically, noise levels shall be kept below levels identified in Table 2 over or if further limits as imposed by the Local Authority. Peak noise levels outside of the one-hour dBA measurement shall be in line with HAS guidelines.

| Period over which criterion applies | | Noise Impact Criterion ($L_{Aeq, 1hr}$) |
|---|-------------------------|--|
| Monday to Friday | Day 07:00 to 19:00 | 75dBA |
| | Evening: 19:00 to 22:00 | 60dBA* |
| | Night 22:00 to 07:00 | The higher of 45dBA of the ambient level* |
| Saturday: Day 08:00 to 14:00 (work outside these hours no higher than 45dB of ambient noise level) | | 70dBA |
| Sundays and Bank Holidays | Day 08:00 to 14:00 | 60dBA* |

Note-*Construction activity at these times, other than that required for emergency works, will require the explicit permission of the relevant local authority.

Table 2 – Noise Limit Criteria

Plant machinery will be chosen to avoid significant low-frequency noise emissions which increases nuisance potential to Bats in surrounding areas. Noisier plants will be positioned to optimise screening by other plant machinery. Plant machinery will be turned off when not in use.

3.3.17 Condition Surveys

Condition surveys of the existing halting site units and areas adjoining the works shall be undertaken by a specialist survey company engaged by the Main Contractor prior to any works commencing on site. The survey company will record, within a Condition Report using photographs and sketches, the current structural condition of the halting site units.

3.3.18 Vibrations

Vibration monitoring (as a minimum) of the following areas shall be carried out for the duration of the works:

Vibration monitoring stations should continually log vibration levels (including associated frequency) using the Peak Particle Velocity parameter (PPV, mm/s) in the X, Y and Z directions, in accordance with BS ISO 4866: 2010: Mechanical vibration and shock – Vibration of fixed structures – Guidelines for the measurement of vibrations and evaluation of their effects on structures. Vibration monitors, of both aural and visual type, with real time outputs to be located at agreed points.

The mounting of the recording equipment to the vibrating structure (or surface supporting sensitive equipment) shall comply with BS ISO 5348: 1998: Mechanical vibration and shock – Mechanical mounting of accelerometers. In summary, the following ideal mounting conditions apply:

- The recording equipment and its mountings should be as rigid as possible;
- The mounting surfaces should be as clean and flat as possible;
- Simple symmetric mountings are best, and;

- The mass of the mounting should be small in comparison to that of the structure under test.

The vibration limits for the duration of the construction works shall be set in line with the vibration criteria to be adopted at nearby sensitive on-site historical properties to avoid cosmetic damage, as taken from the German Standard DIN 4150-3 (1999-02) *Structural Vibration – Effects of vibration on structure*.

Traffic light system to be in place consisting of:

- **Green**-vibrations below all threshold limits-OK to proceed;
- **Amber**-vibrations exceed first threshold limit (2/3rds of limit)-Stop and check;
- **Red**-vibrations exceed second threshold-Stop and action.

3.3.19 Harmful Materials

Harmful materials will be stored remote from the site works for use in connection with the construction works only. The following on site measures will be included for the works to prevent any spillages of fuels.

- Designation of bunded refuelling areas on site;
- Provision of spill kit facilities across the site and personnel trained in its use;
- Where mobile fuel bowsers are used, the following measures will be taken:
 - Any flexible pipe, tap or valve will be fitted with a lock and will be secured when not in use;
 - The pump or valve will be fitted with a lock and secured when not in use;
 - All bowsers to carry a spill kit and operatives must have spill response training;

- Portable generators or similar fuel containing equipment will be placed on drip trays.

In the case of drummed fuel or other potentially polluting substances which may be used during construction, the following measures will be adopted:

- Secure storage of all containers that contain potential polluting substances in a dedicated internally bunded chemical storage cabinet unit or inside a concrete bunded area;
- Clear labelling of containers so that appropriate remedial measures can be taken in the event of a spillage;
- All drums to be quality approved and manufactured to a recognised standard;
- If drums are to be moved around site, they should be done so secured and on spill pallets;
- Drums to be loaded and unloaded by competent and trained personnel using appropriate equipment.

3.3.20 Invasive Species Prevention Measures

Good construction site hygiene will be employed to prevent the introduction and spread of problematic invasive alien plant species (e.g., Rhododendron, Japanese Knotweed, Giant Rhubarb etc.) by thoroughly washing vehicles prior to entering the site. Refer to Figure 9 below for location:

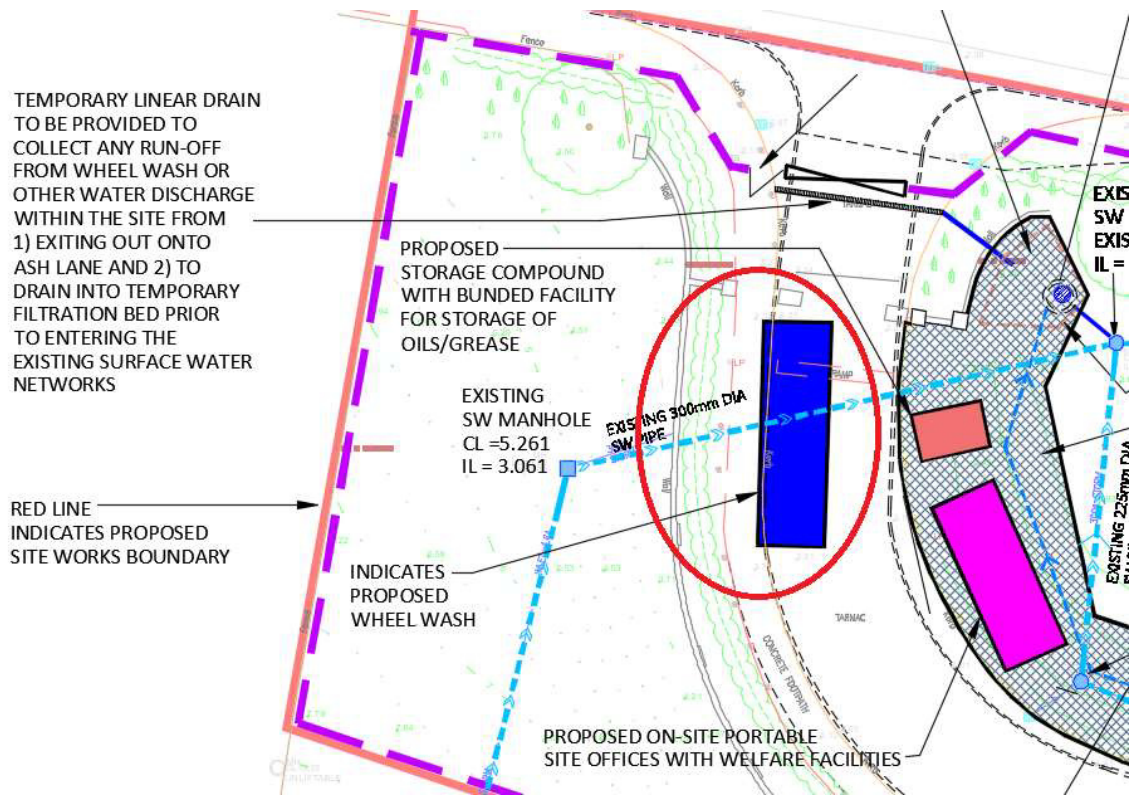

Figure 9 – Wheel wash Location

Materials used on site will be confirmed to be from a clean source that is free of invasive species.

3.3.21 Site Drainage

As construction advances there may be a small requirement to collect and treat surface water within the site. This will be completed using perimeter swales at low points around the construction areas, and if required water will be pumped from the swales into sediment bags prior to overland discharge allowing water to percolate naturally to ground. Daily monitoring and inspections of site drainage during construction will be carried out. A log will be maintained of daily inspections and status of drainage features. The log will be available on site for inspection.

3.4 Waste Management

3.4.1 Introduction

The appointed contractor will be responsible for the preparation of a detailed site-specific resource and waste management plan (RWMP) to be submitted to Sligo Co Council prior to commencement of works. Discussed below are key areas that will be developed upon by the Main Contractor in their detailed plan.

3.4.2 Waste Management in Ireland

Overarching Legislation

The overarching legislative instruments governing waste management in Ireland are as follows:

- Waste Management Act 1996 (S.I. No. 10 of 1996) as amended 2001 (No. 36 of 2001), 2003 (No. 27 of 2003) and 2011 (No. 20 of 2011)
- Sub-ordinate legislation includes:
 - European Communities (Waste Directive) Regulations 2011 (S.I. 126 of 2011) as amended 2011 (S.I. No. 323 of 2011) and 2016 (S.I. 315 of 2016);
 - Waste Management (Collection Permit) Regulations 2007 (S.I. No. 820 of 2007) as amended 2008 (S.I. No. 87 of 2008), 2015 (S.I. No. 197 of 2015) and 2016 (S.I. No. 24 and 346 of 2016);
 - Waste Management (Facility Permit and Registration) Regulations 2007 (S.I. No. 821 of 2007) as amended 2008 (S.I. No. 86 of 2008), 2014 (S.I. No, 320 and No. 546 of 2014) and 2015 (S.I. No. 198 of 2015);
 - Waste Management (Licensing) Regulations 2000 (S.I. No. 185 of 2000) as amended 2004 (S.I. No. 395 of 2004), 2010 and (S.I. No. 350 of 2010);
 - Waste Management (Packaging) Regulations 2014 (S.I. 282 of 2014) as amended 2003 (S.I. No. 61 of 2003) as amended

- 2004 (S.I. No. 871 of 2004), 2006 (S.I. No. 308 of 2006) and 2007 (S.I. No. 798 of 2007);
- Waste Management (Planning) Regulations 1997 (S.I. No. 137 of 1997);
- Waste Management (Landfill Levy) Regulations 2015 (S.I. No. 189 of 2015) as amended 2011 (S.I. No. 434 of 2011) as amended 2012 (S.I. No. 221 of 2012);
- European Union (Waste Electrical and Electronic Equipment) Regulations 2014 (S.I. No. 149 of 2014);
- European Union (Batteries and Accumulators) Regulations 2014 (S.I. No. 283 of 2014) as amended 2014 (S.I. No. 349 of 2014) and 2015 (S.I. No. 347 of 2015);
- Waste Management (Food Waste) Regulations 2009 (S.I. 508 of 2009);
- European Union (Household Food Waste and Bio-waste) Regulation 2015 (S.I. No. 191 of 2015);
- Waste Management (Hazardous Waste) Regulations 1998 (S.I. No. 163 of 1998) as amended 2000 (S.I. No. 73 of 2000);
- Waste Management (Shipments of Waste) Regulations 2007 (S.I. No. 419 of 2007) as amended;
- Waste Management (Movement of Hazardous Waste) Regulations 1998 (S.I. No. 147 of 1998);
- European Communities (Transfrontier Shipment of Waste) Regulations 1998 (S.I. No. 147 of 1998) as amended 1994 (SI 121 of 1994);
- European Union (Properties of Waste which Render it Hazardous) Regulations 2015 (S.I. No. 233 of 2015).
- Litter Pollution Act 1997 (S.I. No. 12 of 1997) as amended by Protection of the Environment (amendment) Act 2003 as amended;
- Planning and Development Act 2000 as amended (S.I. No. 30 of 2010) and 2015 (S.I. No. 310 of 2015);

- Protection of the Environment Act 1992 as amended 2003 (S.I. No. 413 of 2003) and by Planning and Development Act 2000 as amended (S.I. No. 30 of 2010).

The above Acts and Regulations transpose European Union policy and Directives into Irish law. The over-riding 'Duty of Care' principle implies that the producer is responsible for waste from the time it is generated through until its legal disposal (including its method of disposal.). As it is not practical in most cases for the waste producer to physically transfer all waste from where it is produced to the final disposal area, waste contractors will be employed to transport waste to the final waste disposal site.

A waste collection permit, issued by the National Waste Collection Permit Office (NWCPO), must be held by every waste contractor engaged on the project. Waste receiving facilities must also be appropriately permitted or licensed to accept waste. Operators of such facilities cannot receive any waste, unless in possession of a waste permit granted by the relevant Local Authority under the Waste Management (Facility Permit & Registration) Regulations 2007 and Amendments or a waste licence granted by the Environmental Protection Agency (EPA). The permit/licence held will specify the type and quantity of waste able to be received, stored, sorted, recycled and/or disposed of at the specified site.

National Waste Management Policy

The 1998 '*Changing Our Ways*' policy document by the Irish Government identified objectives for the prevention, minimisation, reuse, recycling, recovery, and disposal of waste in Ireland. The target for C&D waste in this report was to recycle at least 50% of C&D waste within an initial five-year period with incremental increases to at least 85% by 2013. A waste industry task force of the *Forum for the Construction Industry* released '*Recycling of Construction and Demolition Waste*' recommending the development of a

voluntary construction industry programme to meet Government objectives for the recovery of C&D waste. 'A Resource Opportunity - Waste Management Policy in Ireland' published in 2012 stresses the environmental and economic benefits of better waste management, particularly in relation to waste prevention. In respect of C&D waste, the report commits to undertaking a review of specific producer responsibility requirements for C&D projects above a certain threshold. The National Construction and Demolition Waste Council (NCDWC) published 'Best Practice Guidelines for the Preparation of Waste Management Plans for Construction and Demolition Projects' in 2006 in conjunction with the Department of the Environment, Heritage, and Local Government (DoEHLG). The Guidelines outline the issues that need to be addressed at the pre-planning stage of a development all the way through to its completion. These Guidelines have been followed in the preparation of this document and include the following elements:

- Predicted C&D wastes and procedures to prevent, minimise, recycle, and reuse wastes;
- Waste disposal/recycling of C&D wastes at the site;
- Provision of training for waste manager and site crew;
- Details of proposed record keeping system;
- Details of waste audit procedures and plan; and
- Details of consultation with relevant bodies i.e., waste recycling companies, Sligo County Council etc.

In accordance with Section 3 of the Guidelines Construction and Demolition Waste Management plans should be submitted as part of development proposals for projects in excess of any of the following thresholds:

- New residential development of 10 units or more;
- New developments other than above, including institutional, educational, health and other public facilities, with an aggregate floor area in excess of 1,000m²;
- Demolition/renovation/refurbishment projects generating in excess of 100 cubic metres in volume of construction and demolition waste, and;

- Civil engineering projects in excess of 500 cubic metres of waste materials used for development works on the site.

3.4.3 Waste Categorisation

Typical non-hazardous and hazardous waste streams generated by construction and demolition activities at typical sites are shown in Table 3 along with their accompanying European Waste Code (EWC) Classification.

It is anticipated that the non-hazardous materials listed above will be encountered during the proposed works with the potential for some of the hazardous materials as discussed over.

| Waste Materials Categorisation | | |
|--------------------------------|--|----------|
| Category | Description | Code |
| Non-Hazardous | Metals | 17 04 |
| | Wood, glass, plastic | 17 02 |
| | Soil, stones, dredged soils | 17 05 |
| | Gypsum based materials | 17 08 |
| | Cardboard | 15 01 01 |
| | Glass | 17 02 02 |
| | Bituminous mixtures, coal tar, tar products | 17 03 |
| | Concrete, bricks, tiles, ceramics | 17 01 |
| Hazardous | Electrical and Electronic Components | 16 02 |
| | Liquid Fuels | 13 07 |
| | Wood Preservatives | 03 02 |
| | Batteries | 16 06 |
| | Soil and stones containing dangerous substances | 17 05 03 |
| | Waste construction material containing asbestos | 17 06 05 |
| | Other construction and demolition wastes containing dangerous substances | 17 09 03 |

Table 3 – Waste Material Categorisation

Non-Hazardous Materials

The classification of materials as non-hazardous and/or hazardous will be based on the www.hazwasteonline.com web based system as well as classification using Waste Acceptance Criteria in accordance with the European Communities (EC) Council Decision 2003/33/EC, which establishes criteria for the acceptance of waste at landfills.

In addition, non-hazardous waste materials are likely to be generated during all phases of the construction works from casting of concrete, through to completion of structures and mechanical and electrical services etc.

Hazardous Materials

There is the potential for hazardous materials to be uncovered, particularly during the demolitions and excavations phases of the project as discussed below:

- ***Contaminated Soil***

The building works will require excavations to facilitate foundation construction, together with installation of below ground services. Given the greenfield / brownfield nature of the site, there is little potential for the soil to have elements of contaminant contained within it. An initial assessment of the site will be undertaken by OCSC to classify the materials to be encountered on site from a waste soils perspective. The Main Contractor will be responsible for the classification of all material to be removed from site and compliant disposal in accordance with the Waste Management Act 1996 as amended and all relevant Regulations.

- ***Fuels/Oils***

There will be no site storage of fuels or oils during the demolition, excavation, or construction phases of the project. Provided that these requirements are adhered to, and site crew are trained in the

appropriate refuelling techniques, it is not expected that there will be any fuel/oil wastage at the site.

3.4.4 Waste Arisings

The Environmental Protection Agency (EPA) produce figures on the amounts of waste generated by various developments. These figures are contained in EPA databases. The split between individual C&D waste categories is shown in Table 4.

| Waste Types | % |
|--------------------------------------|------|
| Metals | 2.2 |
| Concrete, Brick, Tile, Gypsum | 7.2 |
| Bituminous mixtures | 1.3 |
| Mixed C&D waste | 4.5 |
| Soils & Stones | 84.8 |
| Total | 100 |

Table 4 – Waste Generation

Further figures are available for typical overall waste generation figures for construction sites based on the type and scale of development.

It should be noted that until final materials and methods of construction have been determined it is not possible to predict with a high level of accuracy the construction waste that will be generated. These details will be required to be included by the Main Contractor in their RWMP to be prepared and agreed with MCC in advance of works commencing on site.

Site Waste Management Operations

Waste materials generated will be segregated on site where it is practical. Where the on-site segregation of certain waste types is not practical, off-site

segregation will be carried out. There will be skips and receptacles provided to facilitate segregation at source. All waste receptacles leaving site will be covered or enclosed. The appointed waste contractor will collect and transfer the wastes as receptacles are filled.

Any soil removed off-site will be carried by contractors licensed under the Waste Management Acts 1996 - 2008, the Waste Management (Collection Permit) Regulations 2007 and Amendments and the Waste Management (Facility Permit & Registration) Regulations 2007 and Amendments. Waste arising shall be handled by an approved waste contractor holding a current waste collection permit. All waste arising requiring disposal off-site will be disposed of at a facility holding the appropriate licence or permit, as required.

Written records will be maintained by the contractor(s) detailing the waste arising throughout the construction and demolition phases, the classification of each waste type, the contact details and waste collection permit number of all waste contractors who collect waste from the site and the end destination and waste facility permit or licence number for all waste removed and disposed off-site. Dedicated bunded storage containers will be provided for hazardous wastes such as batteries, paints, oils, chemicals etc., if required.

3.4.5 Record Keeping, Auditing & Consultation

Record Keeping

Records will be kept for each waste material, which leaves the site, either for reuse on another site, recycling, or disposal. A system will be put in place to record the construction waste arisings on site.

The Waste Manager or a member of his team will record the following:

- Waste taken for Reuse off-site (i.e., for capping of landfill cells or at another site);
- Waste taken for Recycling;
- Waste taken for Disposal;
- Reclaimed waste materials brought on-site for reuse.

For each movement of waste on- or off-site, the Waste Manager will obtain a signed docket from the contractor, detailing the weight and type of the material and the source and destination of the material. This will be carried out for each material type. This system will also be linked with the delivery records. In this way, the percentage of construction waste generated for each material can be determined.

The system will allow the comparison of these figures with the targets established for the recovery, reuse, and recycling of construction waste and to highlight the successes or failures against these targets.

Outline Waste Audit Procedure

The appointed Waste Manager on site will be responsible for conducting a waste audit at the site. A review of all the records for the waste generated and transported on- or off-site will be undertaken. If waste movements are not accounted for, the reasons for this should be established in order to see if and why the record keeping system has not been maintained.

A Summary Report will be prepared and compared with the established recovery/reuse/recycling targets for the site. Each material type will be examined, in order to see where the largest percentage waste generation is occurring. The waste management methods for each material type will be reviewed in order to highlight how the targets can be achieved. Waste management costs will also be reviewed.

Consultation

Consultation with waste contractors and Sligo County Council through the construction phase will be pursued to ensure best practices for waste management are being followed on site.

3.5 Construction Traffic

The proposed development will have a certain amount of construction traffic to facilitate the works. The construction access strategy to serve the site will still need to be developed by the Main Contractor in a manner taking cognisance of the existing road junction and access road of both pedestrian and vehicular traffic on the N16 road adjacent to the site.

It is envisaged that construction will be via the existing site entrance at the northwest of the site.

3.5.1 Traffic Generation

It is envisaged that traffic will be generated for the duration of the works by the proposed development. This will be from a number of sources:

- Hauling of excavated material off site;
- Hardcore and Small Volumes of Concrete deliveries;
- Deliveries of reinforcement & formwork to site;
- Deliveries of prefabricated structural steel elements if required;
- Deliveries of Timber Products
- Deliveries of building services equipment to site;
- Construction Workers.

Designated parking for construction workers will be provided within the site adjacent to the main site compound(s).

The levels of construction traffic will vary during the weeks with peak volumes predicted to be during the following activities:

- **Foundations**

The foundation excavation work will require hauling of spoil off site. This will occur in tandem with deliveries for concrete and reinforcement for the foundations.

- **Concrete pours**

Concrete pours will be required throughout the works, with the size/volume of same dependant on the final structural form selected. The concrete works will be required to be carefully planned,

sequenced, and managed by the Main Contractor to ensure that works can be undertaken without undue disruption to the neighbourhood.

- **Deliveries of Prefabricated structural elements**

The selection of the chosen structural form for the roof may necessitate the delivery of prefabricated steel / timber elements. These deliveries will need to be carefully planned, sequenced, and managed by the Main Contractor to ensure that they are undertaken at the appropriate time in the works sequence so as not to cause undue disruption to the neighbourhood.

- **Vehicle Maintenance and Refuelling**

All site plant is to be inspected at the beginning of each day prior to use. Defective plant shall not be used until the defect is satisfactorily fixed. All major repair and maintenance operations will take place off site. Vehicles will never be left unattended during refuelling. Plant refuelling methodology will be overseen, and methodology agreed with by an ecological Clerk of Works.

Only dedicated trained and competent personnel will carry out refuelling operations and plant refuelling procedures shall be detailed in the contractor's method statements.

3.5.2 Contents of Traffic Management Plan

The Construction Phase Traffic Management Plan will be prepared by the appointed Contractor and shall identify:

- Primary Contact Name;
- Primary Contact Mobile Phone Number;
- Secondary Contact Name;
- Secondary Contact Mobile Phone Number.

The primary contact shall act as a Liaison Officer with the Local Authority, Gardai, local residents and businesses.

The Construction Stage Traffic Management Plan is to be formulated with reference to the DTO publications "*Traffic Management Guidelines Manual*" and the Traffic Signs Manual". The document should contain information on the following issues:

- Temporary signage (type and location);
- Temporary road markings (type and location);
- Temporary changes to existing signage and markings required to enable a road closure within the estate, if applicable;
- Location of proposed temporary traffic signals, if applicable;
- Arrangements for local access and pedestrian access;
- Proposed lighting arrangements;
- Proposals for the use of flagmen;
- Proposals to erect barriers;
- Proposals for pedestrian movements including those of mobility impaired affected by the works;
- Arrangements that will apply during the road works.

4 PRE-CONSTRUCTION ACTIVITIES

4.1 Prior to Commencement of Development

Prior to any site works commencing, the Main Contractor will carry out the following:

- 1) Prior to the mobilisation of any works onsite, an Ecological Clerk of Works (ECoW) will give a toolbox talk on the sensitivity of the work site to all workers. The ECoW will provide site-specific practical and proportionate assistance to the contractor to achieve compliance with environmental legislation and oversee the works.
- 2) Investigate / identify the exact location of and tag all existing services and utilities around and through the site with the assistance of the relevant Sligo County Council technical divisions and utility companies, where applicable.

4.2 Site Set Up, Security and Hoarding Lines

Temporary hoarding lines and site security will be set up to site boundary lines, as required for the duration of the works.

The Contractors traffic management plan will identify staging areas, delivery of materials, take account of pedestrians on the pavements north of the site adjacent to the N16 Ash Lane Road, strategy for any large concrete pours, removal of demolition waste material, traffic routes etc.

Access gates will be operated by a flagman who will divert incoming / outgoing vehicles / pedestrians and general traffic as necessary.

A number of surveys will be required prior to works commencing on site. This includes:

- Baseline readings for noise, vibration, dust etc in advance of the establishment of monitoring regime and action of same;
- Surveys to identify toxic/hazardous materials which may be present on site.

5 Demolition

The existing residential units, paved areas adjacent, front boundary walls as indicated on drawing No S603-OCSC-XX-XX-DR-C-0605 are to be demolished and removed off-site. Refer to Figure 10 showing and extract from the demolition drawing:



Figure 10 – Demolition Works Plan.

6 FOUNDATION & SUB-STRUCTURE WORKS

6.3 Overview

A detailed site investigation of the entire site has been undertaken to inform the proposed foundation solution – refer to Figures 11 & 12:

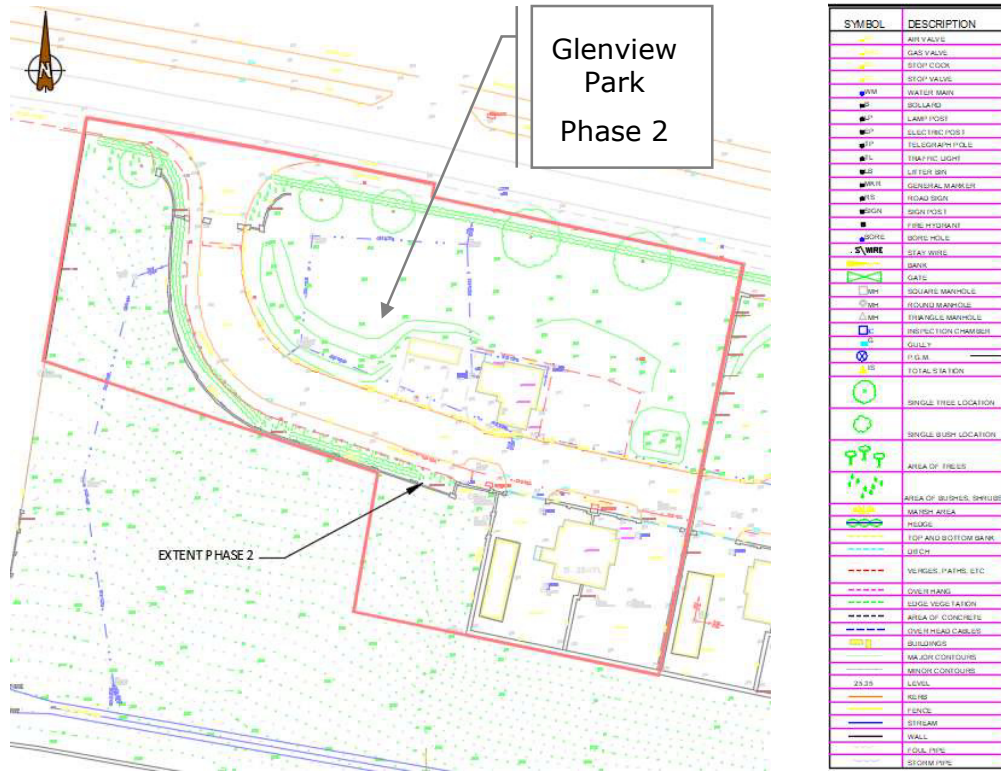

Figure 11 – Topographical Site Survey

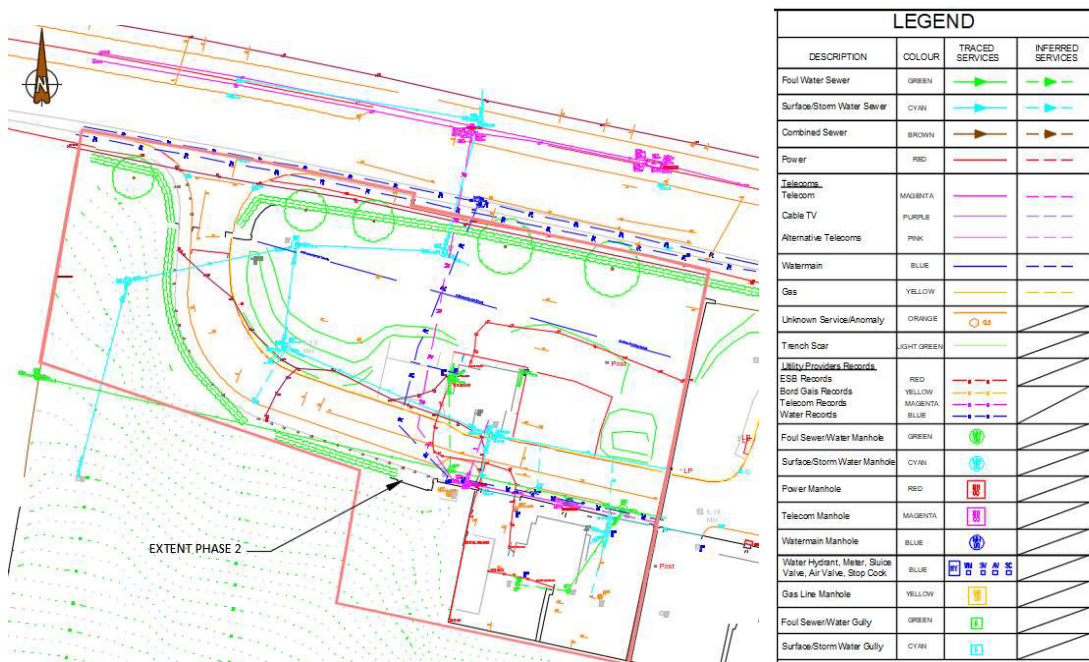

Figure 12 – GPR Site Survey

6.4 Foundations

The proposed foundations will be constructed using, strip foundations, piled foundations, and retaining walls on compacted fill onto approved bearing stratum. Refer to Figure 13 showing proposed works layout.

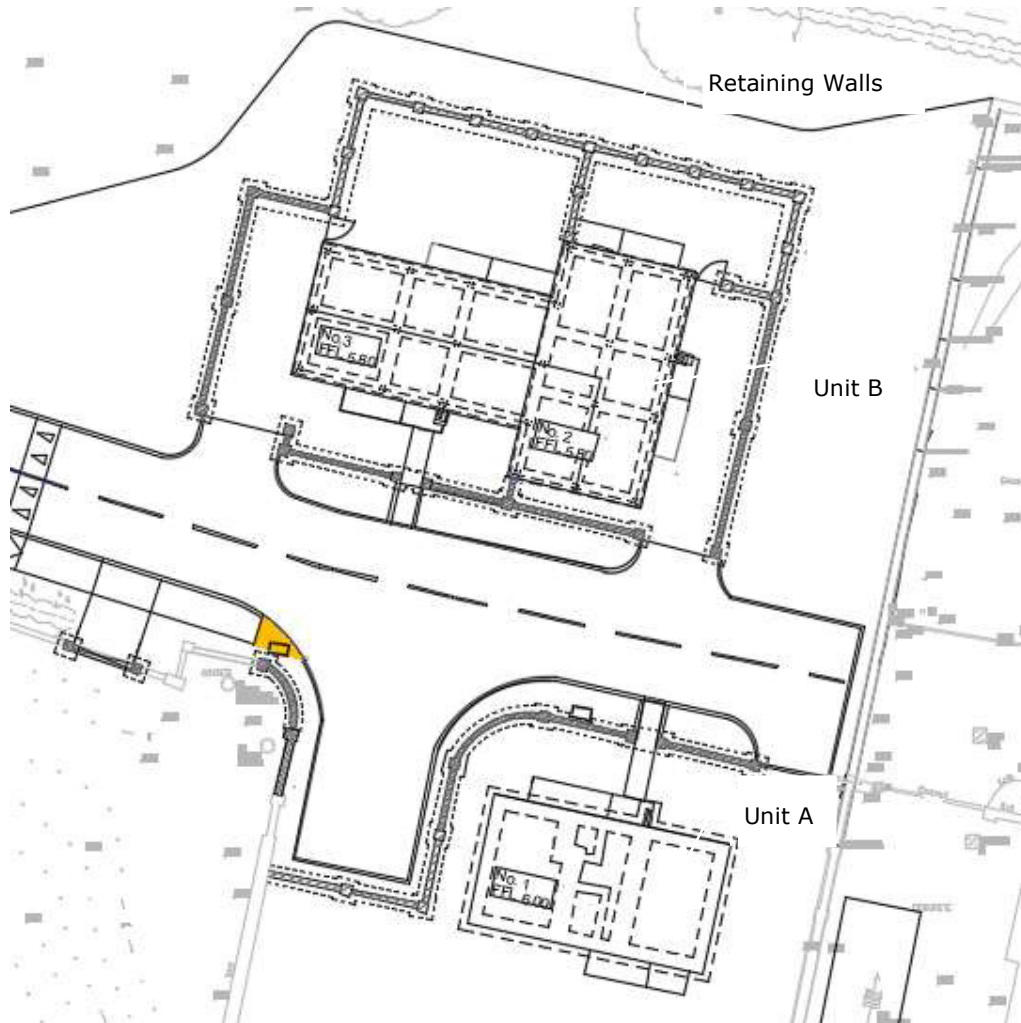

Figure 13 – Proposed Foundation Layout

6.5 Concrete Foundations (Strip Footings)

The actions required to form the concrete raft foundations and Strip Footing will consist of:

- Excavation of materials to approved formation.
- Installation of formwork.
- Placement of reinforcement.
- Pouring off concrete.
- Removing formwork when concrete is cured.

The following Figures 14 & 15 show typical foundation details and build-up of sub-base and capping materials.

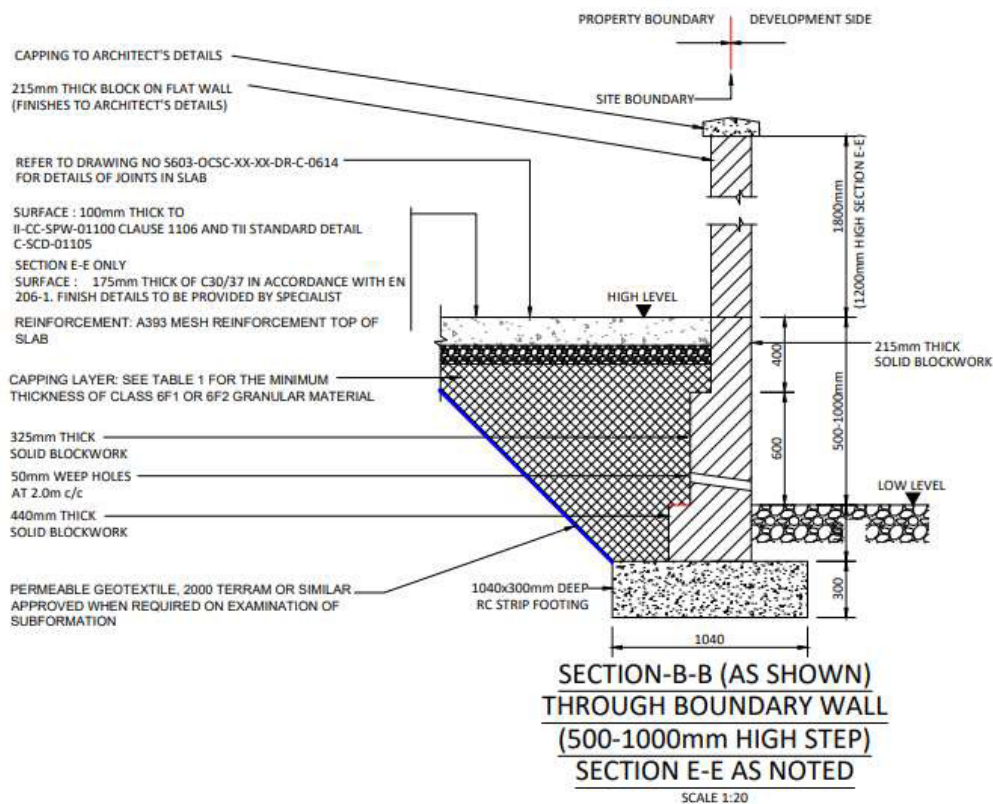

Figure 14 – Typical Section through Strip Footing for Block Retaining Walls

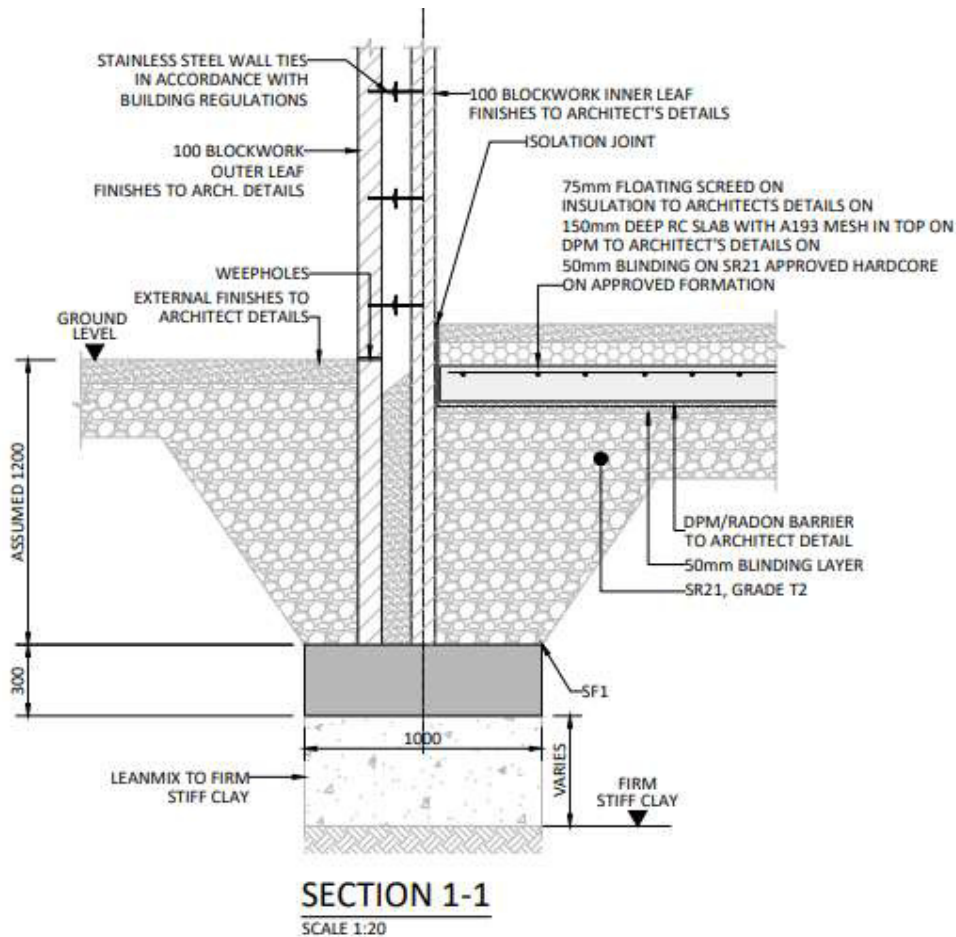

Figure 15 – Typical Section through Strip Foundation for new Housing Unit A

Where concrete is delivered to site only chute cleaning will be permitted with the minimal volume of water possible. No washing of any plant used in concrete transport will be allowed on site. All foundation bases are to be free of any standing water prior to concrete pours with provision of plastic (or similar) covering material to be on standby in the event of sudden rainfall. Planned concrete pours are to be coordinated with weather forecasting. Refer to section 3.3.10 for ground water and surface water control.

6.6 Piled Foundation

Precast concrete piles are designed by specialist designer and are reinforced to withstand driving stresses. The piles are driven into the soil, pushing an equal volume of soil sideways and compacting a zone around the pile, increasing its bearing capacity. Most piling rigs are track mounted and are specialist plant items, built to install one type of pile. Driven piles are hammered, jacked, or vibrated into the ground using a percussion hammer, hydraulic driver or rams or diesel-powered vibratory drivers used to reduce surrounding ground resistance and allow the pile to slide into the ground.

Following figure shows a pile foundation detail and suspended hollow core slab.

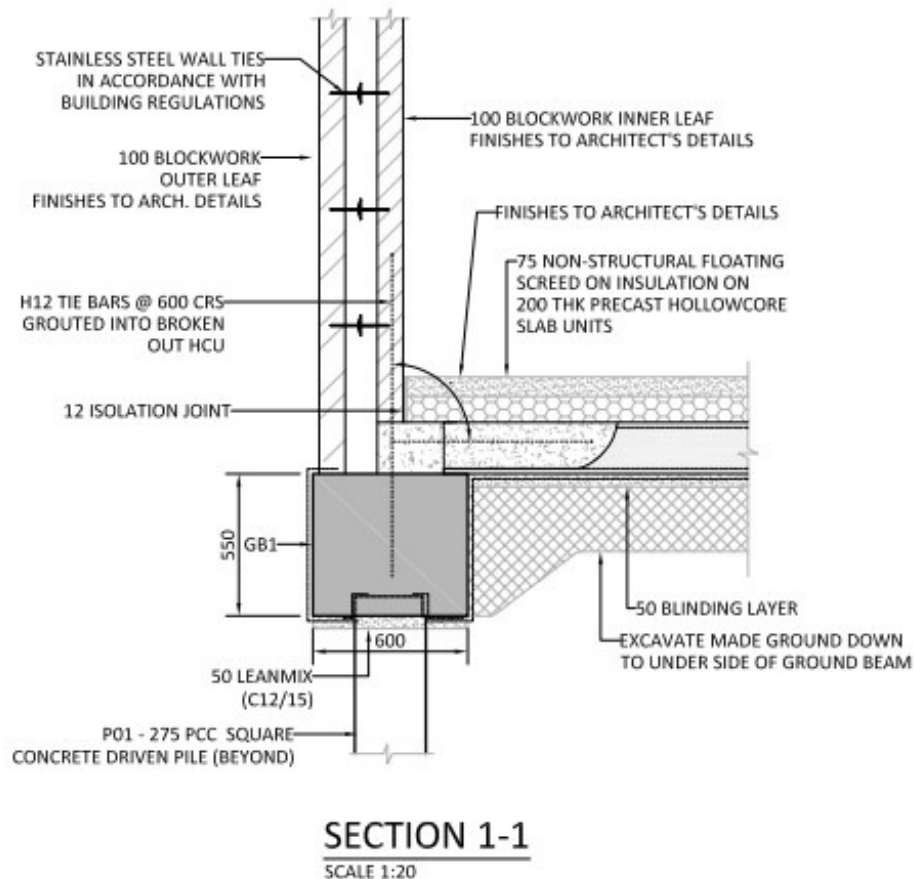

Figure 16 – Typical Section through Pile Foundation for new Housing Unit B

6.7 Storm Water Attenuation Tank

All proposed developments must ensure that a comprehensive sustainable urban drainage system, SuDS, is incorporated into the development. SuDS requires that post development run-off rates be maintained at equivalent, or lower, levels than pre-development levels. Thus, the development must be able to retain, within its boundaries, storm water volumes from extreme storm events up to a 1 in 100-year storm event, more commonly expressed as a 1.0% AEP with additional 20% for climate change included (Annual Exceedance Probability). Any new development must have the physical capacity to retain storm water volumes as directed under the GSDS and, if necessary, release these attenuated surface water volumes to an outfall at a controlled flow rate. A further component of the SuDS protocols is to increase the overall water quality of surface water runoff before it enters a natural watercourse or into a public sewer, which ultimately discharges to a water body. This is to ensure the highest possible standard of storm water quality.

The proposed surface water drainage network incorporates a variety of SuDS features to reduce flood risks and improve water quality. Details of the proposed Storm Water network and attenuation tank are given on drawing No S603-OCSC-XX-XX-DR-C-0620. Refer to Figure 16 for proposed layout of the Storm Water Network and Attenuation Tank System.

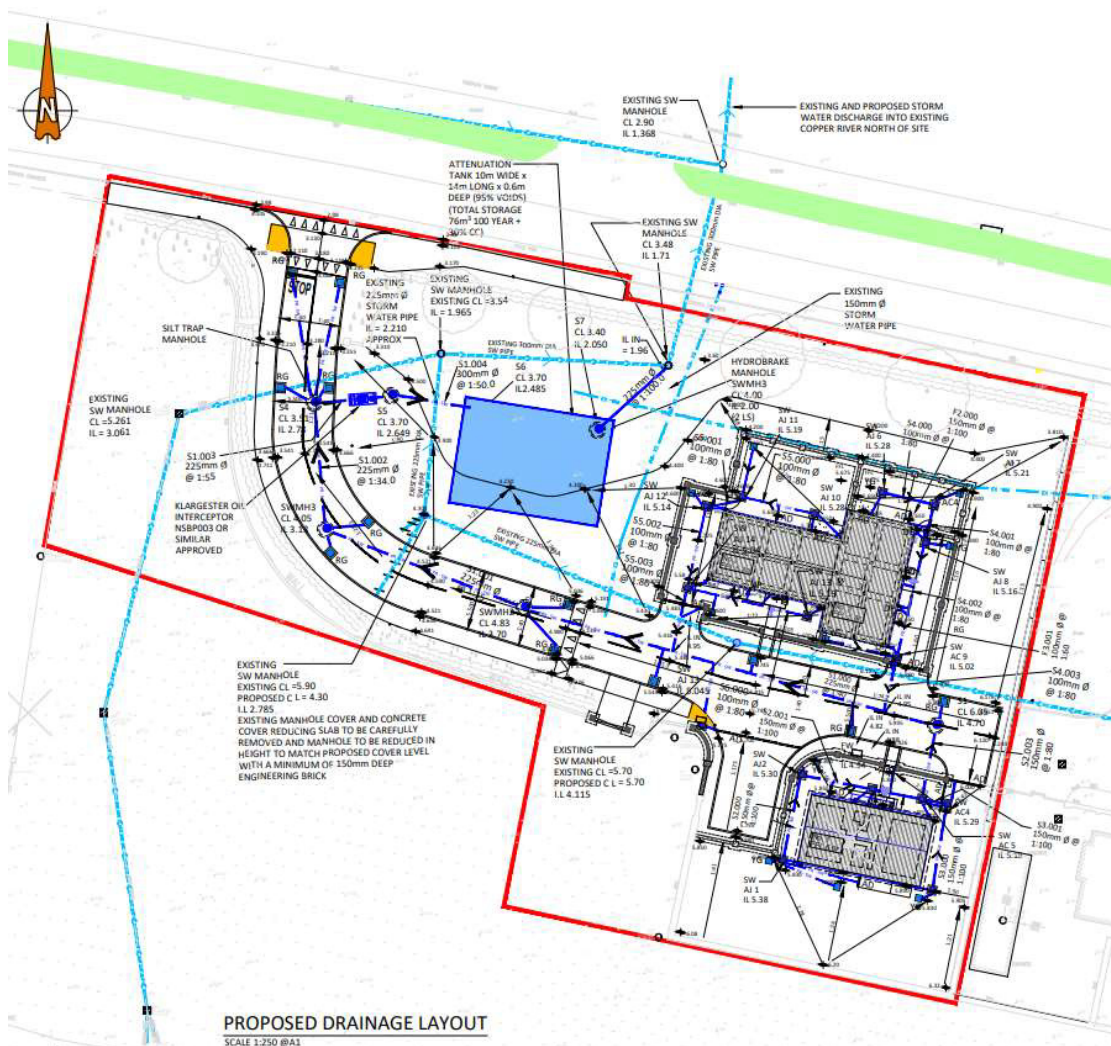

Figure 16 – Proposed Storm Water Network and Attenuation Tank.

Storm water is to be attenuated on site and discharged into the existing local authority stormwater pipe network on site via a Hydrobrake limiting flow to 2l/s. Refer to Figure 17 for proposed Attenuation Tank System.

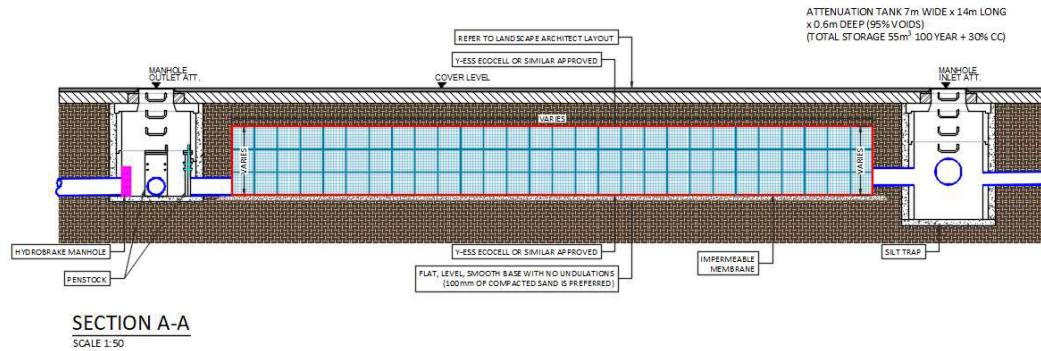

Figure 17 – Typical Section Attenuation Tank System

The actions required to install the Storm Water Attenuation tank will consist of:

- Excavation of materials to approved formation.
- Placement of sand blinding bedding layer
- Installation of Modular Attenuation Units wrapped in non-impermeable membrane and including granular bedding, clause 505 and distribution pipe(s).
- Backfill sides with granular backfill material Class 6N.
- Backfill over top of tank using suitable granular fill and clat material.
- Refer to Figure 18 for typical installation and construction details.

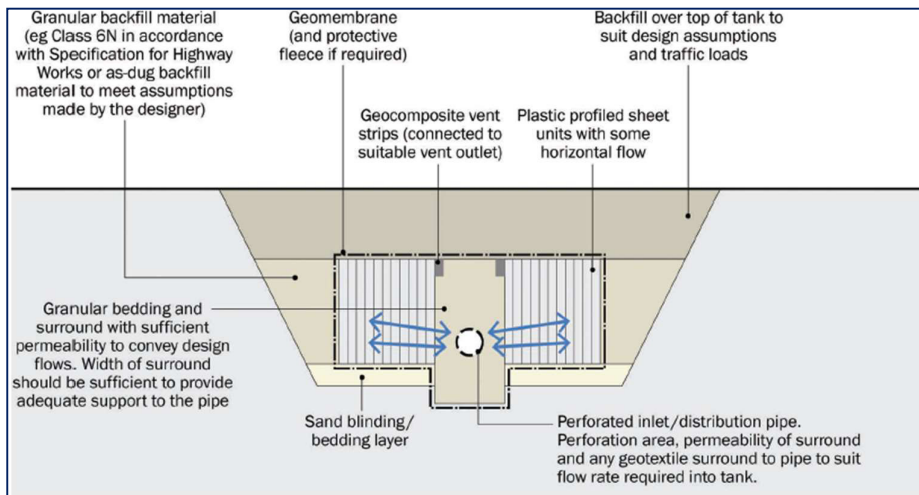

Figure 18: Typical Section of Geocellular System (CIRIA C753)

7 SITEWORKS

7.1 Overview

The siteworks for the proposed development will entail the installation of all required below ground services adjacent to the proposed housing units and road improvement works as well as the proposed landscaping works.

7.2 Site Services

A variety of services will be required to be constructed to provide functionality to the proposed development. These services will include items such drainage, water supply & power supply. Exact requirements to be confirmed.

The site services works are likely to proceed following completion of the foundations and will continue throughout the superstructure works.

The site services work will generally involve where required:

- Excavation of services trench;
- Placing of bedding as required for each service;
- Placing of service pipe/conduit within the trench;
- Placing of warning tape as required by each utility;
- Backfilling of trench.

7.3 Hard & Soft Landscaping

The externals to the proposed housing units and road works are made up of a number of differing soft and hard landscaping finishes. Refer to Landscape Architect layout.

The soft finishes may include:

- Grassed areas;

The hard landscaping may include:

- Pathways;
- Communal areas;

The hard landscaping works for the site are there to enhance the overall design, compliment the soft finishes and allow for pedestrian to and around the proposed works. The hard and soft landscaping works will be undertaken following the completion of the main elements of construction in accordance with Landscape Architect details.

The soft landscaping works will involve:

- Scrapping of existing topsoil to allow natural recolonisation and concurrently applying native Irish seed. This habitat will require low maintenance into the future: two moving session a year spring and autumn.
- Native trees and shrubs sourced in Ireland to enhance biodiversity. Planting to follow the IW Document No I1-AMT-GL-021 Biodiversity Guidance for Irish Water which will help deliver maximum benefit for biodiversity through the project delivery.
- Seeding of grass;
- Placing of furniture and fittings.

The hard landscaping works will involve:

- Placing and compacting of hardcore sub-base;
- Placing of furniture and fittings.

8 OUTLINE CONSTRUCTION PROGRAMME

8.1 Overview

At this stage of carrying out this assessment, a contractor has not yet been appointed to undertake the construction works. However, the information and parameters within this document will form part of any construction documentation issued and the appointed contractor will be required to comply with the outline methodology described.

This statement describes the anticipated programme of construction works and the key activities that will be undertaken on the site in relation to the development.

As part of the construction process the main contractors will be required to submit a statement demonstrating how they will comply with the Management Plan and, after appointment, provide detailed documentation to demonstrate this compliance.

It is envisaged that construction works would commence in late 2023 with a completion date of late 2024. Below ground Works to be planned to coincide with low to no rainfall periods.

A full set of drawings (A3 not scale) for the existing and proposed works to Glenview Park Works is provided in Appendix A for ease of reference.

Tom Duggan

AENG MIEI MICS

FOR OCSC MULTIDISCIPLINARY CONSULTING ENGINEERS

Appendix A

Glenview Park Phase 2

A3 Drawings (N.T.S)

PROPOSED DEVELOPMENT AT ASH LANE SLIGO

PHASE 2 GLENVIEW PARK

TENDER DRAWINGS

CIVIL ENGINEERING DRAWINGS

AUGUST 2023



OCSC
O'CONNOR | SUTTON | CRONIN
Multidisciplinary
Consulting Engineers

OCSC

O'CONNOR . SUTTON . CRONIN
MULTIDISCIPLINARY CONSULTING ENGINEERS
Civil / Structural / Environmental / Mechanical/Electrical / Sustainability
Galway Office: Technology House, Galway Technology Park,
Parkmore, Galway.
Tel: +353 (0)91 771360 Web: www.ocsc.ie
Dublin · London · Belfast · Galway · Cork · Birmingham

S603-OCSC-XX-XX-DR-C-0600-D2-P01

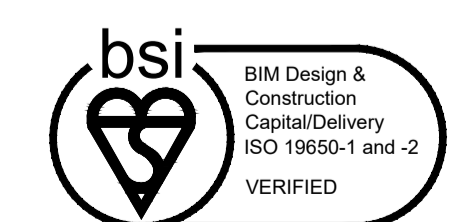
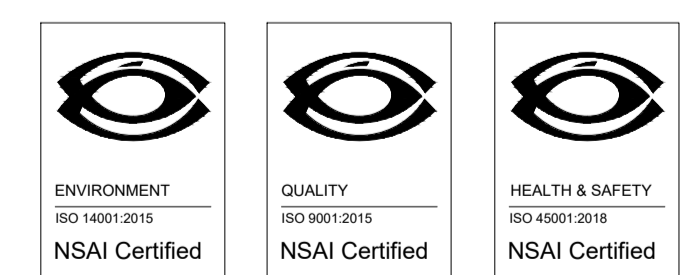

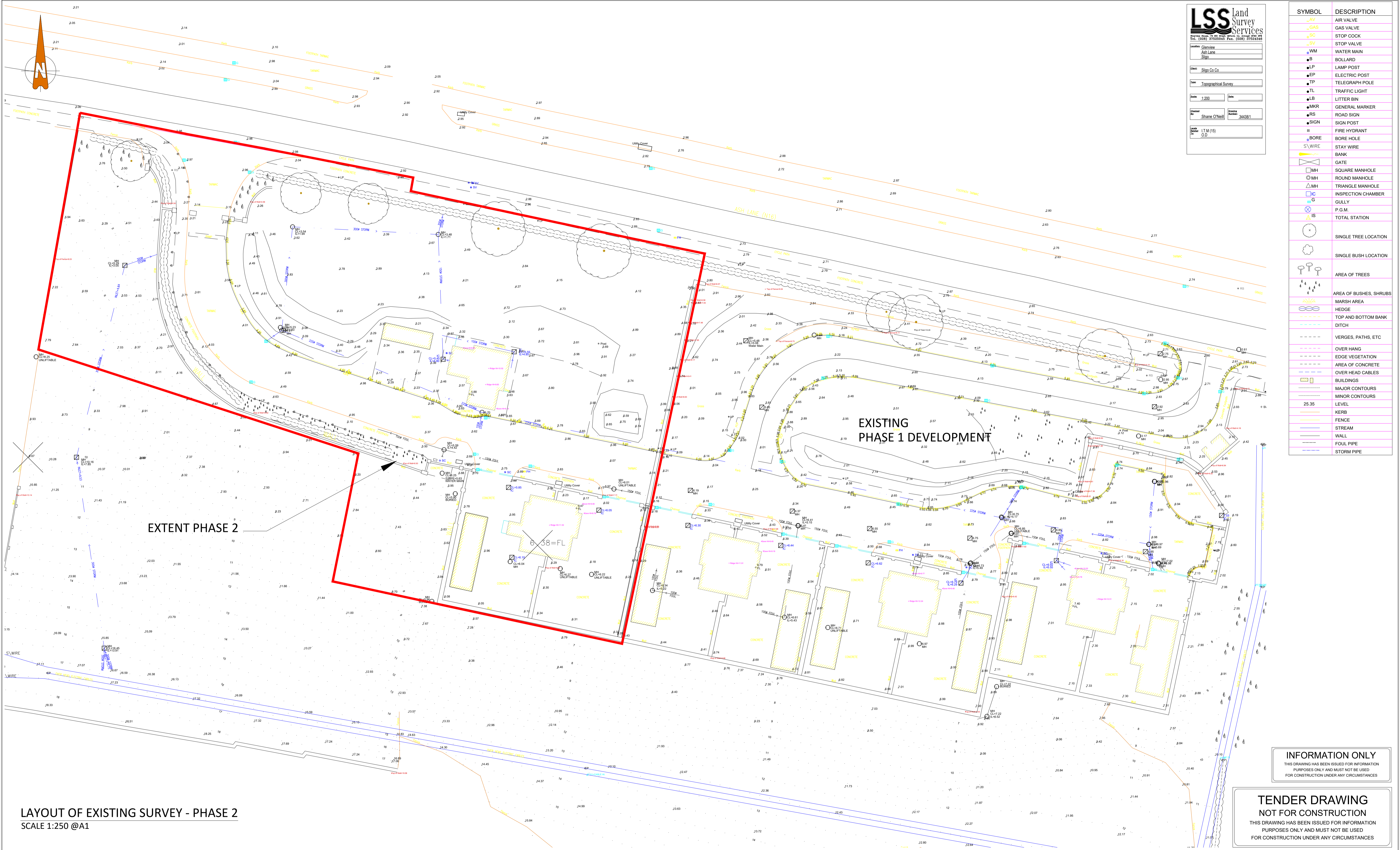

LSS Land Survey Services
 LSS Land Survey Services
 2nd Floor, Technology House,
 Galway Technology Park, Parkmore,
 Galway.
 Tel: (091) 310000 Fax: (091) 3100444
 Email: info@lss.ie
 Website: www.lss.ie
 Project: Sligo Co. Co.
 Title: Topographical Survey
 Scale: 1:200 Date:
 Client: Sligo County Council
 Project: ASH Lane Group Housing
 Title: EXISTING SITE SURVEY PHASE 2
 Scale: 1:250 Date:
 Client: Sligo County Council
 Project: ASH Lane Group Housing
 Title: EXISTING SITE SURVEY PHASE 2

| SYMBOL | DESCRIPTION |
|--------|------------------------|
| AV | AIR VALVE |
| GV | GAS VALVE |
| SC | STOP COCK |
| SV | STOP VALVE |
| WM | WATER MAIN |
| B | BOLLARD |
| LP | LAMP POST |
| EP | ELECTRIC POST |
| TP | TELEGRAPH POLE |
| TL | TRAFFIC LIGHT |
| LB | LITTER BIN |
| MKR | GENERAL MARKER |
| RS | ROAD SIGN |
| SIGN | SIGN POST |
| IF | FIRE HYDRANT |
| BORE | BORE HOLE |
| S.WIRE | STAY WIRE |
| GATE | GATE |
| MH | SQUARE MANHOLE |
| MH | ROUND MANHOLE |
| MH | TRIANGLE MANHOLE |
| IC | INSPECTION CHAMBER |
| G | GULLY |
| P.G.M. | P.G.M. |
| T.S. | TOTAL STATION |
| ST | SINGLE TREE LOCATION |
| SB | SINGLE BUSH LOCATION |
| AT | AREA OF TREES |
| AS | AREA OF BUSHES, SHRUBS |
| MA | MARSH AREA |
| H | HEDGE |
| T&B | TOP AND BOTTOM BANK |
| D | DITCH |
| V | VERGES, PATHS, ETC |
| OH | OVER HANG |
| EV | EDGE VEGETATION |
| AC | AREA OF CONCRETE |
| OC | OVER HEAD CABLES |
| B | BUILDINGS |
| MC | MAJOR CONTOURS |
| NC | MINOR CONTOURS |
| 25.35 | LEVEL |
| K | KERB |
| F | FENCE |
| S | STREAM |
| W | WALL |
| FP | FOUL PIPE |
| SP | STORM PIPE |

EXTENT PHASE 2

EXISTING PHASE 1 DEVELOPMENT

LAYOUT OF EXISTING SURVEY - PHASE 2
 SCALE 1:250 @A1

INFORMATION ONLY
 THIS DRAWING HAS BEEN ISSUED FOR INFORMATION PURPOSES ONLY AND MUST NOT BE USED FOR CONSTRUCTION UNDER ANY CIRCUMSTANCES

TENDER DRAWING
 NOT FOR CONSTRUCTION
 THIS DRAWING HAS BEEN ISSUED FOR INFORMATION PURPOSES ONLY AND MUST NOT BE USED FOR CONSTRUCTION UNDER ANY CIRCUMSTANCES

- FOR SETTING OUT REFER TO ARCHITECT'S DRAWINGS.
- THIS DRAWING TO BE READ IN CONJUNCTION WITH ALL OTHER ARCHITECTURAL AND ENGINEERING DRAWINGS AND ALL OTHER RELEVANT DRAWINGS AND SPECIFICATIONS.
- DO NOT SCALE THIS DRAWING. USE FIGURED DIMENSIONS ONLY.
- NO PART OF THIS DOCUMENT MAY BE REPRODUCED OR TRANSMITTED IN ANY FORM OR STORED IN ANY RETRIEVAL SYSTEM OF ANY NATURE WITHOUT THE WRITTEN PERMISSION OF O'CONNOR SUTTON CRONIN AS COPYRIGHT HOLDER EXCEPT AS AGREED FOR USE ON THE PROJECT FOR WHICH THE DOCUMENT WAS ORIGINALLY ISSUED.

| Rev No. | Date | Revision Note | Drn by | Chkd by |
|---------|----------|------------------------------------|--------|---------|
| P01 | 02.02.23 | FOR INFORMATION | TD | TOD |
| P02 | 24.06.23 | REDLINE BOUNDARY UPDATED | AD | TD |
| P03 | 16.08.23 | ISSUED FOR TENDER INFORMATION ONLY | AD | TD |

| Rev No. | Date | Revision Note | Drn by | Chkd by |
|---------|------|---------------|--------|---------|
| | | | | |
| | | | | |
| | | | | |
| | | | | |
| | | | | |
| | | | | |
| | | | | |
| | | | | |
| | | | | |
| | | | | |
| | | | | |
| | | | | |
| | | | | |

SLIGO COUNTY COUNCIL

OCSC
O'CONNOR | SUTTON | CRONIN
Multidisciplinary Consulting Engineers

2nd Floor, Technology House,
Galway Technology Park,
Parkmore,
Galway.

TEL +353 (0)91 771360

e: galway@ocsc.ie
w: www.ocsc.ie

Dublin | London | Belfast | Galway | Cork | Birmingham

Client: **SLIGO COUNTY COUNCIL**
 Project: **ASH LANE GROUP HOUSING**
 Title: **EXISTING SITE SURVEY PHASE 2**

| | | | | | | | | |
|------|------------|------|-------|------|------|--------|--------|----------|
| Code | Originator | Zone | Level | Type | Role | Number | Status | Revision |
| S603 | OCSC | XX | XX | DR | C | 0601 | D2 | P03 |

Date: JAN '23 Scale: 1:250 @ A1 Drn by: AD Chkd by: TD Aprvd by:

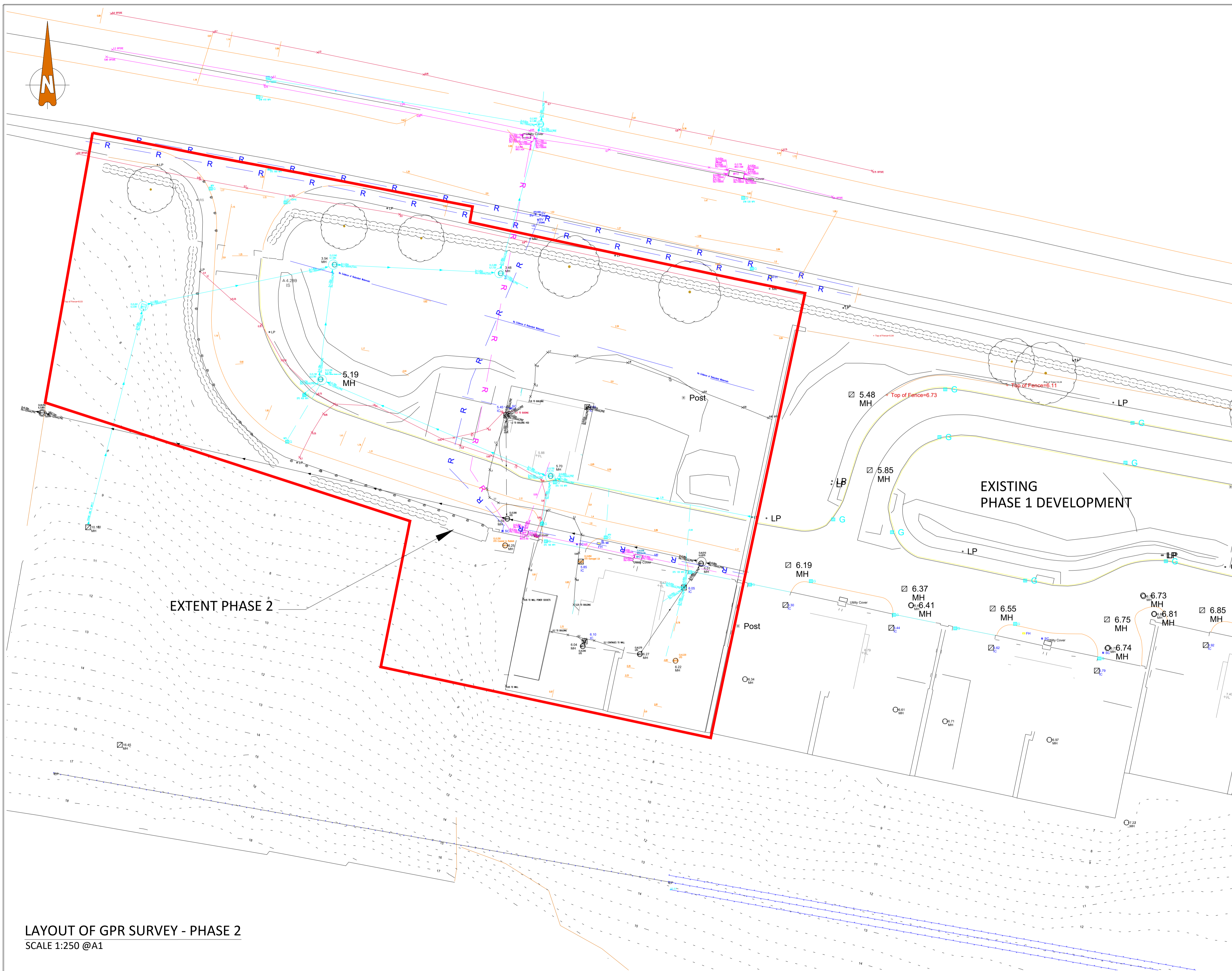

LEGEND

| DESCRIPTION | COLOUR | TRACED SERVICES | INFERRED SERVICES |
|--|-------------|-----------------|-------------------|
| Foul Water Sewer | GREEN | —▶— | —▶— |
| Surface/Storm Water Sewer | CYAN | —▶— | —▶— |
| Combined Sewer | BROWN | —▶— | —▶— |
| Power | RED | — | --- |
| Telecoms | | | |
| Telecom | MAGENTA | — | --- |
| Cable TV | PURPLE | — | --- |
| Alternative Telecoms | PINK | — | --- |
| Watermain | BLUE | — | --- |
| Gas | YELLOW | — | --- |
| Unknown Service/Anomaly | ORANGE | ○ 0.5 | |
| Trench Scar | LIGHT GREEN | — | |
| Utility Providers Records | | | |
| ESB Records | RED | --- | |
| Bord Gais Records | YELLOW | --- | |
| Telecom Records | MAGENTA | --- | |
| Water Records | BLUE | --- | |
| Foul Sewer/Water Manhole | GREEN | ⊗ | |
| Surface/Storm Water Manhole | CYAN | ⊗ | |
| Power Manhole | RED | ⊗ | |
| Telecom Manhole | MAGENTA | ⊗ | |
| Watermain Manhole | BLUE | ⊗ | |
| Water Hydrant, Meter, Sluice Valve, Air Valve, Stop Cock | BLUE | ⊗ | |
| Gas Line Manhole | YELLOW | ⊗ | |
| Foul Sewer/Water Gully | GREEN | ⊗ | |
| Surface/Storm Water Gully | CYAN | ⊗ | |

NOTES:

- Utility survey carried out with RF & GPR equipment.
- RF = RD8000 Transmitter & Receiver.
- UTT denotes unable to Trace, UTO denotes unable to Open
- GPR = Ground Penetrating Radar - Mala 100 Mhz, 250 Mhz & 500 Mhz.
- Unknown voltage on electric cables.
- Dia. 300mm denotes the diameter of the pipe.
- 0.5 denotes depth in metres below ground level to top of pipe.
- Survey carried out in February 2023.
- R denotes sections of services taken from records.
- D = Depth to Pipe, DTF = Depth to Floor, DTS = Depth to Silt, BOC = Bottom Of Chamber.
- Where Invert Levels are shown adjacent to MHs, IC's etc. are to the invert of the lowest pipe/duct within the manhole. There may be further pipes/ducts within the MH which are located closer to ground level as per the depths marked on individual pipes/ducts. Care should be taken as higher level ducts may contain live electrical cables.

Disclaimer:
The information on this drawing is a general guide only and the accuracy thereof cannot be guaranteed. No liability is accepted for any discrepancy, omission or deviation from the actual subsurface location or depth to underground utilities.

GPR - Utility Survey

Unit 1
Enterprise, Technology & Innovation Centre,
Clonmore Business Park,
Mullingar, Co Westmeath.

T: 01 2542680
E: info@scantech.ie
www.scantech.ie

Client: Causeway Geotech Ltd

Project Title: GPR Survey at Glenview, Sligo.

Drawing Title: Underground Services Layout

Date: 21st February 2023 Drawn By: R.G
Scale: 1/200 on A1 Checked: D.T
Drawing No: SGL-23031-01_01 Revision:

LAYOUT OF GPR SURVEY - PHASE 2

SCALE 1:250 @A1

- FOR SETTING OUT REFER TO ARCHITECT'S DRAWINGS.
- THIS DRAWING TO BE READ IN CONJUNCTION WITH ALL OTHER ARCHITECTURAL AND ENGINEERING DRAWINGS AND ALL OTHER RELEVANT DRAWINGS AND SPECIFICATIONS.
- DO NOT SCALE THIS DRAWING. USE FIGURED DIMENSIONS ONLY.
- NO PART OF THIS DOCUMENT MAY BE REPRODUCED OR TRANSMITTED IN ANY FORM OR STORED IN ANY RETRIEVAL SYSTEM OF ANY NATURE WITHOUT THE WRITTEN PERMISSION OF O'CONNOR SUTTON CRONIN AS COPYRIGHT HOLDER EXCEPT AS AGREED FOR USE ON THE PROJECT FOR WHICH THE DOCUMENT WAS ORIGINALLY ISSUED.

| Rev No. | Date | Revision Note | Drn by | Chkd by |
|---------|----------|------------------------------------|--------|---------|
| P01 | 23.02.23 | FOR INFORMATION | TD | TOD |
| P02 | 24.06.23 | REDLINE BOUNDARY UPDATED | AD | TD |
| P03 | 16.08.23 | ISSUED FOR TENDER INFORMATION ONLY | AD | TD |

| Rev No. | Date | Revision Note | Drn by | Chkd by |
|---------|------|---------------|--------|---------|
| | | | | |

TENDER DRAWING
NOT FOR CONSTRUCTION
THIS DRAWING HAS BEEN ISSUED FOR INFORMATION PURPOSES ONLY AND MUST NOT BE USED FOR CONSTRUCTION UNDER ANY CIRCUMSTANCES

INFORMATION ONLY
THIS DRAWING HAS BEEN ISSUED FOR INFORMATION PURPOSES ONLY AND MUST NOT BE USED FOR CONSTRUCTION UNDER ANY CIRCUMSTANCES

SLIGO COUNTY COUNCIL
COMMUNITY DEVELOPMENT DIVISION

OCSC
O'CONNOR | SUTTON | CRONIN
Multiprofessional Consulting Engineers

2nd Floor, Technology House,
Galway Technology Park,
Parkmore,
Galway.

TEL +353 (0)91 771360

e: galway@ocsc.ie
w: www.ocsc.ie

Dublin | London | Belfast | Galway | Cork | Birmingham

Client: **SLIGO COUNTY COUNCIL**
Project: **ASH LANE GROUP HOUSING**

Title: **GPR SURVEY PHASE 2**

Code | Originator | Zone | Level | Type | Role | Number | Status | Revision
S603 · OCSC · XX · XX · DR · C · 0602 · D2 · P03

Date: FEB '23 Scale: 1:250 @ A1 Drn by: AD Chkd by: TD Aprvd by:

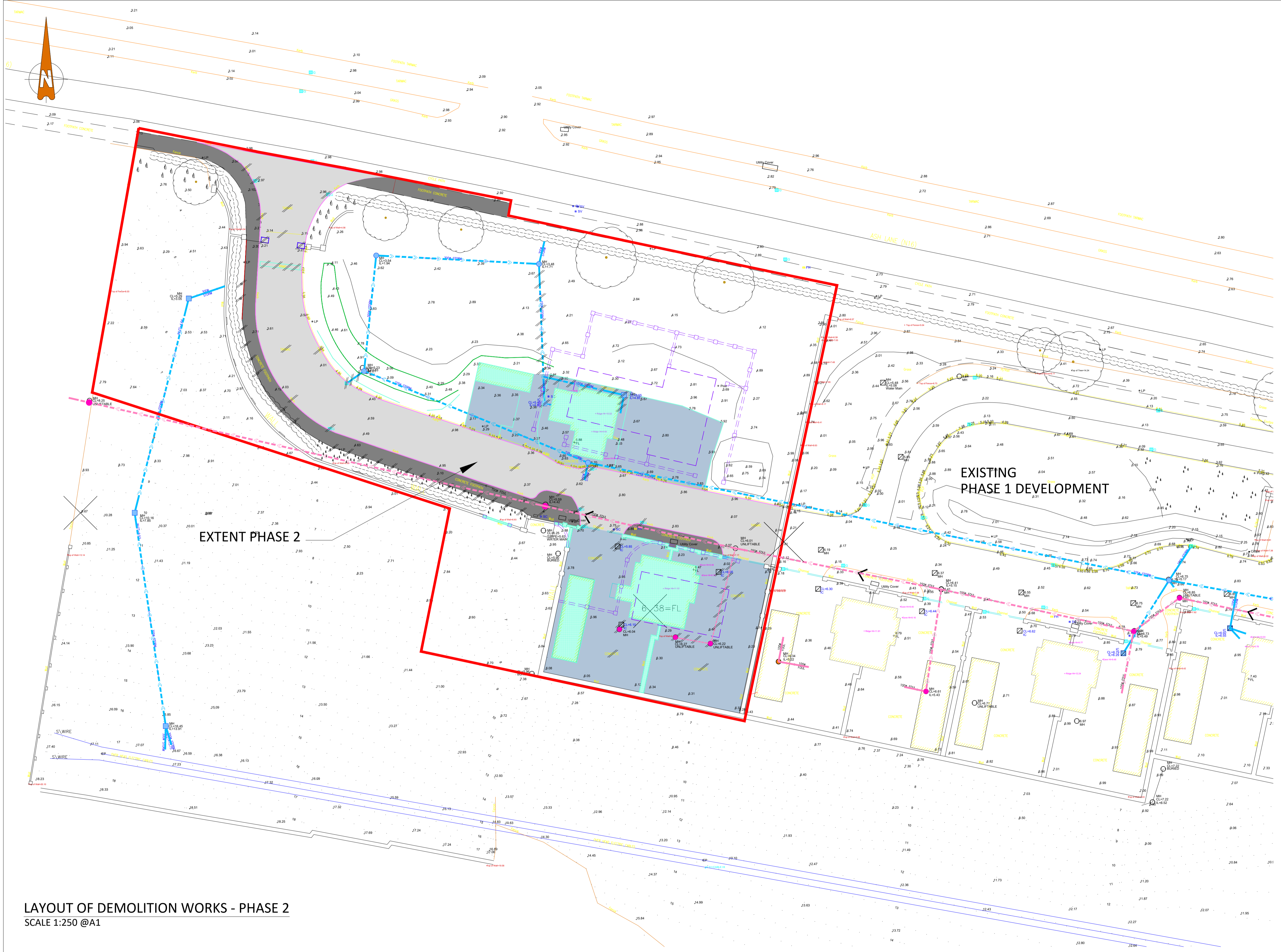

| LEGEND | |
|---------------------------------|---|
| EXISTING FOUL DRAINAGE NETWORK | |
| | EXISTING FOUL DRAINAGE PIPES TO BE RETAINED |
| | EXISTING FOUL DRAINAGE MANHOLES TO BE RETAINED |
| | EXISTING FOUL DRAINAGE PIPES TO BE DEMOLISHED |
| | EXISTING FOUL DRAINAGE MANHOLES TO BE DEMOLISHED |
| EXISTING STORM DRAINAGE NETWORK | |
| | EXISTING STORM DRAINAGE PIPES TO BE RETAINED |
| | EXISTING STORM DRAINAGE MANHOLES TO BE RETAINED |
| | EXISTING STORM DRAINAGE AJ/IC TO BE DEMOLISHED |
| | EXISTING STORM DRAINAGE PIPES TO BE DEMOLISHED |
| | EXISTING STORM DRAINAGE MANHOLES TO BE DEMOLISHED |
| | EXISTING STORM DRAINAGE AJ/IC TO BE DEMOLISHED |
| | PROPOSED BUILDING DEMOLITION WORKS - WALLS AND HOUSES |
| | EXTENT OF EXISTING KERBING TO BE DEMOLISHED |
| | EXTENT OF EXISTING BERM TO BE DEMOLISHED |
| | EXTENT OF EXISTING ROAD TO DEMOLISHED TO A DEPTH OF 100mm MINIMUM |
| | EXTENT OF EXISTING FOOTPATH TO DEMOLISHED TO A DEPTH OF 100mm MINIMUM |
| | EXTENT OF EXISTING HARD SURFACE TO EXISTING UNITS TO DEMOLISHED TO A DEPTH OF 100mm MINIMUM |
| | PROPOSED NEW HOUSING UNITS AND ADDITIONAL BOUNDARY WALLS |
| | EXISTING GATE PILLARS TO BE DEMOLISHED |
| | EXISTING GULLIES TO BE DEMOLISHED INCLUDING ALL ASSOCIATED PIPEWORK TO EXISTING STORM WATER NETWORK |
| | EXISTING BOLLARDS TO BE REMOVED INCLUDING FOUNDATIONS |
| | EXISTING ROAD RAMP TO BE REMOVED |

LAYOUT OF DEMOLITION WORKS - PHASE 2
SCALE 1:250 @A1

TENDER DRAWING
NOT FOR CONSTRUCTION
THIS DRAWING HAS BEEN ISSUED FOR INFORMATION PURPOSES ONLY AND MUST NOT BE USED FOR CONSTRUCTION UNDER ANY CIRCUMSTANCES

- FOR SETTING OUT REFER TO ARCHITECT'S DRAWINGS.
- THIS DRAWING TO BE READ IN CONJUNCTION WITH ALL OTHER ARCHITECTURAL AND ENGINEERING DRAWINGS AND ALL OTHER RELEVANT DRAWINGS AND SPECIFICATIONS.
- DO NOT SCALE THIS DRAWING. USE FIGURED DIMENSIONS ONLY.
- NO PART OF THIS DOCUMENT MAY BE REPRODUCED OR TRANSMITTED IN ANY FORM OR STORED IN ANY RETRIEVAL SYSTEM OF ANY NATURE WITHOUT THE WRITTEN PERMISSION OF O'CONNOR SUTTON CRONIN AS COPYRIGHT HOLDER EXCEPT AS AGREED FOR USE ON THE PROJECT FOR WHICH THE DOCUMENT WAS ORIGINALLY ISSUED.

| Rev No. | Date | Revision Note | Drn by | Chkd by |
|---------|----------|----------------------------------|--------|---------|
| P01 | 02.02.23 | TD | TOD | |
| P02 | 23.02.23 | ADDITIONAL DEMOLITION AS BUBBLED | TD | TOD |
| P03 | 24.06.23 | REDLINE BOUNDARY UPDATED | AD | TD |
| P04 | 16.08.23 | ISSUED FOR TENDER | AD | TD |

| Rev No. | Date | Revision Note | Drn by | Chkd by |
|---------|------|---------------|--------|---------|
| | | | | |
| | | | | |
| | | | | |

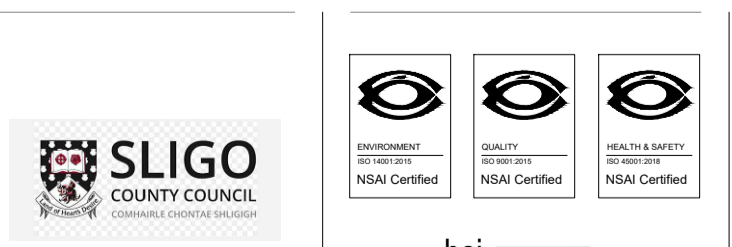

2nd Floor, Technology House,
Galway Technology Park,
Parkmore,
Galway.
TEL +353 (0)91 771360
e: galway@ocsc.ie
w: www.ocsc.ie
Dublin | London | Belfast | Galway | Cork | Birmingham



Client: SLIGO COUNTY COUNCIL
Project: ASH LANE GROUP HOUSING
Title: PROPOSED DEMOLITION WORKS
Code | Originator | Zone | Level | Type | Role | Number | Status | Revision
S603 - OCSC - XX - XX - DR - C - 0605 | D2 | P04
Date: JAN '23 Scale: 1:250 @ A1 Drn by: AD Chkd by: TD Aprvd by:

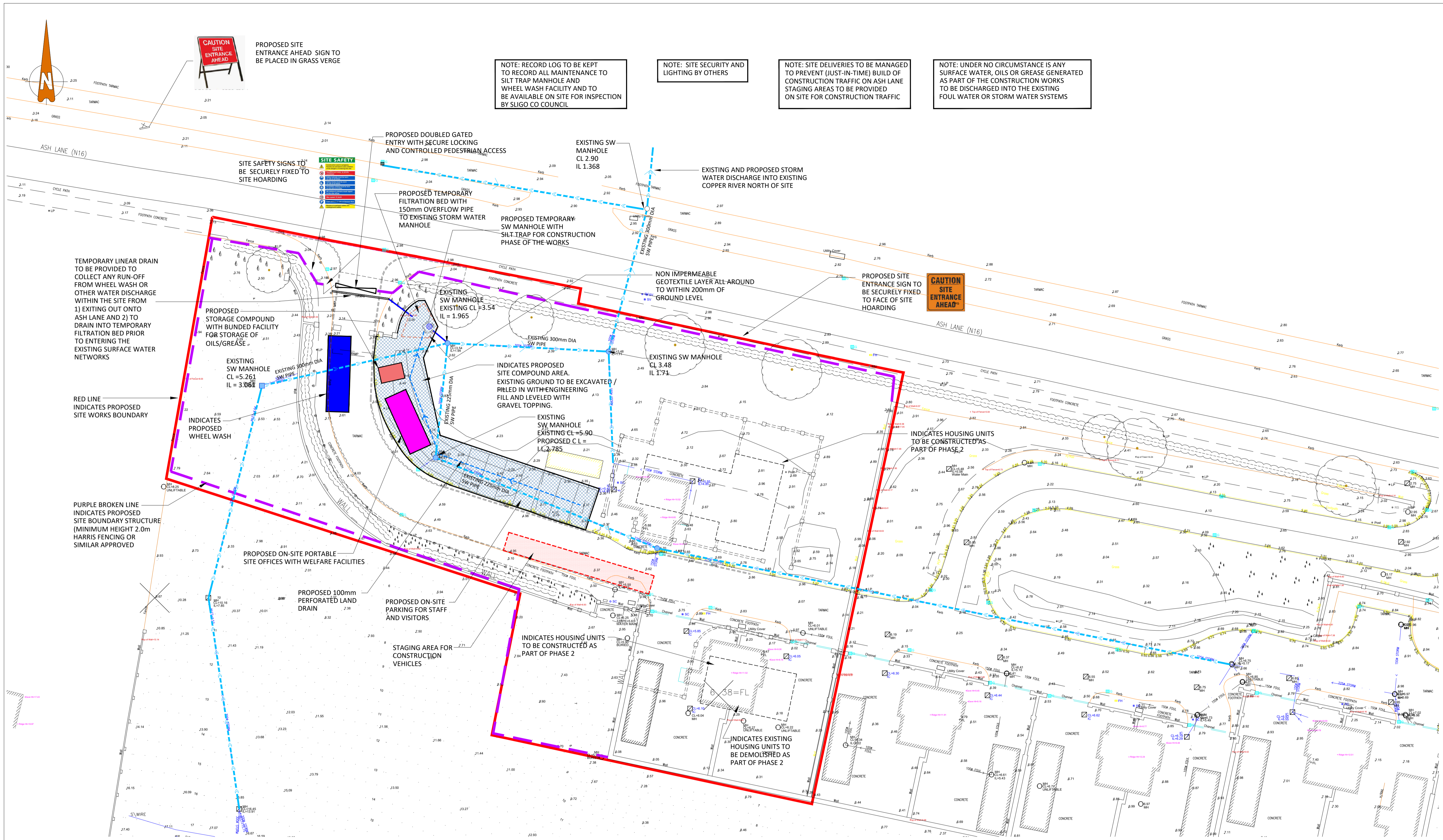

NOTE: RECORD LOG TO BE KEPT TO RECORD ALL MAINTENANCE TO SILT TRAP MANHOLE AND WHEEL WASH FACILITY AND TO BE AVAILABLE ON SITE FOR INSPECTION BY SLIGO CO COUNCIL

NOTE: SITE SECURITY AND LIGHTING BY OTHERS

NOTE: SITE DELIVERIES TO BE MANAGED TO PREVENT (JUST-IN-TIME) BUILD OF CONSTRUCTION TRAFFIC ON ASH LANE STAGING AREAS TO BE PROVIDED ON SITE FOR CONSTRUCTION TRAFFIC

NOTE: UNDER NO CIRCUMSTANCE IS ANY SURFACE WATER, OILS OR GREASE GENERATED AS PART OF THE CONSTRUCTION WORKS TO BE DISCHARGED INTO THE EXISTING FOUL WATER OR STORM WATER SYSTEMS

SITE COMPOUND LAYOUT
SCALE 1:250 @A1

TENDER DRAWING
NOT FOR CONSTRUCTION
THIS DRAWING HAS BEEN ISSUED FOR INFORMATION PURPOSES ONLY AND MUST NOT BE USED FOR CONSTRUCTION UNDER ANY CIRCUMSTANCES

- FOR SETTING OUT REFER TO ARCHITECT'S DRAWINGS.
- THIS DRAWING TO BE READ IN CONJUNCTION WITH ALL OTHER ARCHITECTURAL AND ENGINEERING DRAWINGS AND ALL OTHER RELEVANT DRAWINGS AND SPECIFICATIONS.
- DO NOT SCALE THIS DRAWING. USE FIGURED DIMENSIONS ONLY.
- NO PART OF THIS DOCUMENT MAY BE REPRODUCED OR TRANSMITTED IN ANY FORM OR STORED IN ANY RETRIEVAL SYSTEM OF ANY NATURE WITHOUT THE WRITTEN PERMISSION OF O'CONNOR SUTTON CRONIN AS COPYRIGHT HOLDER EXCEPT AS AGREED FOR USE ON THE PROJECT FOR WHICH THE DOCUMENT WAS ORIGINALLY ISSUED.

| Rev No. | Date | Revision Note | Drn by | Chkd by |
|---------|----------|-------------------|--------|---------|
| P01 | 27.06.23 | FOR INFORMATION | AD | TD |
| P02 | 16.08.23 | ISSUED FOR TENDER | AD | TD |

| Rev No. | Date | Revision Note | Drn by | Chkd by |
|---------|------|---------------|--------|---------|
| | | | | |
| | | | | |



2nd Floor, Technology House,
Galway Technology Park,
Parkmore,
Galway.

TEL +353 (0)91 771360
e: galway@ocsc.ie
w: www.ocsc.ie

Dublin | London | Belfast | Galway | Cork | Birmingham

Client: **SLIGO COUNTY COUNCIL**
Project: **ASH LANE GROUP HOUSING**

Title: **SITE COMPOUND AND CONSTRUCTION TRAFFIC**

Code | Originator | Zone | Level | Type | Role | Number | Status | Revision
S603 - OCSC - XX - XX - DR - C - 0606 | D2 | P02

Date: JUNE '23 Scale: 1:250 @ A1 Drn by: AD Chkd by: TD Aprvd by:



| LEGEND | |
|--------|---|
| | PROPOSED ROAD RESURFACING REFER TO DRAWING NO'S S603-OCSC-XX-XX-DR-C-0611 & 0612 |
| | PROPOSED NEW 100mm THICK CONCRETE FOOTWAY TO REFER TO DRAWING NO'S S603-OCSC-XX-XX-DR-C-0611 & 0612 & S603-OCSC-XX-XX-DR-S-0160 |
| | PROPOSED NEW 175mm THICK CONCRETE DRIVEWAY / VEHICULAR ACCESS REFER TO DRAWING NO'S S603-OCSC-XX-XX-DR-C-0611 & 0612 |
| | PROPOSED NEW 100mm THICK CONCRETE RAMP - GRADIENTS TO ARCHITECT DETAIL - REFER TO DRAWING NO'S S603-OCSC-XX-XX-DR-C-0611 & 0612 |
| | PROPOSED NEW 100mm THICK CONCRETE FOOTWAY TO PLACE EXISTING REFER TO DRAWING NO'S S603-OCSC-XX-XX-DR-C-0611 & 0612 |
| | PROPOSED NEW BRICK PAVING REFER TO DRAWING NO'S S603-OCSC-XX-XX-DR-C-0612 |
| | PROPOSED NEW PEDESTRIAN CROSSING REFER TO DRAWING NO S603-OCSC-XX-XX-DR-C-0611 |
| | PROPOSED LANDSCAPING BY ARCHITECT |
| | EXISTING ROAD CARRIAGEWAY |
| | EXISTING LANDSCAPING |
| | PROPOSED 125mm HIGH PRECAST CONCRETE KERBING |
| | PROPOSED DROPPED / DROPPER KERBING 0-6mm AT PEDESTRIAN CROSSING 25mm AT VEHICULAR ACCESS / SHARED SURFACE |
| | PROPOSED 150mm HIGH PRECAST CONCRETE KERBING |
| | PROPOSED BUFF COLOURED BLISTER TACTILE PAVING - REFER TO PLAN FOR EXTENT AND LAYOUTS. 400mm x 400mm x 50mm DEEP ON 25mm DEEP 3:1 CEMENT MORTAR BEDDING. REFER TO DRAWING NO S603-OCSC-XX-XX-DR-C-0611 FOR DETAILS |

NOTES:

REFER TO DRAWING NO: S603-OCSC-XX-XX-DR-C-0611 ROAD DETAILS SHEET 1 OF 2 (INCLUDING CROSS SECTIONS A-A, K-K, L-L & M-M)

REFER TO DRAWING NO: S603-OCSC-XX-XX-DR-C-0612 ROAD DETAILS SHEET 2 OF 2

REFER TO DRAWING NO: S603-OCSC-XX-XX-DR-S-0160 FOR DETAILS OF SECTIONS B-B, C-C & D-D

FOR DETAILS OF JOINTS IN CONCRETE SLABS REFER TO DRAWINGS NO S603-OCSC-XX-XX-DR-C-0614.

FOR DETAILS OF BOUNDARY WALLS DETAILS REFER TO DRAWINGS NO S603-OCSC-XX-XX-DR-S-0160 INCLUDING SECTIONS B-B, C-C, D-D, E-E, F-F, G-G, H-H, J-J

ROADS AND PAVEMENT LAYOUT
SCALE 1:250 @A1

- FOR SETTING OUT REFER TO ARCHITECT'S DRAWINGS.
- THIS DRAWING TO BE READ IN CONJUNCTION WITH ALL OTHER ARCHITECTURAL AND ENGINEERING DRAWINGS AND ALL OTHER RELEVANT DRAWINGS AND SPECIFICATIONS.
- DO NOT SCALE THIS DRAWING. USE FIGURED DIMENSIONS ONLY.
- NO PART OF THIS DOCUMENT MAY BE REPRODUCED OR TRANSMITTED IN ANY FORM OR STORED IN ANY RETRIEVAL SYSTEM OF ANY NATURE WITHOUT THE WRITTEN PERMISSION OF O'CONNOR SUTTON CROIN AS COPYRIGHT HOLDER EXCEPT AS AGREED FOR USE ON THE PROJECT FOR WHICH THE DOCUMENT WAS ORIGINALLY ISSUED.

| Rev No. | Date | Revision Note | Drn by | Chkd by |
|---------|----------|---|--------|---------|
| P01 | 02.02.23 | FOR INFORMATION | TD | TOD |
| P02 | 23.02.23 | PROPOSED WORKS UPDATED AS BUBBLED | TD | TOD |
| P03 | 02.03.23 | GENERAL REVISIONS | TD | TOD |
| P04 | 03.03.23 | SECTION MARK, D-D ADDED, WALL FOUNDATIONS ADDED | TD | TOD |
| P05 | 24.06.23 | REDLINE BOUNDARY UPDATED | AD | TD |
| P06 | 02.08.23 | LAYOUT UPDATED AS PER REVISED ARCHITECT LAYOUT | AD | TD |
| P07 | 16.08.23 | ISSUED FOR TENDER | AD | TD |

| Rev No. | Date | Revision Note | Drn by | Chkd by |
|---------|------|---------------|--------|---------|
| | | | | |
| | | | | |
| | | | | |
| | | | | |
| | | | | |



2nd Floor, Technology House,
Galway Technology Park,
Parkmore,
Galway.

TEL +353 (0)91 771360

e: galway@ocsc.ie
w: www.ocsc.ie

Dublin | London | Belfast | Galway | Cork | Birmingham

Client: SLIGO COUNTY COUNCIL
Project: ASH LANE GROUP HOUSING
Title: PROPOSED ROAD AND PAVEMENTS

Code | Originator | Zone | Level | Type | Role | Number | Status | Revision
S603-OCSC-XX-XX-DR-C-0610 | D2 | P07
Date: JAN '23 Scale: 1:250 @ A1 Drn by: AD Chkd by: TD Aprvd by:

TENDER DRAWING
NOT FOR CONSTRUCTION
THIS DRAWING HAS BEEN ISSUED FOR INFORMATION PURPOSES ONLY AND MUST NOT BE USED FOR CONSTRUCTION UNDER ANY CIRCUMSTANCES

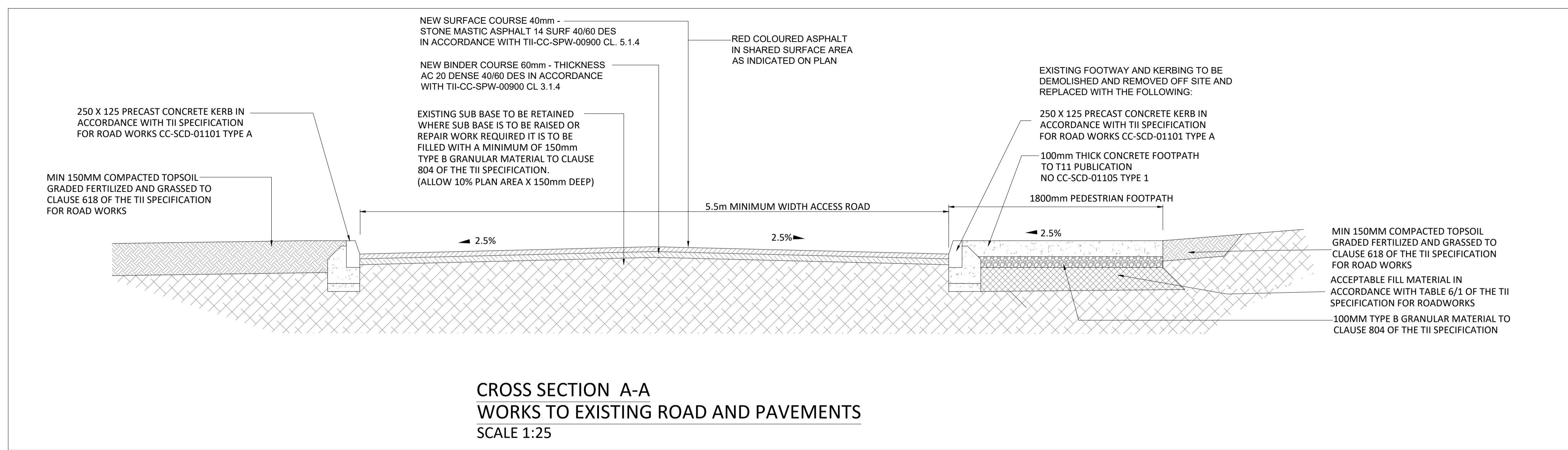

- NOTES:**
- DO NOT SCALE FROM THIS DRAWING USE STATED DIMENSIONS ONLY. IF IN DOUBT CONSULT THE ENGINEER.
 - ALL ROAD WORKS SHALL COMPLY WITH THE ENGINEERS SPECIFICATION AND THE TRANSPORT INFRASTRUCTURE IRELAND SPECIFICATION FOR ROAD WORKS.
 - TRAFFIC MANAGEMENT SHALL AT A MINIMUM COMPLY WITH TRAFFIC SIGNS MANUAL AND THE REQUIREMENTS OF THE RELEVANT LOCAL AUTHORITY, AND BE IN ACCORDANCE WITH THE CONTRACT.
 - THIS DRAWING SHALL BE READ IN CONJUNCTION WITH THE SPECIFICATION.
 - ALL EXCAVATIONS BELOW THE ROAD SHOULD BE BACK FILLED WITH CLASS 6F MATERIAL COMPACTED IN ACCORDANCE WITH TABLE 6.4 OF 600 SERIES OF THE SPECIFICATION FOR ROAD WORKS (TII).
 - GEOTEXTILE TO BE ADDED IF REQUIRED UPON INSPECTION BY ENGINEER.

NOTES:

REFER TO DRAWING NO: S603-OCSC-XX-XX-DR-C-0610 FOR ROAD AND PAVEMENT LAYOUT

REFER TO DRAWING NO: S603-OCSC-XX-XX-DR-C-0612 FOR ROAD AND PAVEMENT BUILD UP DETAILS

- NOTE (UNCONTROLLED CROSSING):**
- BLISTER TACTILE PAVING SLABS 400x400mm BUFF IN COLOUR;
 - THE TACTILE DOMES MUST BE LINED UP TO GIVE THE DIRECTION OF TRAVEL TO CROSS THE ROAD;
 - UTILITY/SERVICE BOXES SHOULD NOT BE LOCATED IN TACTILE PAVED AREAS WHERE POSSIBLE;
 - TACTILE SLABS SHALL BE CUT SO AS TO MINIMIZE THE CREATION OF SLIVERS ALONG THE KERB LINE;
 - ANY GULLIES IN THE CROSSING TO BE RELOCATED;
 - ALL DIMENSIONS ARE IN MILLIMETERS UNLESS OTHERWISE STANDARD.

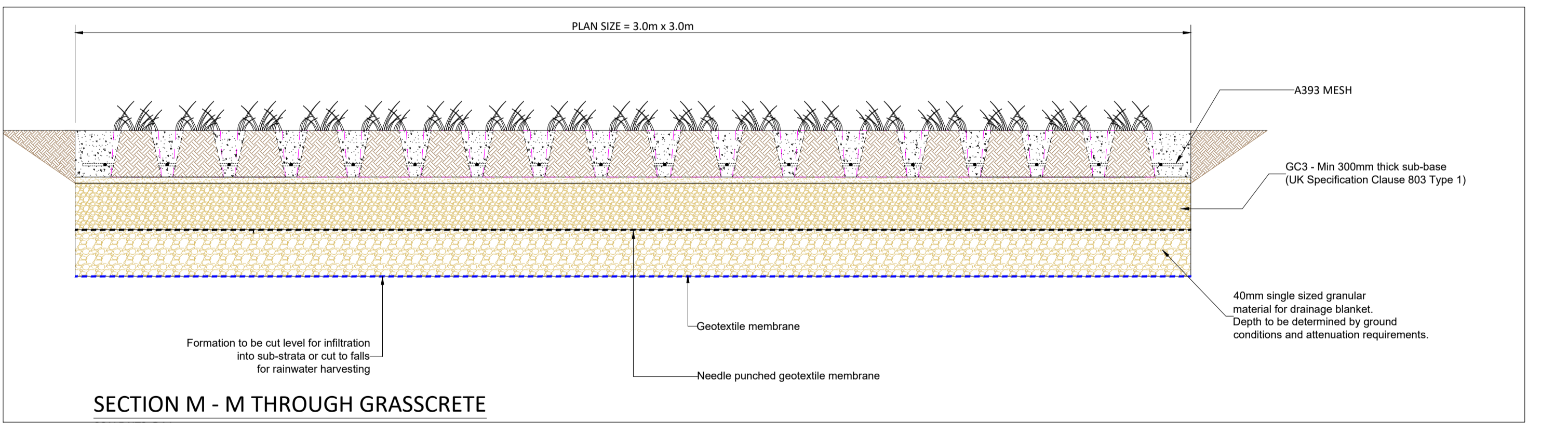
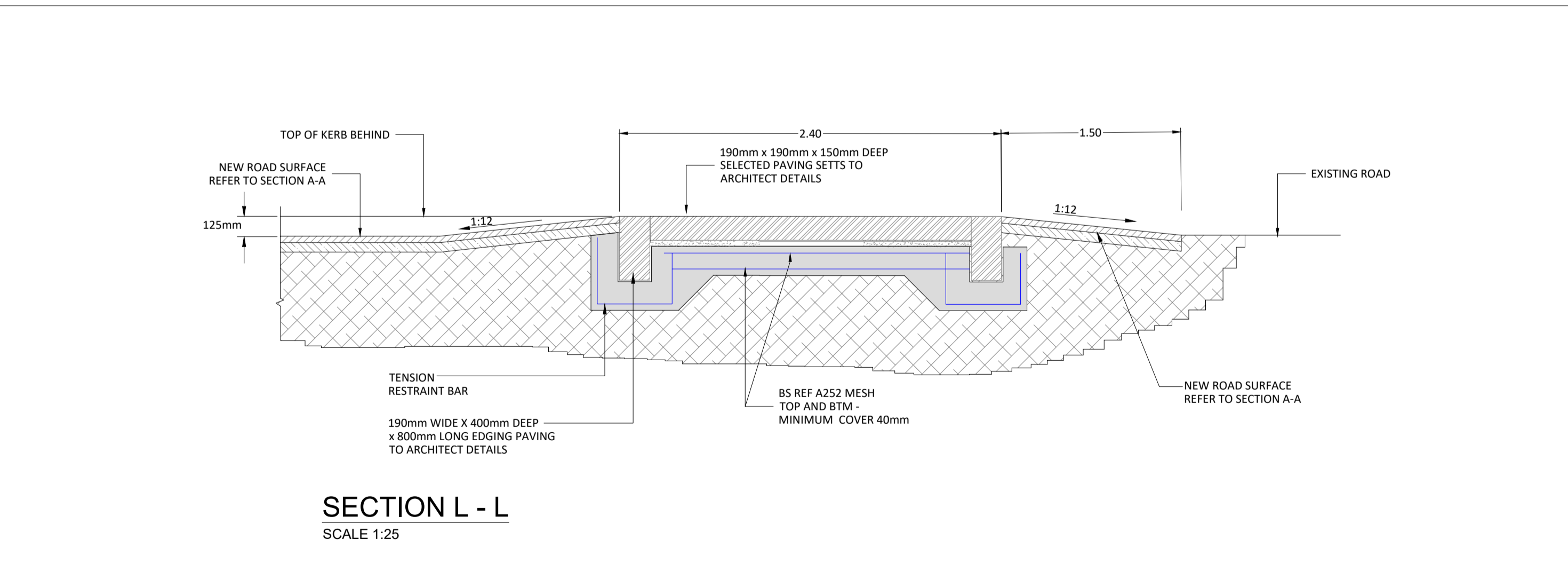
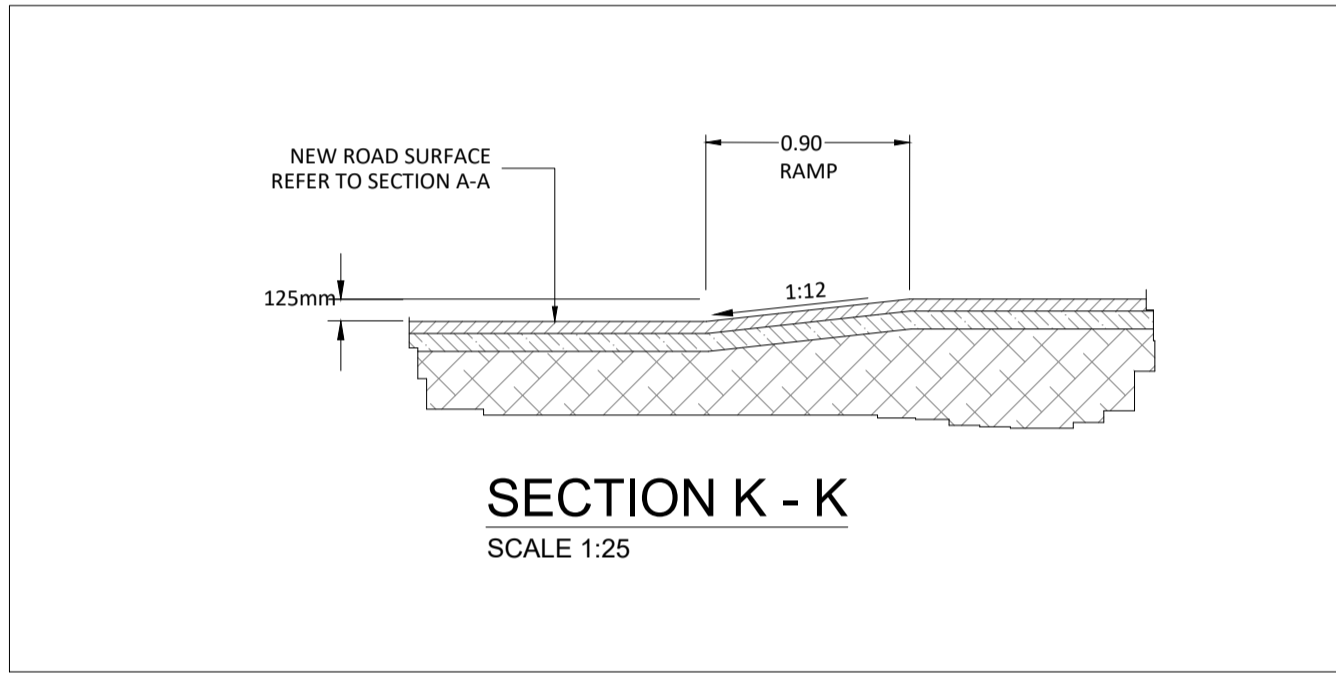
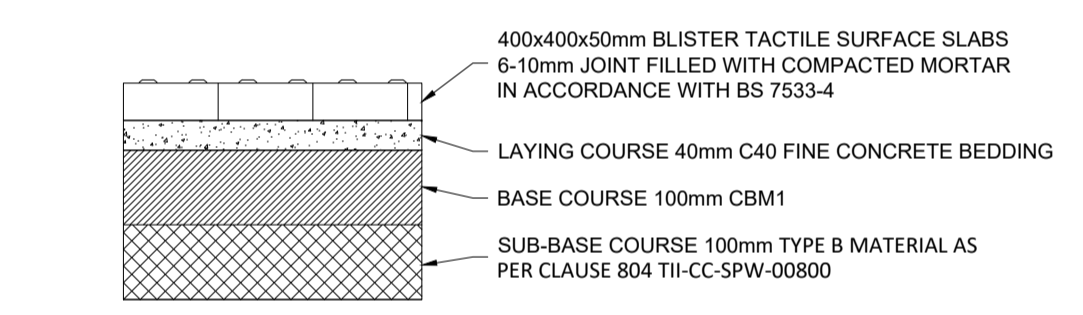
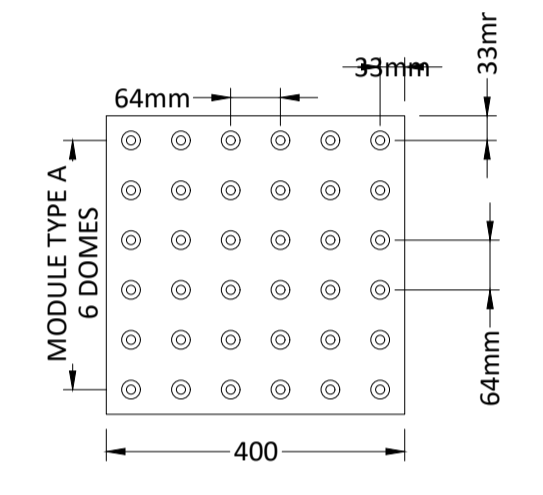
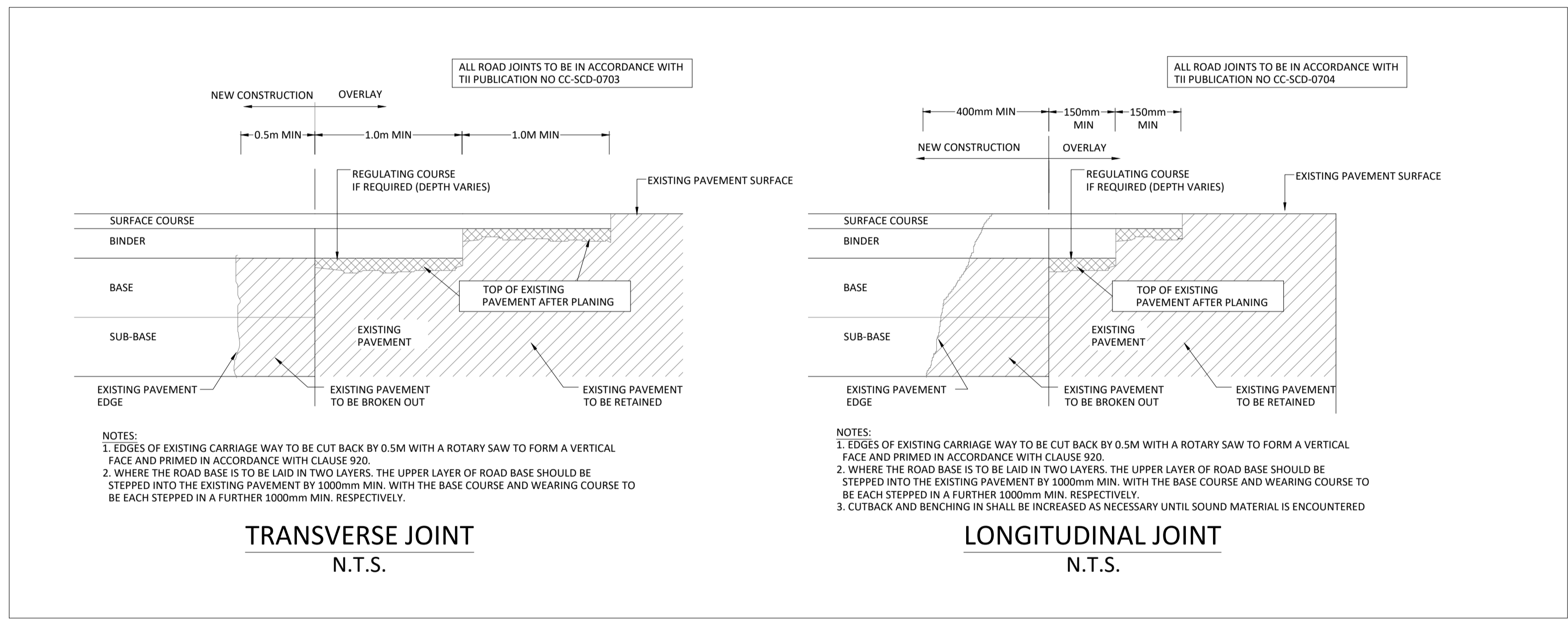

TENDER DRAWING NOT FOR CONSTRUCTION

THIS DRAWING HAS BEEN ISSUED FOR INFORMATION PURPOSES ONLY AND MUST NOT BE USED FOR CONSTRUCTION UNDER ANY CIRCUMSTANCES

- FOR SETTING OUT REFER TO ARCHITECT'S DRAWINGS.
- THIS DRAWING TO BE READ IN CONJUNCTION WITH ALL OTHER ARCHITECTURAL AND ENGINEERING DRAWINGS AND ALL OTHER RELEVANT DRAWINGS AND SPECIFICATIONS.
- DO NOT SCALE THIS DRAWING. USE FIGURED DIMENSIONS ONLY.
- NO PART OF THIS DOCUMENT MAY BE REPRODUCED OR TRANSMITTED IN ANY FORM OR STORED IN ANY RETRIEVAL SYSTEM OF ANY NATURE WITHOUT THE WRITTEN PERMISSION OF O'CONNOR SUTTON CRONIN AS COPYRIGHT HOLDER EXCEPT AS AGREED FOR USE ON THE PROJECT FOR WHICH THE DOCUMENT WAS ORIGINALLY ISSUED.

| Rev No. | Date | Revision Note | Drn by | Chkd by |
|---------|----------|-------------------|--------|---------|
| P01 | 23.02.23 | FOR INFORMATION | TD | TOD |
| P02 | 16.08.23 | ISSUED FOR TENDER | AD | TD |

| Rev No. | Date | Revision Note | Drn by | Chkd by |
|---------|------|---------------|--------|---------|
| | | | | |
| | | | | |



Second Floor
Technology House
Galway Technology Park
Parkmore
Galway

TEL +353 (0)91 771360

e: galway@ocsc.ie
w: www.ocsc.ie

Dublin | London | Belfast | Galway | Cork

Client: SLIGO COUNTY COUNCIL
Project: ASH LANE GROUP HOUSING
Title: ROAD DETAILS SHEET 1 OF 2

Code | Originator | Zone | Level | Type | Role | Number | Status | Revision
S603 - OCSC - XX - XX - DR - C - 0611 | D2 | P02
Date: FEB '23 Scale: A.N. @ A1 Drn by: TD Chkd by: TOD Aprvd by:

**RESURFACING EXISTING
INTERNAL ROAD**

**RED COLOURED AS
INDICATED ON PLAN

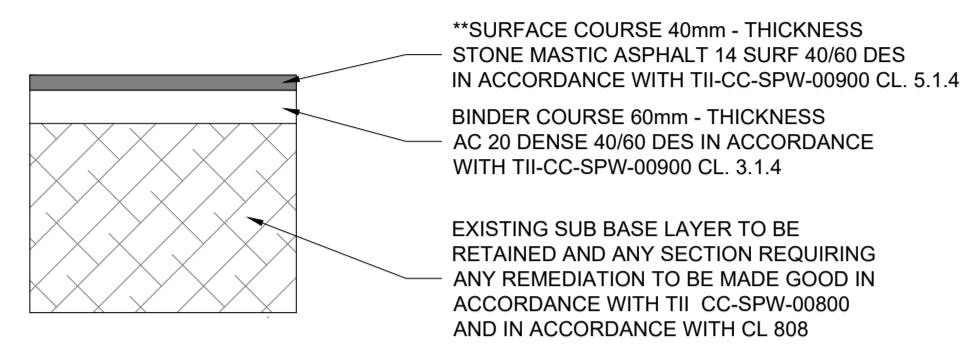

**SURFACE COURSE 40mm - THICKNESS
STONE MASTIC ASPHALT 14 SURF 40/60 DES
IN ACCORDANCE WITH TII-CC-SPW-00900 CL. 5.1.4

BINDER COURSE 60mm - THICKNESS
AC 20 DENSE 40/60 DES IN ACCORDANCE
WITH TII-CC-SPW-00900 CL. 3.1.4

EXISTING SUB BASE LAYER TO BE
RETAINED AND ANY SECTION REQUIRING
ANY REMEDIATION TO BE MADE GOOD IN
ACCORDANCE WITH TII CC-SPW-00800
AND IN ACCORDANCE WITH CL 808

**PROPOSED NEW
INTERNAL ROAD BUILD-UP**

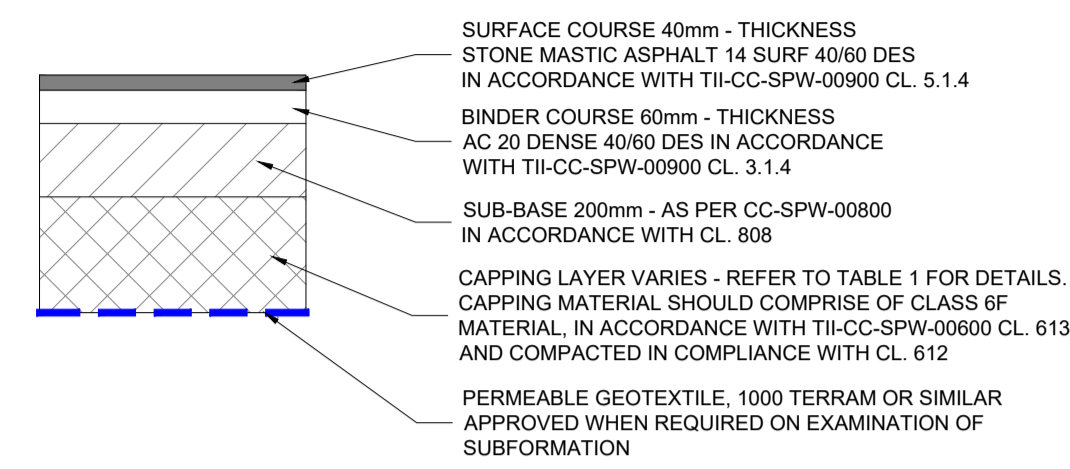

SURFACE COURSE 40mm - THICKNESS
STONE MASTIC ASPHALT 14 SURF 40/60 DES
IN ACCORDANCE WITH TII-CC-SPW-00900 CL. 5.1.4

BINDER COURSE 60mm - THICKNESS
AC 20 DENSE 40/60 DES IN ACCORDANCE
WITH TII-CC-SPW-00900 CL. 3.1.4

SUB-BASE 200mm - AS PER CC-SPW-00800
IN ACCORDANCE WITH CL. 808

CAPPING LAYER VARIES - REFER TO TABLE 1 FOR DETAILS.
CAPPING MATERIAL SHOULD COMPRISE OF CLASS 6F
MATERIAL. IN ACCORDANCE WITH TII-CC-SPW-00600 CL. 613
AND COMPACTED IN COMPLIANCE WITH CL. 612

PERMEABLE GEOTEXTILE. 1000 TERRAM OR SIMILAR
APPROVED WHEN REQUIRED ON EXAMINATION OF
SUBFORMATION

**PAVING SETTS TO ARCHITECT
TRAFFICABLE - INTERNAL ROAD**

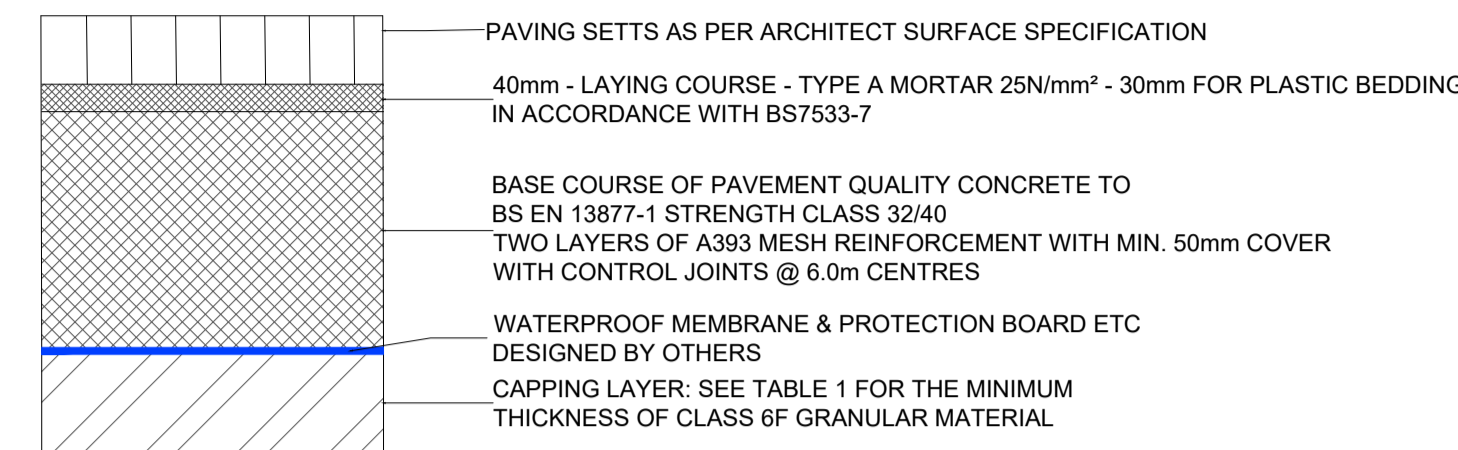

PAVING SETTS AS PER ARCHITECT SURFACE SPECIFICATION

40mm - LAYING COURSE - TYPE A MORTAR 25N/mm² - 30mm FOR PLASTIC BEDDING
IN ACCORDANCE WITH BS7533-7

BASE COURSE OF PAVEMENT QUALITY CONCRETE TO
BS EN 13877-1 STRENGTH CLASS 32/40
TWO LAYERS OF A393 MESH REINFORCEMENT WITH MIN. 50mm COVER
WITH CONTROL JOINTS @ 6.0m CENTRES

WATERPROOF MEMBRANE & PROTECTION BOARD ETC
DESIGNED BY OTHERS

CAPPING LAYER: SEE TABLE 1 FOR THE MINIMUM
THICKNESS OF CLASS 6F GRANULAR MATERIAL

NOTES:

- DO NOT SCALE FROM THIS DRAWING USE STATED DIMENSIONS ONLY. IF IN DOUBT CONSULT THE ENGINEER.
- ALL ROAD WORKS SHALL COMPLY WITH THE ENGINEERS SPECIFICATION AND THE TRANSPORT INFRASTRUCTURE IRELAND SPECIFICATION FOR ROAD WORKS.
- TRAFFIC MANAGEMENT SHALL AT A MINIMUM COMPLY WITH TRAFFIC SIGNS MANUAL AND THE REQUIREMENTS OF THE RELEVANT LOCAL AUTHORITY, AND BE IN ACCORDANCE WITH THE CONTRACT.
- THIS DRAWING SHALL BE READ IN CONJUNCTION WITH THE SPECIFICATION.
- ALL EXCAVATIONS BELOW THE ROAD SHOULD BE BACK FILLED WITH CLASS 6F MATERIAL COMPACTED IN ACCORDANCE WITH TABLE 6.4 OF 600 SERIES OF THE SPECIFICATION FOR ROAD WORKS (TII).
- GEOTEXTILE TO BE ADDED IF REQUIRED UPON INSPECTION BY ENGINEER.

NOTES:

REFER TO DRAWING NO: S603-OCSC-XX-XX-DR-C-0610
FOR ROAD AND PAVEMENT LAYOUT

REFER TO DRAWING NO: S603-OCSC-XX-XX-DR-C-0611
FOR ROAD CROSS SECTIONS

**PAVIOURS - VARIOUS SIZES - ON
SUBGRADE - NON TRAFFICABLE**

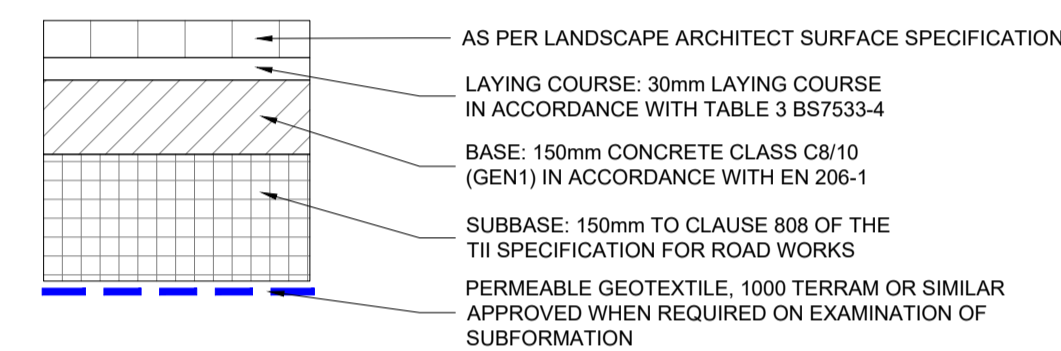

AS PER LANDSCAPE ARCHITECT SURFACE SPECIFICATION

LAYING COURSE: 30mm LAYING COURSE
IN ACCORDANCE WITH TABLE 3 BS7533-4

BASE: 150mm CONCRETE CLASS C8/10
(GEN1) IN ACCORDANCE WITH EN 206-1

SUBBASE: 150mm TO CLAUSE 808 OF THE
TII SPECIFICATION FOR ROAD WORKS

PERMEABLE GEOTEXTILE. 1000 TERRAM OR SIMILAR
APPROVED WHEN REQUIRED ON EXAMINATION OF
SUBFORMATION

**DETAIL F
IN-SITU CONCRETE FOOTWAY + NON VEHICULAR CONCRETE PAVEMENTS
PEDESTRIAN USE ONLY**

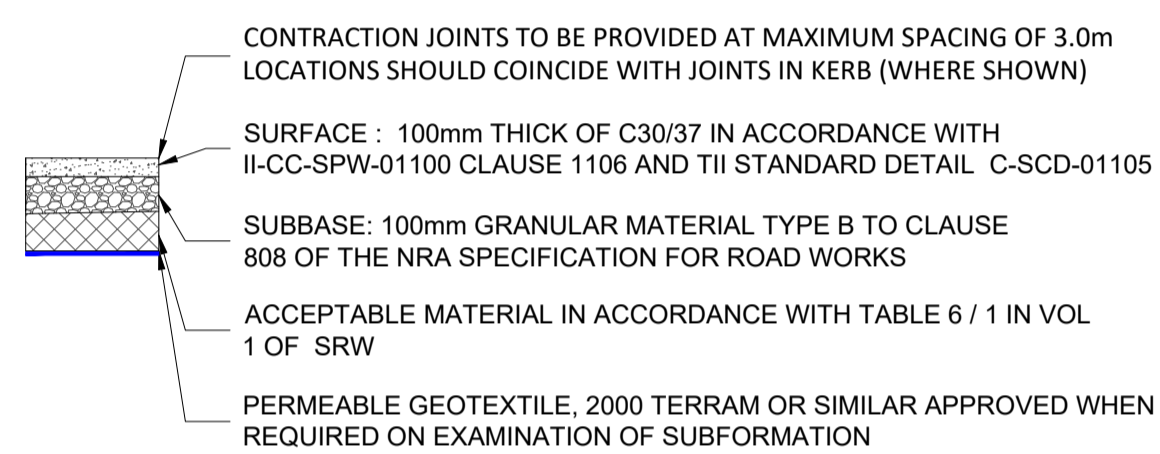

CONTRACTION JOINTS TO BE PROVIDED AT MAXIMUM SPACING OF 3.0m
LOCATIONS SHOULD COINCIDE WITH JOINTS IN KERB (WHERE SHOWN)

SURFACE : 100mm THICK OF C30/37 IN ACCORDANCE WITH
II-CC-SPW-01100 CLAUSE 1106 AND TII STANDARD DETAIL C-SCD-01105

SUBBASE: 100mm GRANULAR MATERIAL TYPE B TO CLAUSE
808 OF THE NRA SPECIFICATION FOR ROAD WORKS

ACCEPTABLE MATERIAL IN ACCORDANCE WITH TABLE 6 / 1 IN VOL
1 OF SRW

PERMEABLE GEOTEXTILE. 2000 TERRAM OR SIMILAR APPROVED WHEN
REQUIRED ON EXAMINATION OF SUBFORMATION

**DETAIL E
IN-SITU CONCRETE IN DRIVEWAYS
VEHICULAR USE**

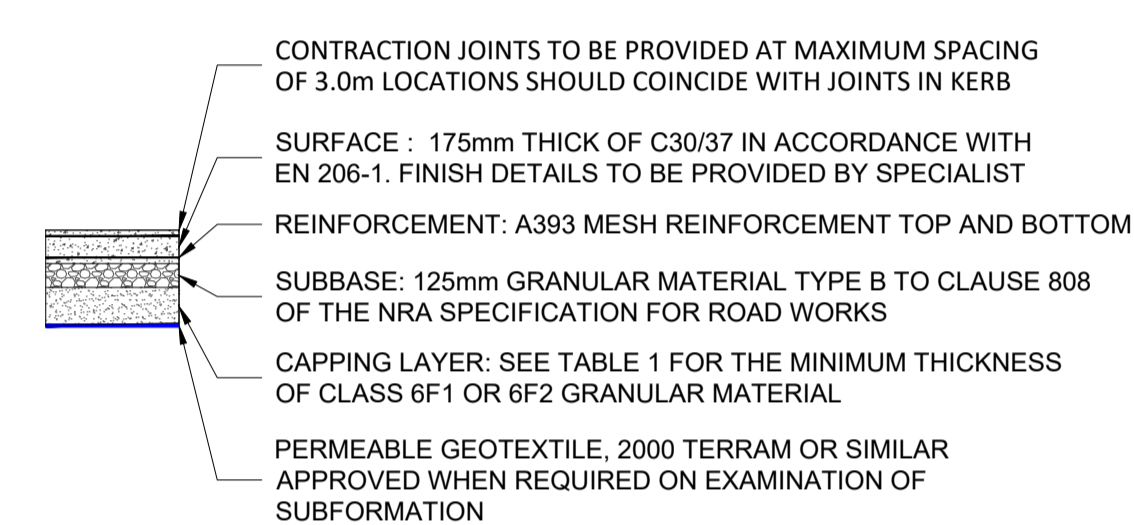

CONTRACTION JOINTS TO BE PROVIDED AT MAXIMUM SPACING OF
3.0m LOCATIONS SHOULD COINCIDE WITH JOINTS IN KERB

SURFACE : 175mm THICK OF C30/37 IN ACCORDANCE WITH
EN 206-1. FINISH DETAILS TO BE PROVIDED BY SPECIALIST

REINFORCEMENT: A393 MESH REINFORCEMENT TOP AND BOTTOM

SUBBASE: 125mm GRANULAR MATERIAL TYPE B TO CLAUSE 808
OF THE NRA SPECIFICATION FOR ROAD WORKS

CAPPING LAYER: SEE TABLE 1 FOR THE MINIMUM THICKNESS
OF CLASS 6F1 OR 6F2 GRANULAR MATERIAL

PERMEABLE GEOTEXTILE. 2000 TERRAM OR SIMILAR
APPROVED WHEN REQUIRED ON EXAMINATION OF
SUBFORMATION

**RAISED TABLE
BUILD-UP**

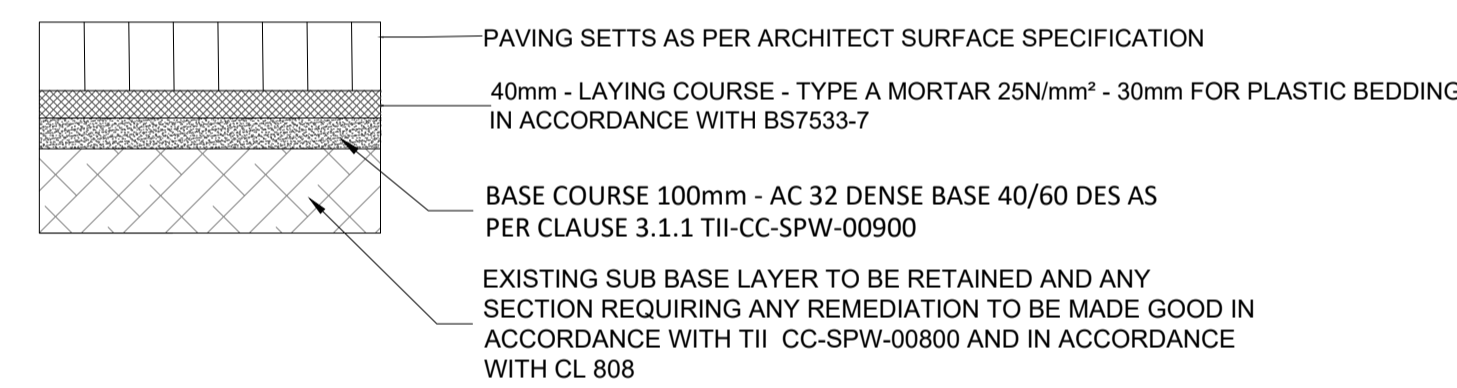

PAVING SETTS AS PER ARCHITECT SURFACE SPECIFICATION

40mm - LAYING COURSE - TYPE A MORTAR 25N/mm² - 30mm FOR PLASTIC BEDDING
IN ACCORDANCE WITH BS7533-7

BASE COURSE 100mm - AC 32 DENSE BASE 40/60 DES AS
PER CLAUSE 3.1.1 TII-CC-SPW-00900

EXISTING SUB BASE LAYER TO BE RETAINED AND ANY
SECTION REQUIRING ANY REMEDIATION TO BE MADE GOOD IN
ACCORDANCE WITH TII CC-SPW-00800 AND IN ACCORDANCE
WITH CL 808

TABLE 1: CAPPING LAYER DEPTH

THE MINIMUM REQUIRED THICKNESS OF NON-FROST
SUSCEPTIBLE CAPPING MATERIAL IS SHOWN HEREUNDER:

| CBR SUBGRADE (%) | <2.5 | 2.5 | 3 | 4 | 5-15 | >15 |
|---------------------------------|---|-----|-----|-----|------|-----|
| THICKNESS OF CAPPING LAYER (mm) | SPECIALIST GEOTECHNICAL ADVISE REQUIRED | 600 | 350 | 300 | 250 | 150 |

CBR TESTS SHALL BE CARRIED OUT AT A RATE OF
ONE TEST PER 100 METERS OF ROAD
OR WHERE THE SOIL TYPE CHANGES

**TENDER DRAWING
NOT FOR CONSTRUCTION**

THIS DRAWING HAS BEEN ISSUED FOR INFORMATION
PURPOSES ONLY AND MUST NOT BE USED
FOR CONSTRUCTION UNDER ANY CIRCUMSTANCES

- FOR SETTING OUT REFER TO ARCHITECT'S DRAWINGS.
- THIS DRAWING TO BE READ IN CONJUNCTION WITH ALL OTHER ARCHITECTURAL AND ENGINEERING DRAWINGS AND ALL OTHER RELEVANT DRAWINGS AND SPECIFICATIONS.
- DO NOT SCALE THIS DRAWING. USE FIGURED DIMENSIONS ONLY.
- NO PART OF THIS DOCUMENT MAY BE REPRODUCED OR TRANSMITTED IN ANY FORM OR STORED IN ANY RETRIEVAL SYSTEM OF ANY NATURE WITHOUT THE WRITTEN PERMISSION OF O'CONNOR SUTTON CROMIN AS COPYRIGHT HOLDER EXCEPT AS AGREED FOR USE ON THE PROJECT FOR WHICH THE DOCUMENT WAS ORIGINALLY ISSUED.

| Rev No. | Date | Revision Note | Drn by | Chkd by | Rev No. | Date | Revision Note | Drn by | Chkd by |
|---------|----------|-------------------|--------|---------|---------|------|---------------|--------|---------|
| P01 | 23.02.23 | FOR INFORMATION | TD | TOD | | | | | |
| P02 | 16.08.23 | ISSUED FOR TENDER | AD | TD | | | | | |



Second Floor
Technology House
Galway Technology Park
Parkmore
Galway

TEL +353 (0)91 771360

e: galway@ocsc.ie
w: www.ocsc.ie

Dublin | London | Belfast | Galway | Cork



Client: SLIGO COUNTY COUNCIL
Project: ASH LANE GROUP HOUSING

Title: ROAD DETAILS SHEET 2 OF 2

Code | Originator | Zone | Level | Type | Role | Number | Status | Revision
S603 - OCSC - XX - XX - DR - C - 0612 | D2 | P02

Date: FEB '23 Scale: A.N. @ A1 Drn by: AD Chkd by: TD Aprvd by:



| LEGEND | |
|--------|------------------------------|
| | BROKEN CENTRE LINE RRM 002B |
| | CONTINUOUS LINE RRM 001 |
| | ROAD STOP SIGN |
| | STOP ROAD STOP MARKING M 114 |
| | ROAD STOP LINE RRM 017 |

ROAD MARKINGS AND SIGNAGE LAYOUT
SCALE 1:250 @A1

- FOR SETTING OUT REFER TO ARCHITECT'S DRAWINGS.
- THIS DRAWING TO BE READ IN CONJUNCTION WITH ALL OTHER ARCHITECTURAL AND ENGINEERING DRAWINGS AND ALL OTHER RELEVANT DRAWINGS AND SPECIFICATIONS.
- DO NOT SCALE THIS DRAWING. USE FIGURED DIMENSIONS ONLY.
- NO PART OF THIS DOCUMENT MAY BE REPRODUCED OR TRANSMITTED IN ANY FORM OR STORED IN ANY RETRIEVAL SYSTEM OF ANY NATURE WITHOUT THE WRITTEN PERMISSION OF O'CONNOR SUTTON CRONIN AS COPYRIGHT HOLDER EXCEPT AS AGREED FOR USE ON THE PROJECT FOR WHICH THE DOCUMENT WAS ORIGINALLY ISSUED.

| Rev No. | Date | Revision Note | Drn by | Chkd by |
|---------|----------|-------------------|--------|---------|
| P01 | 16.08.23 | ISSUED FOR TENDER | AD | TD |
| | | | | |
| | | | | |
| | | | | |

| Rev No. | Date | Revision Note | Drn by | Chkd by |
|---------|------|---------------|--------|---------|
| | | | | |
| | | | | |
| | | | | |
| | | | | |

2nd Floor, Technology House,
Galway Technology Park,
Parkmore,
Galway.

TEL +353 (0)91 771360

e: galway@ocsc.ie
w: www.ocsc.ie

Dublin | London | Belfast | Galway | Cork | Birmingham

| | | | | | | | | | | | |
|----------|---------------------------|--------|-------|------|------|---------|--------|----------|----|-----------|--|
| Client: | SLIGO COUNTY COUNCIL | | | | | | | | | | |
| Project: | ASH LANE GROUP HOUSING | | | | | | | | | | |
| Title: | ROAD MARKINGS AND SIGNAGE | | | | | | | | | | |
| Code | Originator | Zone | Level | Type | Role | Number | Status | Revision | | | |
| S603 | OCSC | XX | XX | DR | C | 0613 | D2 | P01 | | | |
| Date: | AUG '23 | Scale: | 1:250 | @ | A1 | Drn by: | AD | Chkd by: | TD | Aprvd by: | |

TENDER DRAWING
NOT FOR CONSTRUCTION
THIS DRAWING HAS BEEN ISSUED FOR INFORMATION PURPOSES ONLY AND MUST NOT BE USED FOR CONSTRUCTION UNDER ANY CIRCUMSTANCES

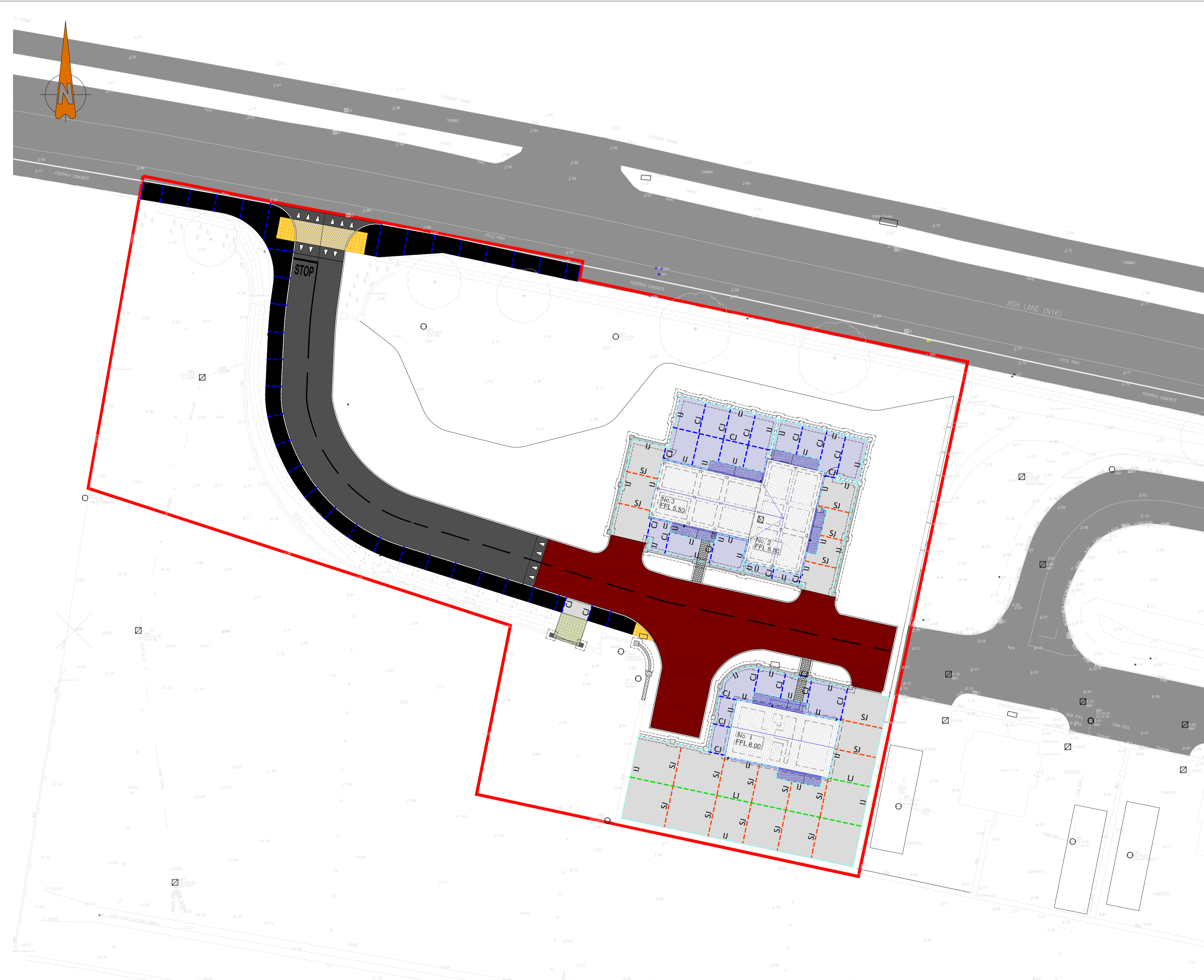

| LEGEND | |
|--------|--|
| | LONGITUDINAL CONSTRUCTION JOINT. REFER TO TYPE 1 RCD/100/7 |
| | SAW JOINT @ 4.5m CRS MAXIMUM. REFER TO RCD/1000/4 |
| | JOINT FORMER & SAW CUT @ 3.0m CRS MAXIMUM IN 100mm FOOTPATH / CONCRETE PAVEMENTS |
| | 10mm ISOLATION JOINT. |

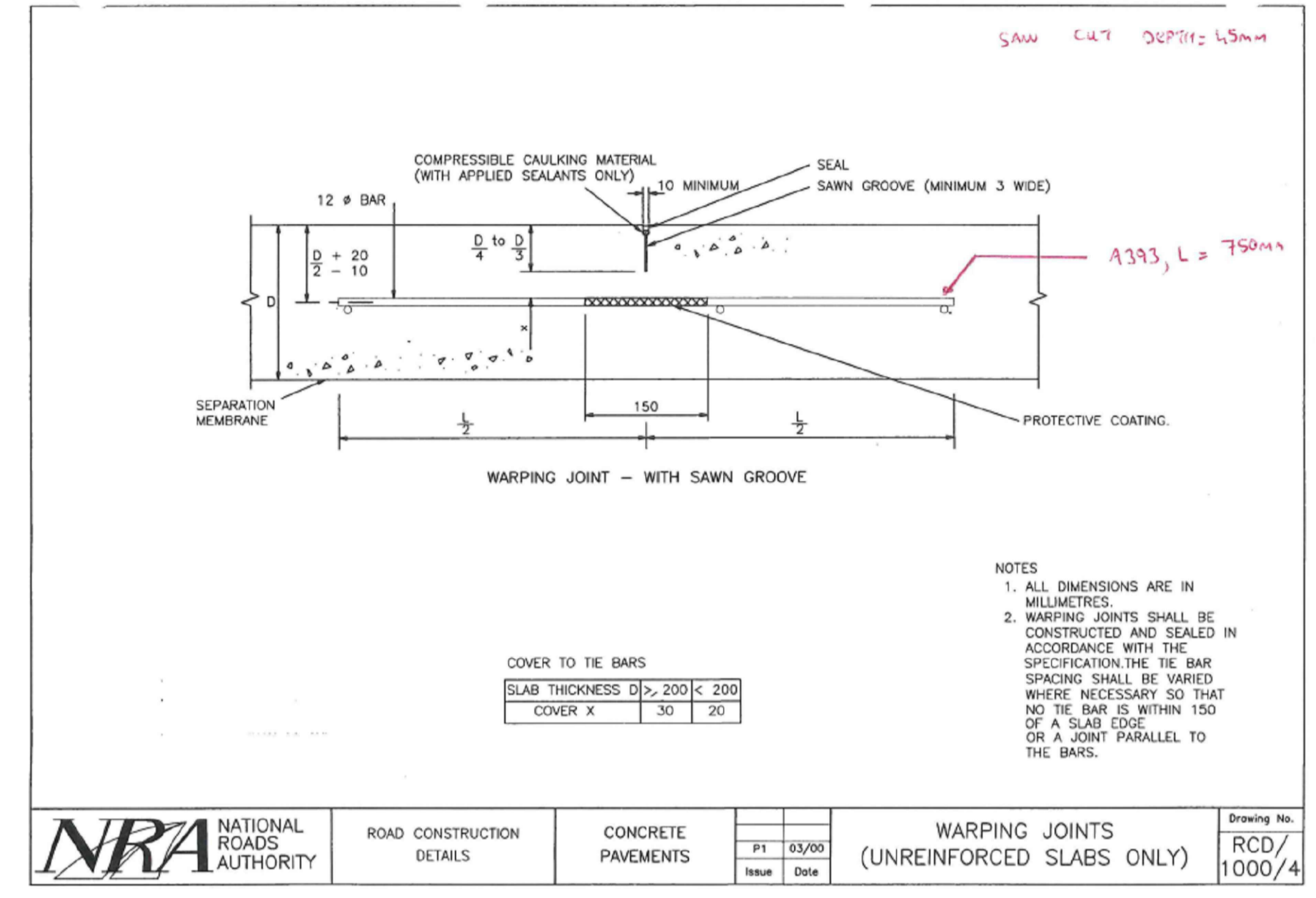

| | | | | | | | | |
|-------------------------------------|---------------------------|--------------------|----|-------|-------|------|--|------------------------|
| NRA NATIONAL ROADS AUTHORITY | ROAD CONSTRUCTION DETAILS | CONCRETE PAVEMENTS | P1 | 03/00 | Issue | Date | WARPING JOINTS (UNREINFORCED SLABS ONLY) | Drawing No. RCD/1000/4 |
| | | | | | | | | |

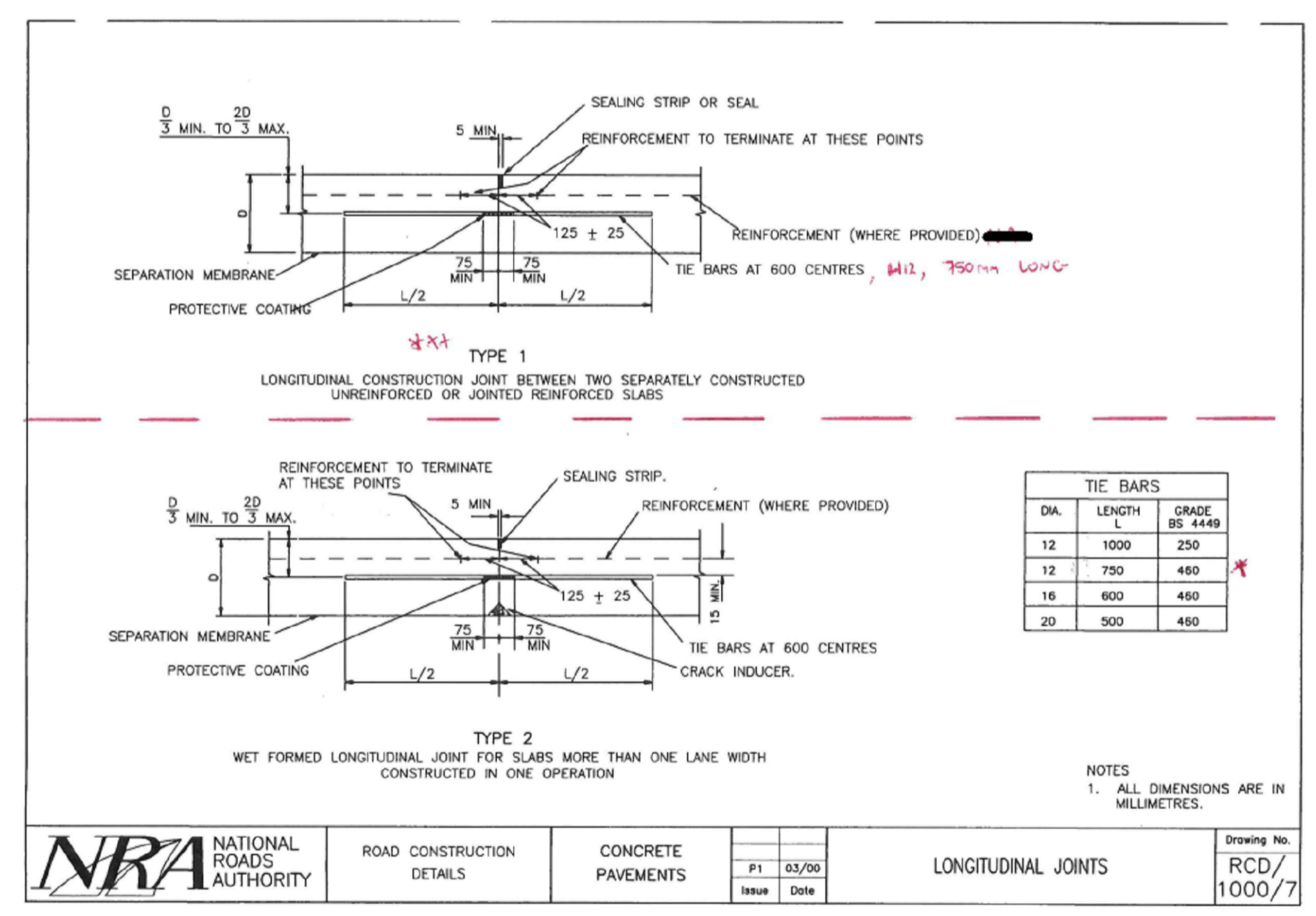

| | | | | | | | | |
|-------------------------------------|---------------------------|--------------------|----|-------|-------|------|---------------------|------------------------|
| NRA NATIONAL ROADS AUTHORITY | ROAD CONSTRUCTION DETAILS | CONCRETE PAVEMENTS | P1 | 03/00 | Issue | Date | LONGITUDINAL JOINTS | Drawing No. RCD/1000/7 |
| | | | | | | | | |

CONCRETE PAVEMENT JOINTS - LAYOUT PLAN
SCALE 1:250 @A1

TENDER DRAWING
NOT FOR CONSTRUCTION
THIS DRAWING HAS BEEN ISSUED FOR INFORMATION PURPOSES ONLY AND MUST NOT BE USED FOR CONSTRUCTION UNDER ANY CIRCUMSTANCES

- FOR SETTING OUT REFER TO ARCHITECT'S DRAWINGS.
- THIS DRAWING TO BE READ IN CONJUNCTION WITH ALL OTHER ARCHITECTURAL AND ENGINEERING DRAWINGS AND ALL OTHER RELEVANT DRAWINGS AND SPECIFICATIONS.
- DO NOT SCALE THIS DRAWING. USE FIGURED DIMENSIONS ONLY.
- NO PART OF THIS DOCUMENT MAY BE REPRODUCED OR TRANSMITTED IN ANY FORM OR STORED IN ANY RETRIEVAL SYSTEM OF ANY NATURE WITHOUT THE WRITTEN PERMISSION OF O'CONNOR SUTTON CRONIN AS COPYRIGHT HOLDER EXCEPT AS AGREED FOR USE ON THE PROJECT FOR WHICH THE DOCUMENT WAS ORIGINALLY ISSUED.

| Rev No. | Date | Revision Note | Drn by | Chkd by |
|---------|----------|-------------------|--------|---------|
| P01 | 16.08.23 | ISSUED FOR TENDER | AD | TD |

| Rev No. | Date | Revision Note | Drn by | Chkd by |
|---------|------|---------------|--------|---------|
| | | | | |



2nd Floor, Technology House,
Galway Technology Park,
Parkmore,
Galway.

TEL +353 (0)91 771360

e: galway@ocsc.ie
w: www.ocsc.ie

Dublin | London | Belfast | Galway | Cork | Birmingham



Client: **SLIGO COUNTY COUNCIL**
Project: **ASH LANE GROUP HOUSING**

Title: **CONCRETE PAVEMENTS JOINTS LAYOUT PLAN**

| | | | | | | | | |
|------|------------|------|-------|------|------|--------|--------|----------|
| Code | Originator | Zone | Level | Type | Role | Number | Status | Revision |
| S603 | OCSC | XX | XX | DR | C | 0614 | D2 | P01 |

Date: JAN '23 Scale: 1:250 @ A1 Drn by: AD Chkd by: TD Aprvd by:

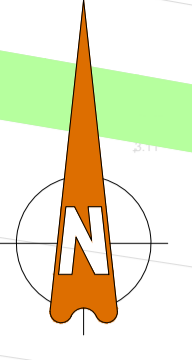

ALL MANHOLE AND ACCESS CHAMBER / AJ's COVERS TO BE CLASS D400 IN TRAFFICKED AREAS. B125 ELSEWHERE. ALL TO BE DOUBLE SEALED AN EXISTING AND PROPOSED MANHOLES IN ACCESS ROAD AND ADJACENT TO THE ATTENUATION TANK TO BE LOCKABLE TYPE TO SCC SPECIFICATION

ALL PIPE WORK WITH LESS THAN 1200mm COVER TO BE ENCASED IN 100mm CONCRETE SURROUND

STORM WATER PIPES ADJACENT TO THE PROPOSED BUILDINGS TO BE GRADE SN8

STORM WATER PIPES IN THE ACCESS ROAD TO BE CORRUGATED TWINWALL

LEGEND

| STORM DRAINAGE NETWORK | |
|------------------------|--|
| | EXISTING STORM DRAINAGE PIPES TO BE RETAINED |
| | EXISTING STORM DRAINAGE PIPES TO BE DEMOLISHED |
| | EXISTING STORM DRAINAGE MANHOLES TO BE RETAINED |
| | PROPOSED STORM WATER MANHOLES |
| | PROPOSED STORM DRAINAGE AJ's AC's |
| | PROPOSED TWINWALL STORM DRAINAGE PIPES GRADE SN8 |
| | PROPOSED ACO DRAINS |
| | YARD GULLY TO SPECIALIST DETAIL |

STORM WATER NETWORK - PIPELINE DETAILS

| USMH | USCL (m) | USIL (m) | USMH Dia (mm) | PN | Dia (mm) | Length (m) | Slope (1:X) | DSMH | DSIL (m) |
|------|----------|----------|---------------|-------|----------|------------|-------------|------|----------|
| S1 | 6.050 | 4.700 | 1200 | 1.000 | 225 | 40.000 | 40.0 | S2 | 3.700 |
| S2 | 4.830 | 3.700 | 1200 | 1.001 | 225 | 19.950 | 35.0 | S3 | 3.130 |
| S3 | 4.050 | 3.130 | 1200 | 1.002 | 225 | 11.890 | 34.0 | S4 | 2.780 |
| S4 | 3.510 | 2.780 | 1200 | 1.003 | 225 | 7.240 | 55.0 | S5 | 2.649 |
| S5 | 3.700 | 2.649 | 1200 | 1.004 | 225 | 8.200 | 50.0 | S6 | 2.485 |

- ### NOTES
- ALL NOTED LEVELS ARE TO ORDNANCE DATUM, MALIN HEAD.
 - REFER TO ARCHITECT'S LAYOUT FOR ALL SET-OUT INFORMATION.
 - REFER TO ARCHITECT / LANDSCAPE ARCHITECT'S DESIGN DRAWINGS FOR DETAILS OF PROPOSED SURFACE FINISHES AND LANDSCAPING.
 - ALL SURFACE WATER DRAINAGE IS TO BE INSTALLED IN ACCORDANCE WITH THE GREATER DUBLIN REGION CODE OF PRACTICE FOR DRAINAGE WORKS, THE BUILDING REGULATIONS PART H AND THE SITE DEVELOPMENT SPECIFICATION.
 - ALL WASTEWATER DRAINAGE IS TO BE INSTALLED IN ACCORDANCE WITH THE IRISH WATER CODE OF PRACTICE FOR WASTEWATER INFRASTRUCTURE, THE BUILDING REGULATIONS PART H AND THE SITE DEVELOPMENT SPECIFICATION.
 - ALL DRAINAGE COVER LEVELS ARE TO BE COORDINATED WITH THE PROPOSED ROAD DESIGN LEVELS AND ARCHITECT DESIGN FINISH DETAILS.
 - ALL CONNECTIONS TO NEW DRAINAGE NETWORKS ARE TO BE MADE AT AN ANGLE OF 90° OR IN THE DIRECTION OF FLOW.
 - THE CONTRACTOR IS TO VERIFY INVERT LEVEL AT PROPOSED CONNECTION TO EXISTING SEWERS, PRIOR TO ANY OTHER WORKS BEING CARRIED OUT, AND MAKE ANY DISCREPANCIES KNOWN TO THE ENGINEER.
 - THE CONTRACTOR IS RESPONSIBLE FOR CONFIRMATION OF PRESENCE ALL EXISTING UTILITIES, IF ANY, ALONG ROUTE OF PROPOSED DRAINAGE NETWORKS - BY INTRUSIVE INVESTIGATION OR EQUAL.
 - EXISTING PUBLIC SEWER TO BE JET CLEANED AND CCTV SURVEYED PRIOR TO, AND AFTER PROPOSED CONNECTIONS FROM NEW NETWORK.
 - ALL NEW DRAINAGE INFRASTRUCTURE TO BE JET CLEANED AND CCTV SURVEYED, WITH ANY NOTED DEFECTS REMEDIATED, ON COMPLETION OF WORKS, TO THE SATISFACTION OF THE LOCAL AUTHORITY.
 - REFER TO ARCHITECTS DRAWINGS FOR DETAILS OF PRIVATE DRAINAGE
 - ALL COVER LEVELS ARE TO BE COORDINATED WITH ROAD DESIGN LEVELS AND LANDSCAPE ARCHITECT'S PROPOSED FINISH LEVELS.
 - THE INTERNAL BUILDING DRAINAGE TO BE COORDINATED WITH ARCHITECT'S LAYOUT.
 - ALL MANHOLE COVERS TO ROADWAYS SUBJECT TO TRAFFIC LOADINGS TO BE CLASS D400 OTHERWISE B125 GRADE

PROPOSED DRAINAGE LAYOUT

SCALE 1:250 @A1

NOTES:

CONTRACTOR TO ALLOW FOR JET WASHING ALL EXISTING FW AND SW DRAINS ON SITE FOLLOWED BY CCTV SURVEY OF ALL DRAINS ON SITE. CONTRACTOR TO PROVIDE 'AS BUILT' DRAWING OF ALL EXISTING AND PROPOSED DRAINS. REFER TO ARCHITECT'S DRAWINGS FOR FURTHER ADDITIONAL INSTRUCTIONS.

CONTRACTOR TO CARRY OUT A CCTV SURVEY OF NEW STORM WATER NETWORKS WITHIN THE PHASE 2 SITE BOUNDARY

| Rev No. | Date | Revision Note | Drn by | Chkd by |
|---------|------------|---|--------|---------|
| P01 | 03.02.23 | FOR INFORMATION | TD | TOD |
| P02 | 15.02.23 | DRAINAGE DETAILS ADDED FW & SW | TD | TOD |
| P03 | 02.03.2023 | DRAINAGE REVISED AS BUBBLED | TD | TOD |
| P04 | 26.06.23 | REDLINE BOUNDARY & SW LAYOUT UPDATED | AD | TD |
| P05 | 07.08.23 | DRAINAGE LAYOUT REVISED AS PER REVISED ARCHITECT LAYOUT | AD | TD |
| P06 | 16.08.23 | ISSUED FOR TENDER | AD | TD |

| Rev No. | Date | Revision Note | Drn by | Chkd by |
|---------|------|---------------|--------|---------|
| | | | | |
| | | | | |
| | | | | |
| | | | | |

- FOR SETTING OUT REFER TO ARCHITECT'S DRAWINGS.
- THIS DRAWING TO BE READ IN CONJUNCTION WITH ALL OTHER ARCHITECTURAL AND ENGINEERING DRAWINGS AND ALL OTHER RELEVANT DRAWINGS AND SPECIFICATIONS.
- DO NOT SCALE THIS DRAWING. USE FIGURED DIMENSIONS ONLY.
- NO PART OF THIS DOCUMENT MAY BE REPRODUCED OR TRANSMITTED IN ANY FORM OR STORED IN ANY RETRIEVAL SYSTEM OF ANY NATURE WITHOUT THE WRITTEN PERMISSION OF O'CONNOR SUTTON CRONIN AS COPYRIGHT HOLDER EXCEPT AS AGREED FOR USE ON THE PROJECT FOR WHICH THE DOCUMENT WAS ORIGINALLY ISSUED.

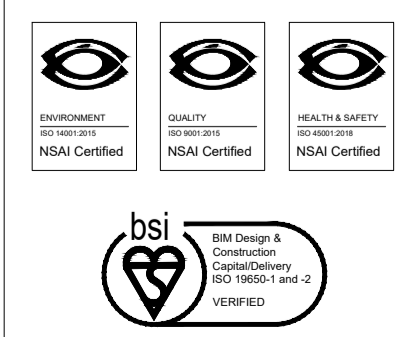

2nd Floor, Technology House,
Galway Technology Park,
Parkmore,
Galway.

TEL +353 (0)91 771360

e: galway@ocsc.ie
w: www.ocsc.ie

Dublin | London | Belfast | Galway | Cork | Birmingham



Client: SLIGO COUNTY COUNCIL
Project: ASH LANE GROUP HOUSING
Title: PROPOSED DRAINAGE LAYOUT

Code | Originator | Zone | Level | Type | Role | Number | Status | Revision
S603 - OCSC - XX - XX - DR - C - 0620 | D2 | P06
Date: JAN '23 Scale: 1:250 @ A1 Drn by: AD Chkd by: TD Aprvd by:

TENDER DRAWING
NOT FOR CONSTRUCTION
THIS DRAWING HAS BEEN ISSUED FOR INFORMATION PURPOSES ONLY AND MUST NOT BE USED FOR CONSTRUCTION UNDER ANY CIRCUMSTANCES

PRE-CAST CONCRETE MANHOLE WITH CAST IN-SITU BASE NOTES:

- ALL DIMENSIONS ARE IN MILLIMETRES (mm) UNLESS NOTED OTHERWISE.
- PRE-CAST MANHOLES UNITS: COMPLYING WITH REQUIREMENTS OF IS EN 1917 AND IS 420.
- THICKER MANHOLE BASES REQUIRED FOR SEWERS IN EXCESS OF 3m DEEP WHERE THE SIZE IS GREATER THAN THE STANDARD MINIMUM SIZE.
- APPROVED PRE-CAST CONCRETE BASES MAY BE USED INCORPORATING CHANNELS, BENCHING ETC. SUBJECT TO IRISH WATER REVIEW AND COMPLYING WITH IS EN 1719 AND IS 420.
- STRUCTURAL DESIGN AND REINFORCEMENT DETAILS TO BE PROVIDED BY THE DEVELOPER AND SUBMITTED TO IRISH WATER FOR REVIEW.
- MANHOLES GREATER THAN 3m IN DEPTH WILL REQUIRE A DETAILED STRUCTURAL DESIGN AND BE SUBJECT TO IRISH WATER REVIEW.
- MANHOLE ROOFS SHALL CONSIST OF A RE-INFORCED CONCRETE SLAB OF IN-SITU CONCRETE, C30/37, WITH A MINIMUM THICKNESS OF 225mm DESIGNED TO CARRY ALL LIVE AND DEAD LOADS. ALTERNATIVELY, APPROVED PRE-CAST CONCRETE ROOF SLABS MAY BE USED SUBJECT TO IRISH WATER REVIEW AND COMPLIANCE WITH IS EN 1917.
- COVERS AND FRAMES SHALL BE SUITABLE FOR ROAD AND TRAFFIC CONDITIONS SUBJECT TO REVIEW BY IRISH WATER.
- 200mm ALL AROUND x 100mm DEEP, C20/25 CONCRETE PLINCH COMPLETE WITH BULL NOSE FINISH AND TO BE PROVIDED COMPLETE WITH MILD STEEL REINFORCEMENT LINK AROUND COVERS IN GREEN AREAS.
- ALL CHAMBERS TO BE CHECKED FOR UPLIFT BY THE DEVELOPER BASED ON GROUND CONDITIONS WITHIN THE SITE. SHOULD ANTI FLOATION MEASURES BE REQUIRED THEY SHALL BE SUBJECT TO REVIEW BY IRISH WATER.
- ALL CONCRETE TO BE IN ACCORDANCE WITH IS EN 206 : 2013.
- ANY SPECIAL ROAD REINSTATEMENT AROUND COVER & FRAME SHALL BE TO ROAD AUTHORITY'S REQUIREMENTS.
- NEW ROAD CONSTRUCTION & SURFACE FINISH TO BE TO ROAD AUTHORITY REQUIREMENTS.
- EXISTING ROAD REINSTATEMENT TO COMPLY WITH CURRENT VERSION OF "GUIDELINES FOR MANAGING OPENINGS IN PUBLIC ROADS" BY THE DEPT. OF TRANSPORT, TOURISM & SPORT, OR TRANSPORT INFRASTRUCTURE IRELAND REQUIREMENTS.
- IF DEPTH FROM GROUND TO PIPE SOFFIT IS GREATER THAN 6m DEEP, A SITE SPECIFIC ENGINEERED SOLUTION FOR ACCESS SHALL BE PROVIDED. PROPRIETARY WATERTIGHT PCC MANHOLE RING SYSTEMS WITH A WALL THICKNESS > 125mm, & A WATER TIGHT JOINT SEALING SYSTEM, MAY BE USED WITHOUT CONCRETE SURROUND, SUBJECT TO THE GROUND WATER LEVEL AT THE MANHOLE BEING LOW, & SUBJECT TO REVIEW BY IRISH WATER.
- THE INTERNAL MANHOLE DIAMETERS SHOWN IN THE TABLE BELOW ARE MINIMUM DIMENSIONS AND WILL INCREASE DEPENDING ON THE NUMBER AND DIAMETER OF ADDITIONAL INLETS AND FINISHED WITH A 1:3 SAND/CEMENT FINISH TO SUIT FLOW OF INLETS AND OUTLET.

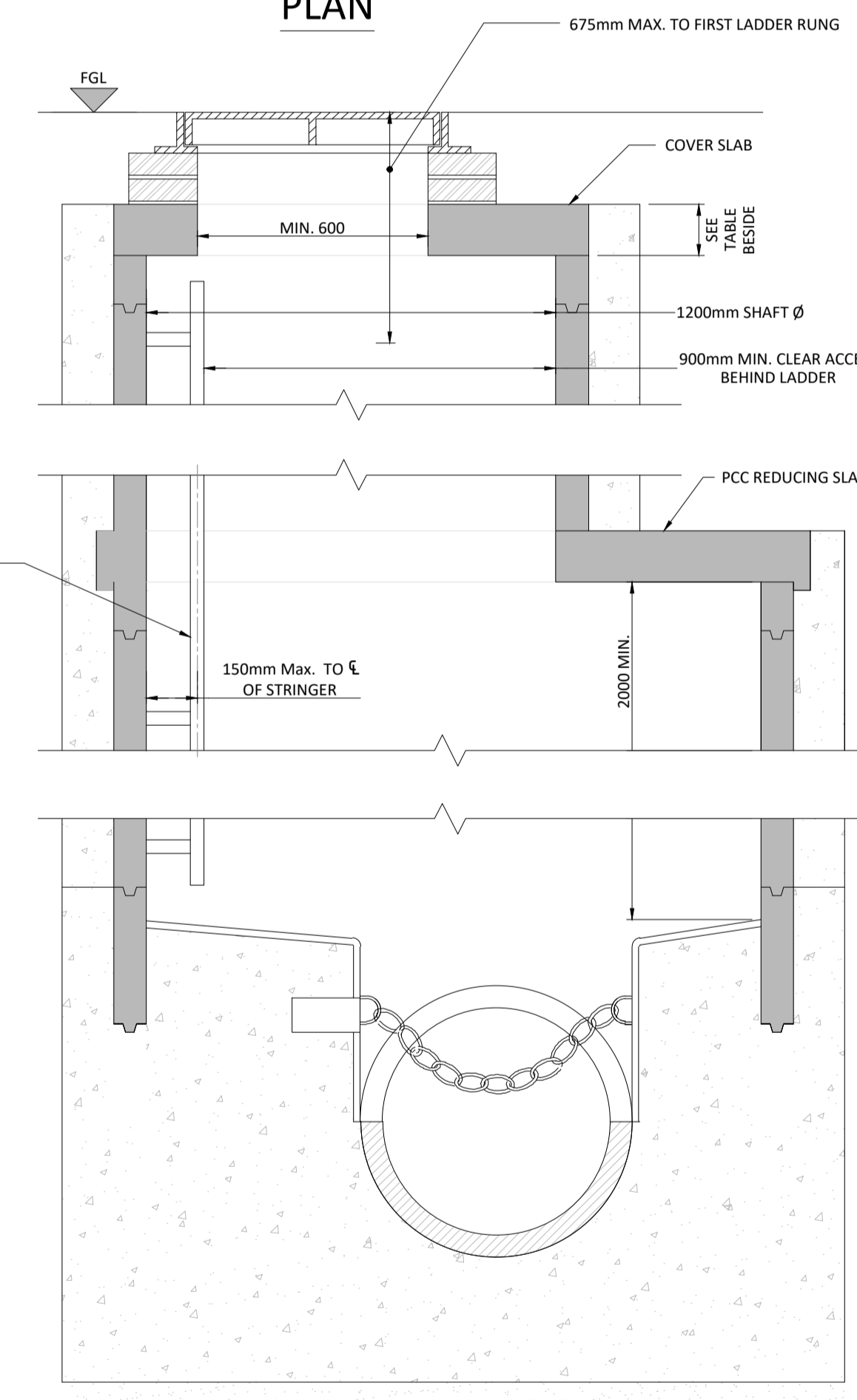
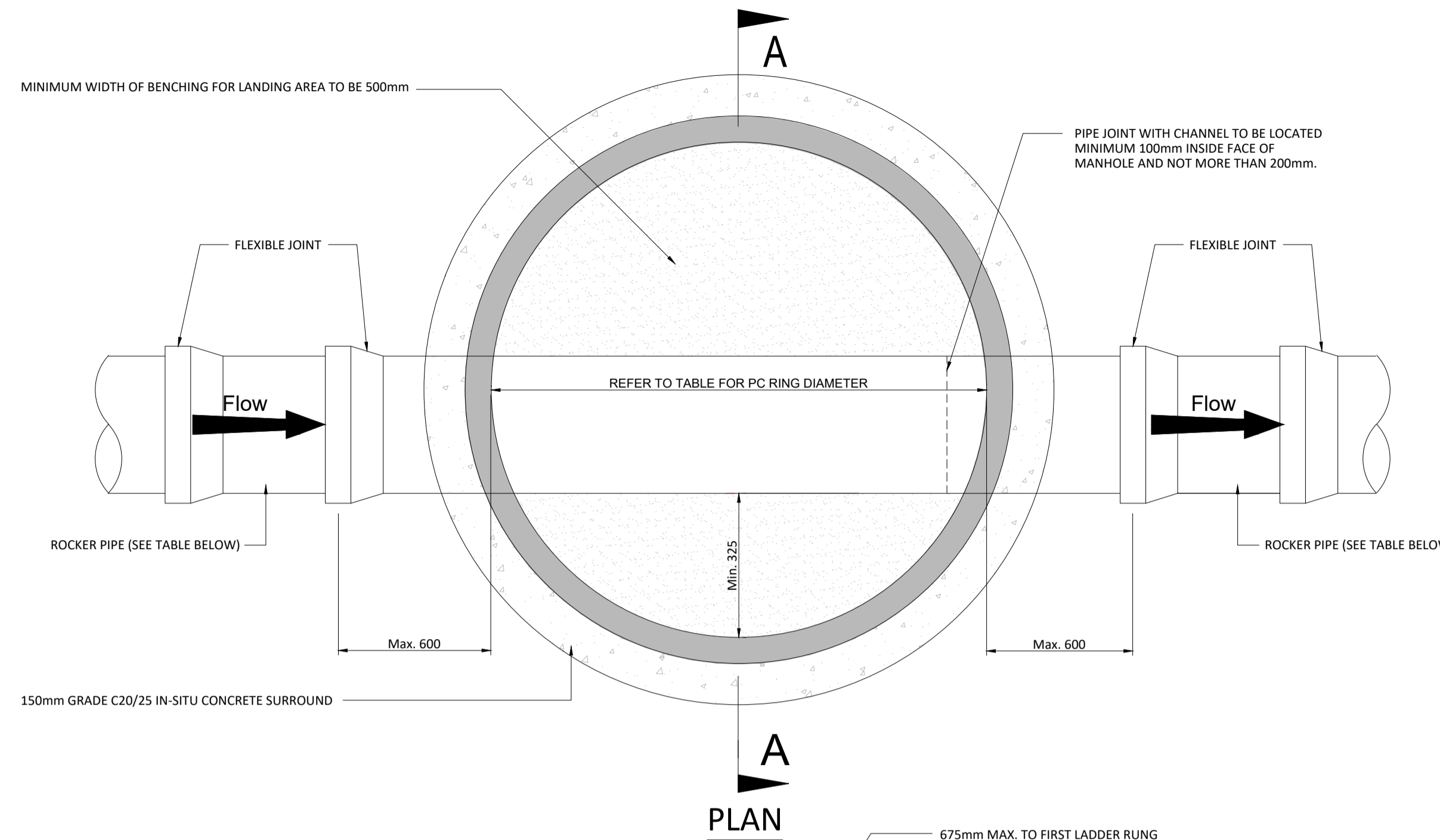

MANHOLE DETAIL > 3m & < 6m GROUND TO SOFFIT DEPTH

(NOTE: ON MANHOLES < 1.5m Ø, REDUCING SLAB NOT TO BE USED & PCC RINGS TO CONTINUE UP TO COVER SLAB)

| ROCKER PIPE LENGTH | |
|---------------------------|-------------------------|
| PIPE DIAMETER (mm) | ROCKER PIPE LENGTH (mm) |
| 150 TO 600 | 600 |
| GREATER THAN 600 TO 750 * | 1000 |
| GREATER THAN 750 * | 1250 |

* SEWERS GREATER THAN 450mm Ø ARE OUTSIDE THE SCOPE OF THE STANDARD DETAILS. MANHOLE SIZE OF THESE CHAMBERS MAY BE REQUIRED DUE TO MULTIPLE PIPES WITHIN MANHOLE.

NOTE:
PRE-CAST CONCRETE MANHOLES SHALL ONLY BE USED WHERE THE WATER TABLE IS LOW. THEY SHALL NOT BE USED WHERE THERE IS A PERCHED WATER TABLE, WHERE THE SEWER IS LOCATED NEXT TO A RIVER, LAKE OR OTHER WATER BODY AND WITHIN AREAS THAT ARE IDENTIFIED BY THE OFFICE OF PUBLIC WORKS CATCHMENT FLOOD RISK ASSESSMENT AND MANAGEMENT (CFRAM) WITH A FLOOD RISK OF 1 IN 10 YEARS.

COVER TO BE SET IN CEMENTITIOUS EPOXY RESIN/POLYESTER MORTAR 30N/mm²

MANHOLE COVER AND FRAME SHALL COMPLY TO IS EN 124 AND BS 7903 (ALL CLASS D400 COVERS SHALL HAVE MIN. FRAME DEPTH 100-150mm) MIN. DPE. 600x600mm or 600mm Ø.

SEE NOTES 13, 14 & 15.

FINISHED GROUND LEVEL

675mm MAX. TO FIRST STEP

2 - 4 COURSES OF CLASS B SOLID ENGINEERING BRICKS SET IN M30 MORTAR TO IS EN 998 (PROPRIETARY PRECAST RISER PIECES BEDDED ON M30 MORTAR MAY BE USED TO ACHIEVE CORRECT TOP OF COVER LEVEL 2 No. Max.)

MIN. 600

SEE TABLE BELOW

PRECAST CONCRETE MANHOLE RINGS TO IS 420 IN CONJUNCTION WITH IS EN 1917 : 2004

ELASTOMERIC JOINT SEAL TO EN 681

120

300 Z/C'S

REFER TO TABLE FOR PRE-CAST RING DIAMETER

MANHOLE STEPS TO COMPLY WITH IS EN 13101, TYPE D, CLASS 1, GALVANISED MILD STEEL & PLASTIC ENCAPSULATED. STEPS ARE REQUIRED IN MANHOLES UP TO A GROUND TO PIPE SOFFIT DEPTH OF LESS THAN 3.0m. MANHOLE LADDERS ARE REQUIRED FOR MANHOLES WITH A DEPTH IN EXCESS OF 3.0m & LADDERS ARE TO COMPLY WITH IS EN 14396.

150mm GRADE C20/25 IN-SITU CONCRETE SURROUND

BOTTOM PRECAST SECTION TO BE BUILT INTO BASE CONCRETE MIN. 75mm

CONSTRUCTION JOINT

1: 3 CEMENT-SAND MORTAR WITH STEEL TROWEL FINISH AT A 1:30 SLOPE TOWARDS THE CHANNEL

MIN. 50
MAX. 300

DISTANCE BETWEEN TOP OF PIPE & UNDERSIDE OF PRECAST SECTION TO BE MIN. 50mm TO MAX. 300mm

FIRST RING SUNK 100mm Min. INTO IN-SITU CONCRETE BASE

SELF CLEANING TOE HOLES TO BE PROVIDED WHERE CHANNEL EXCEEDS 600mm WIDE

REINFORCED CONCRETE BASE GRADE C30/37

STAINLESS STEEL CHAIN IN "DOWN" POSITION SECURED TO RESTRAINING HOOK, WHEN CHAMBER IS OCCUPIED WHERE THE PIPE DIAMETER IS 450mm OR MORE

INVERT SHOULD BE FORMED WITH CAST IN-SITU CONCRETE C25/30 20mm AGGREGATE FINISHED WITH A 1:3 CEMENT SAND MORTAR

75mm GRADE C12/15 BLINDING CONCRETE

TO BARREL OF PIPE

SECTION A-A

| MINIMUM MANHOLE DIAMETERS | | | |
|--|-----------------------------------|---|---------------------------------------|
| DIAMETER OF LARGEST PIPE IN MANHOLE (mm) | INTERNAL DIAMETER OF MANHOLE (mm) | MIN. PRECAST ROOF SLAB EFFECTIVE THICKNESS (mm) | MIN. IN-SITU ROOF SLAB THICKNESS (mm) |
| LESS THAN 375 | 1200 | 160 | 225 |
| 375 TO 450 | 1350 | 160 | 225 |
| 500 TO 750 * | 1500 | 170 | 225 |

SURFACE WATER AND WASTEWATER STANDARD DETAILS

SCALE 1:10

- FOR SETTING OUT REFER TO ARCHITECT'S DRAWINGS.
- THIS DRAWING TO BE READ IN CONJUNCTION WITH ALL OTHER ARCHITECTURAL AND ENGINEERING DRAWINGS AND ALL OTHER RELEVANT DRAWINGS AND SPECIFICATIONS.
- DO NOT SCALE THIS DRAWING. USE FIGURED DIMENSIONS ONLY.
- NO PART OF THIS DOCUMENT MAY BE REPRODUCED OR TRANSMITTED IN ANY FORM OR STORED IN ANY RETRIEVAL SYSTEM OF ANY NATURE WITHOUT THE WRITTEN PERMISSION OF O'CONNOR SUTTON CRONIN AS COPYRIGHT HOLDER EXCEPT AS AGREED FOR USE ON THE PROJECT FOR WHICH THE DOCUMENT WAS ORIGINALLY ISSUED.

| Rev No. | Date | Revision Note | Drn by | Chkd by |
|---------|----------|-------------------|--------|---------|
| P01 | 16.02.23 | FOR INFORMATION | TD | TOD |
| P02 | 16.08.23 | ISSUED FOR TENDER | AD | TD |

| Rev No. | Date | Revision Note | Drn by | Chkd by |
|---------|------|---------------|--------|---------|
| | | | | |
| | | | | |



2nd Floor, Technology House,
Galway Technology Park,
Parkmore,
Galway.

TEL +353 (0)91 771360

e: galway@ocsc.ie
w: www.ocsc.ie

Dublin | London | Belfast | Galway | Cork | Birmingham



Client: SLIGO COUNTY COUNCIL
Project: ASH LANE GROUP HOUSING

Title: SURFACE AND WASTEWATER STANDARD DETAILS
SHEET 1 OF 5

Code | Originator | Zone | Level | Type | Role | Number | Status | Revision
S603 - OCSC - XX - XX - DR - C - 0620 | D2 | P02
Date: FEB '23 Scale: A:N. @ A1 Drn by: AD Chkd by: TD Aprvd by:

TENDER DRAWING

NOT FOR CONSTRUCTION

THIS DRAWING HAS BEEN ISSUED FOR INFORMATION PURPOSES ONLY AND MUST NOT BE USED FOR CONSTRUCTION UNDER ANY CIRCUMSTANCES

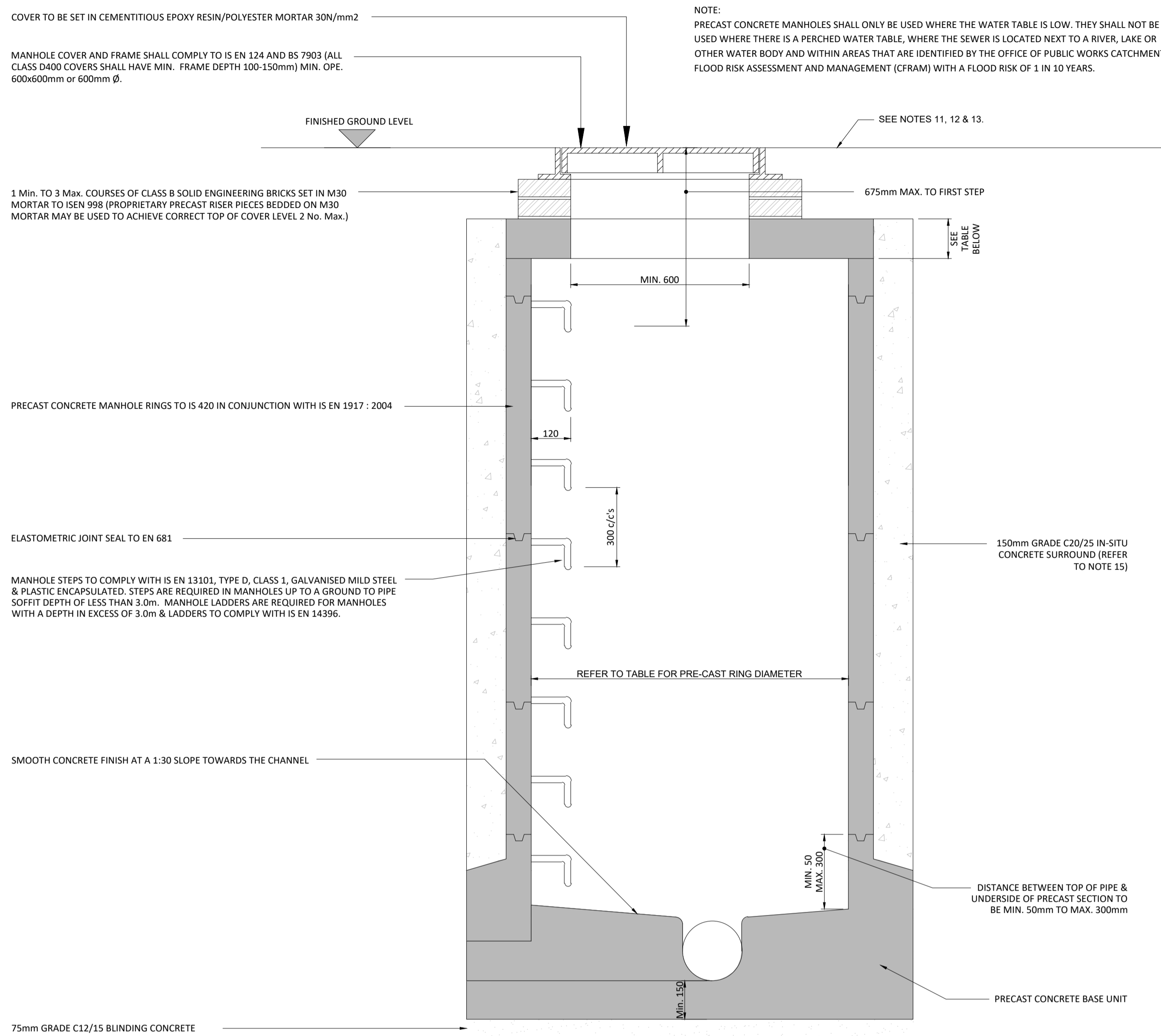

SECTION A-A

| MINIMUM MANHOLE DIAMETERS | | | |
|--|-----------------------------------|---|---------------------------------------|
| DIAMETER OF LARGEST PIPE IN MANHOLE (mm) | INTERNAL DIAMETER OF MANHOLE (mm) | MIN. PRECAST ROOF SLAB EFFECTIVE THICKNESS (mm) | MIN. IN-SITU ROOF SLAB THICKNESS (mm) |
| LESS THAN 375 | 1200 | 160 | 225 |
| 375 TO 450 | 1350 | 160 | 225 |
| 500 TO 750 | 1500 | 170 | 225 |

SURFACE WATER AND WASTEWATER STANDARD DETAILS
SCALE 1:10

- FOR SETTING OUT REFER TO ARCHITECT'S DRAWINGS.
- THIS DRAWING TO BE READ IN CONJUNCTION WITH ALL OTHER ARCHITECTURAL AND ENGINEERING DRAWINGS AND ALL OTHER RELEVANT DRAWINGS AND SPECIFICATIONS.
- DO NOT SCALE THIS DRAWING. USE FIGURED DIMENSIONS ONLY.
- NO PART OF THIS DOCUMENT MAY BE REPRODUCED OR TRANSMITTED IN ANY FORM OR STORED IN ANY RETRIEVAL SYSTEM OF ANY NATURE WITHOUT THE WRITTEN PERMISSION OF O'CONNOR SUTTON CRONIN AS COPYRIGHT HOLDER EXCEPT AS AGREED FOR USE ON THE PROJECT FOR WHICH THE DOCUMENT WAS ORIGINALLY ISSUED.

| Rev No. | Date | Revision Note | Drn by | Chkd by |
|---------|----------|-------------------|--------|---------|
| P01 | 16.02.23 | FOR INFORMATION | TD | TOD |
| P02 | 16.08.23 | ISSUED FOR TENDER | AD | TD |

| Rev No. | Date | Revision Note | Drn by | Chkd by |
|---------|------|---------------|--------|---------|
| | | | | |
| | | | | |

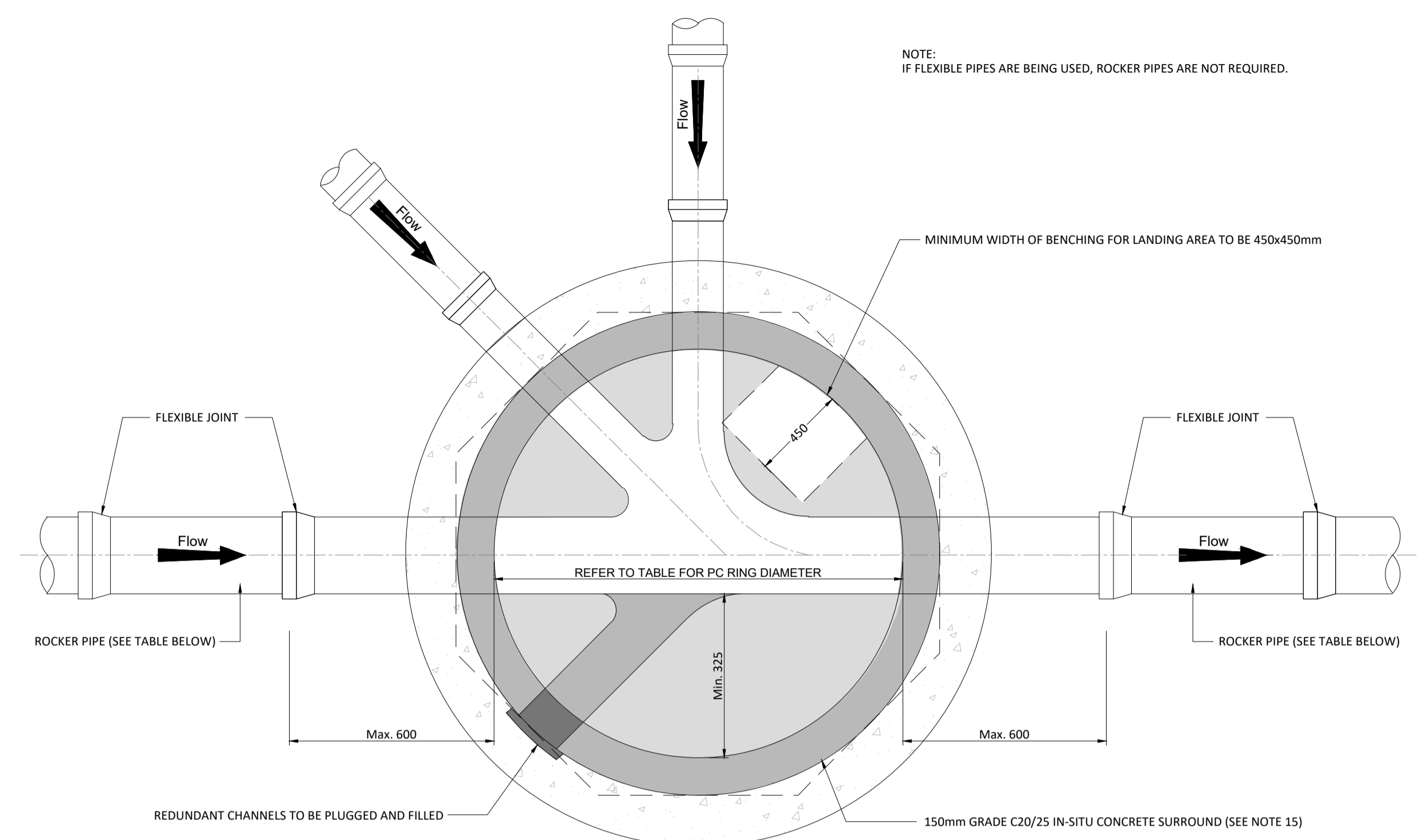

PLAN

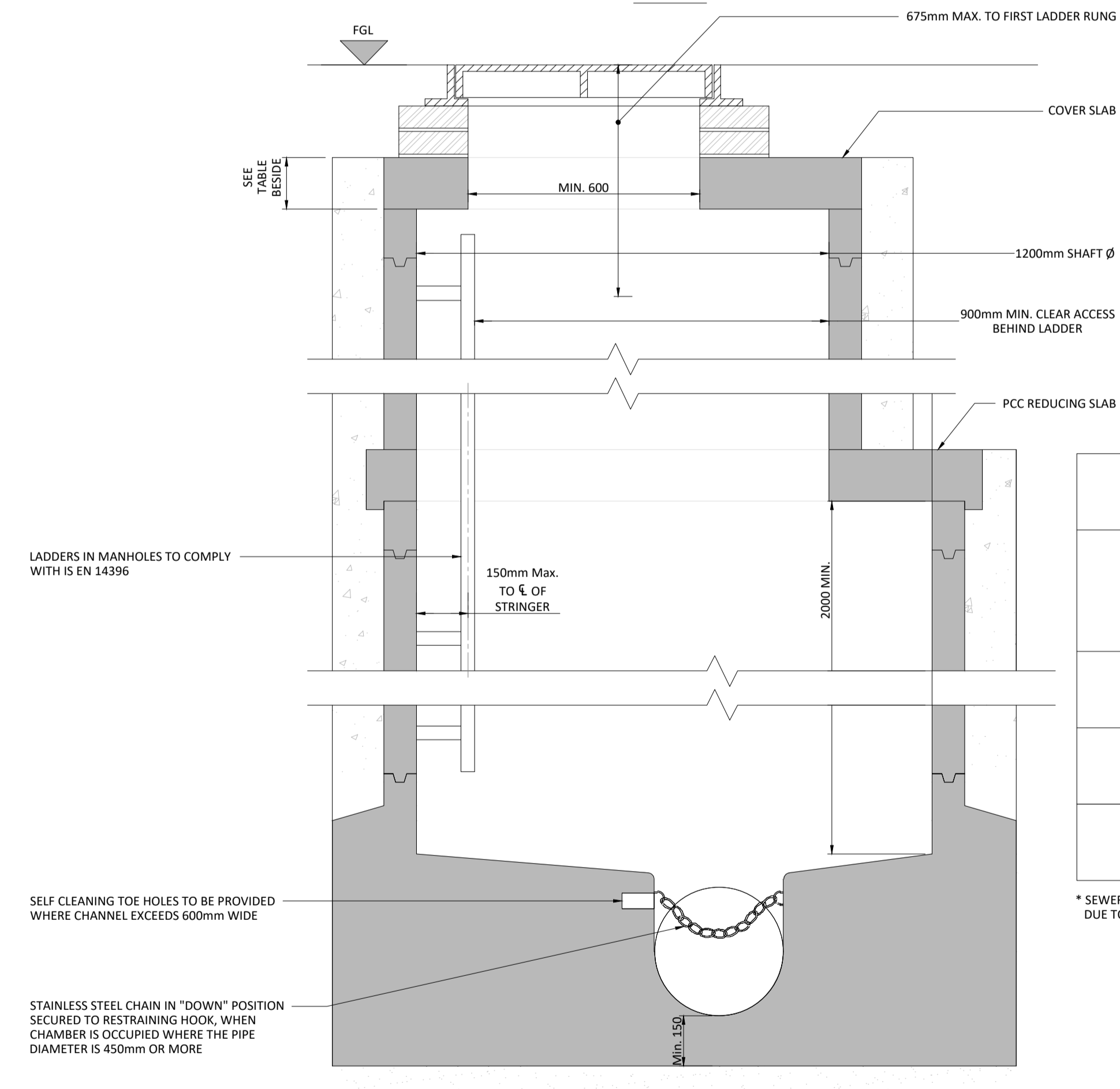

MANHOLE DETAIL > 3m & < 6m GROUND TO SOFFIT DEPTH

(NOTE: ON MANHOLES <1.5mØ, REDUCING SLAB NOT TO BE USED & PCC RINGS TO CONTINUE UP TO COVER SLAB)

| ROCKER PIPE LENGTH | |
|-------------------------|-------------------------|
| PIPE DIAMETER (mm) | ROCKER PIPE LENGTH (mm) |
| 150 TO 600 | 600 |
| GREATER THAN 600 TO 750 | 1000 |
| GREATER THAN 750 | 1250 |

* SEWERS GREATER THAN 450mm Ø ARE OUTSIDE THE SCOPE OF THE STANDARD DETAILS. MANHOLE SIZE OF THESE CHAMBERS MAY BE REQUIRED DUE TO MULTIPLE PIPES WITHIN MANHOLE.

PRE-CAST CONCRETE MANHOLE WITH PRECAST BASE NOTES:

- ALL DIMENSIONS ARE IN MILLIMETRES (mm) UNLESS NOTED OTHERWISE.
- PRE-CAST MANHOLES UNITS: COMPLYING WITH REQUIREMENTS OF IS EN 1917 AND IS 420.
- PRE-CAST CONCRETE BASE INCORPORATING CHANNELS, BENCHING ETC. SUBJECT TO IRISH WATER REVIEW AND COMPLYING WITH IS EN 1917 & IS 420.
- IN SITUATIONS WHERE P.C.C. MANHOLE BASES HAVE REDUNDANT CHANNELS, THESE SHALL BE PLUGGED AND FILLED BY SCABBLING, AND INFILLED WITH GRADE C20/25 CONCRETE TO MATCH EXISTING BASE AND BENCHING TO SUIT FLOW WITHIN THE MANHOLE BASE.
- MANHOLES GREATER THAN 3m IN DEPTH WILL REQUIRE A DETAILED STRUCTURAL DESIGN AND BE SUBJECT TO IRISH WATER REVIEW.
- PRE-CAST CONCRETE ROOF SLABS TO BE USED SUBJECT TO IRISH WATER REVIEW AND COMPLIANCE WITH IS 420.
- COVERS AND FRAMES SHALL BE SUITABLE FOR ROAD AND TRAFFIC CONDITIONS SUBJECT TO REVIEW BY IRISH WATER.
- 200mm ALL AROUND x 100mm DEEP, C20/25 CONCRETE PLINTH COMPLETE WITH BULL NOSE FINISH AND TO BE PROVIDED COMPLETE WITH MILD STEEL REINFORCEMENT LINK AROUND COVERS IN GREEN AREAS.
- ALL CHAMBERS TO BE CHECKED FOR UPLIFT BY THE DEVELOPER BASED ON GROUND CONDITIONS WITHIN THE SITE. SHOULD ANTI FLOTATION MEASURES BE REQUIRED THEY SHALL BE SUBJECT TO REVIEW BY IRISH WATER.
- ALL CONCRETE TO BE IN ACCORDANCE WITH IS EN 206 : 2013.
- ANY SPECIAL ROAD REINSTATEMENT AROUND COVER & FRAME SHALL BE TO ROAD AUTHORITY'S REQUIREMENTS.
- NEW ROAD CONSTRUCTION & SURFACE FINISH TO BE TO ROAD AUTHORITY REQUIREMENTS.
- EXISTING ROAD REINSTATEMENT TO COMPLY WITH CURRENT VERSION OF "GUIDELINES FOR MANAGING OPENINGS IN PUBLIC ROADS" BY THE DEPT. OF TRANSPORT, TOURISM & SPORT, OR "TRANSPORT INFRASTRUCTURE IRELAND REQUIREMENTS".
- IF DEPTH FROM GROUND TO PIPE SOFFIT IS GREATER THAN 6m DEEP, A SITE SPECIFIC ENGINEERED SOLUTION FOR ACCESS SHALL BE PROVIDED.
- PROPRIETARY WATERTIGHT PCC MANHOLE RING SYSTEMS WITH A WALL THICKNESS > 125mm, & A WATER TIGHT JOINT SEALING SYSTEM, MAY BE USED WITHOUT CONCRETE SURROUND, SUBJECT TO THE GROUND WATER LEVEL AT THE MANHOLE BEING LOW, & SUBJECT TO REVIEW BY IRISH WATER.
- THE INTERNAL MANHOLE DIAMETERS SHOWN IN THE TABLE BELOW ARE MINIMUM DIMENSIONS AND WILL INCREASE DEPENDING ON THE NUMBER AND DIAMETER OF ADDITIONAL INLETS AND FINISHED WITH A 1:3 SAND/CEMENT FINISH TO SUIT FLOW OF INLETS AND OUTLET.

TENDER DRAWING
NOT FOR CONSTRUCTION
THIS DRAWING HAS BEEN ISSUED FOR INFORMATION PURPOSES ONLY AND MUST NOT BE USED FOR CONSTRUCTION UNDER ANY CIRCUMSTANCES

SLIGO COUNTY COUNCIL
2nd Floor, Technology House, Galway Technology Park, Parkmore, Galway.
TEL +353 (0)91 771360
e: galway@ocsc.ie
w: www.ocsc.ie
Dublin | London | Belfast | Galway | Cork | Birmingham

OCSC
O'CONNOR | SUTTON | CRONIN
Multidisciplinary Consulting Engineers

Client: SLIGO COUNTY COUNCIL
Project: ASH LANE GROUP HOUSING
Title: SURFACE AND WASTEWATER STANDARD DETAILS SHEET 2 OF 5

| | | | | | | | | |
|------|------------|------|-------|------|------|--------|--------|----------|
| Code | Originator | Zone | Level | Type | Role | Number | Status | Revision |
| S603 | OCSC | XX | XX | DR | C | 0622 | D2 | P02 |

Date: FEB '23 Scale: A.N. @ A1 Drn by: AD Chkd by: TD Aprvd by:

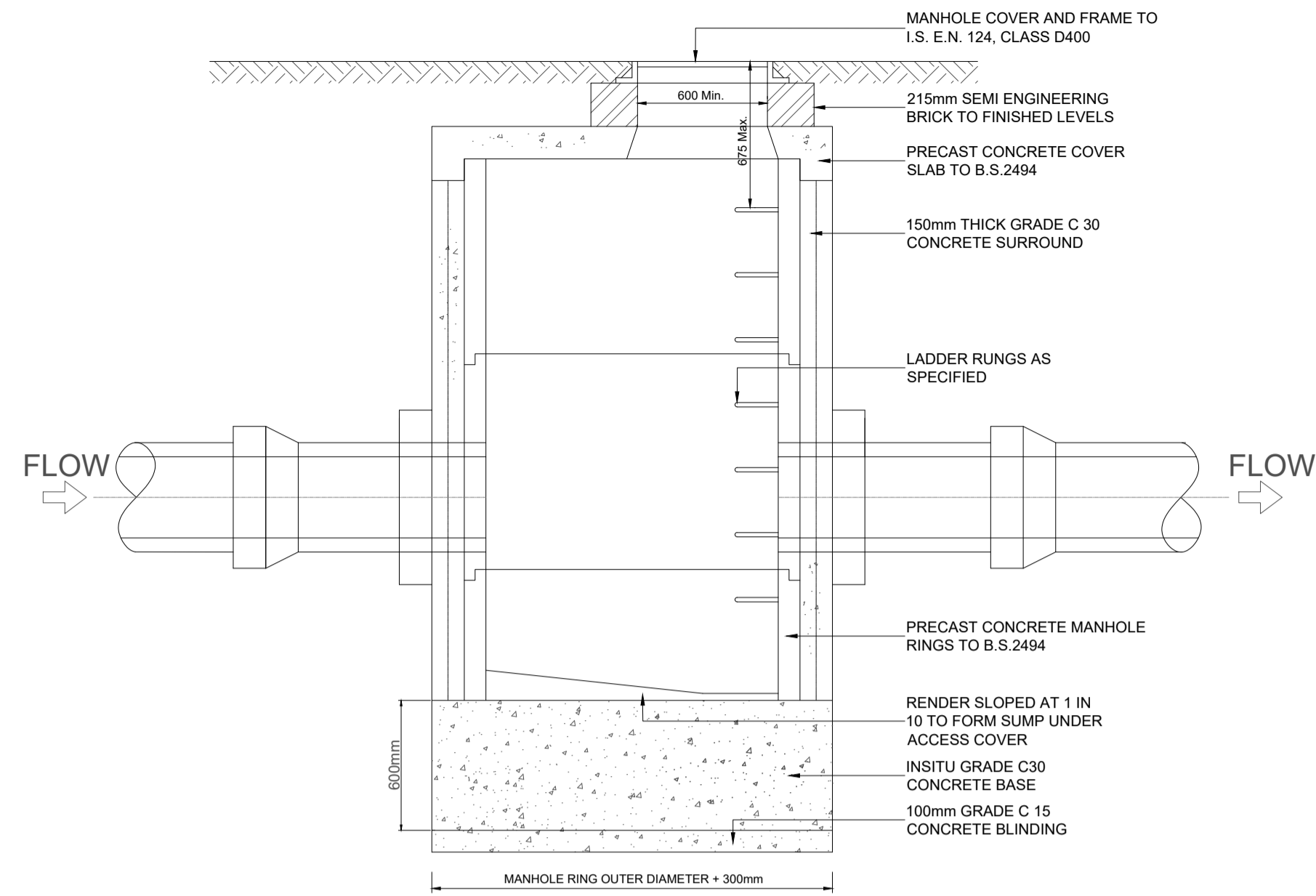

TYPICAL SILT TRAP
MAX. DEPTH G.L. TO I.L. - 3.0m
SCALE 1:25

| REF. NO. | FLOW (l/s) | DRAINAGE AREA | SILT STORAGE CAPACITY LITRES | OIL STORAGE CAPACITY LITRES | LENGTH (L) (mm) | UNIT DIA (D) (mm) | MANHOLE COVER (D1) (mm) | BASE TO INVERT (A) (mm) | BASE TO OUTLET (B) (mm) | MIN. INLET INVERT. (E) (mm) | STANDARD PIPEWORK DIA. (C) (mm) | STANDARD FALL ACROSS (mm) |
|----------|------------|---------------|------------------------------|-----------------------------|-----------------|-------------------|-------------------------|-------------------------|-------------------------|-----------------------------|---------------------------------|---------------------------|
| NSBP003 | 3 | 1670 | 300 | 45 | 1700 | 1350 | 600 | 1760 | 1660 | 500 | 315 | 100 |

TYPICAL SIZE OF KLARGESTER CLASS 1 INTERCEPTOR

(Subject to planning, unit dimensions & surround provided at detailed design stage).

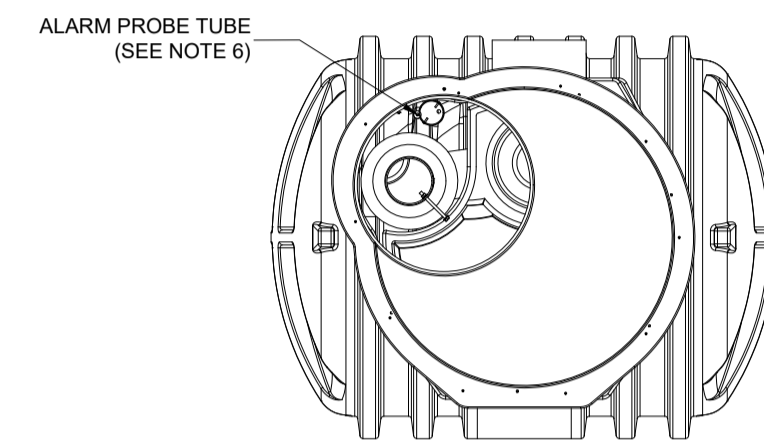

KLARGESTER CLASS 1 INTERCEPTOR
PLAN VIEW
OR SIMILAR APPROVED
SCALE 1:25

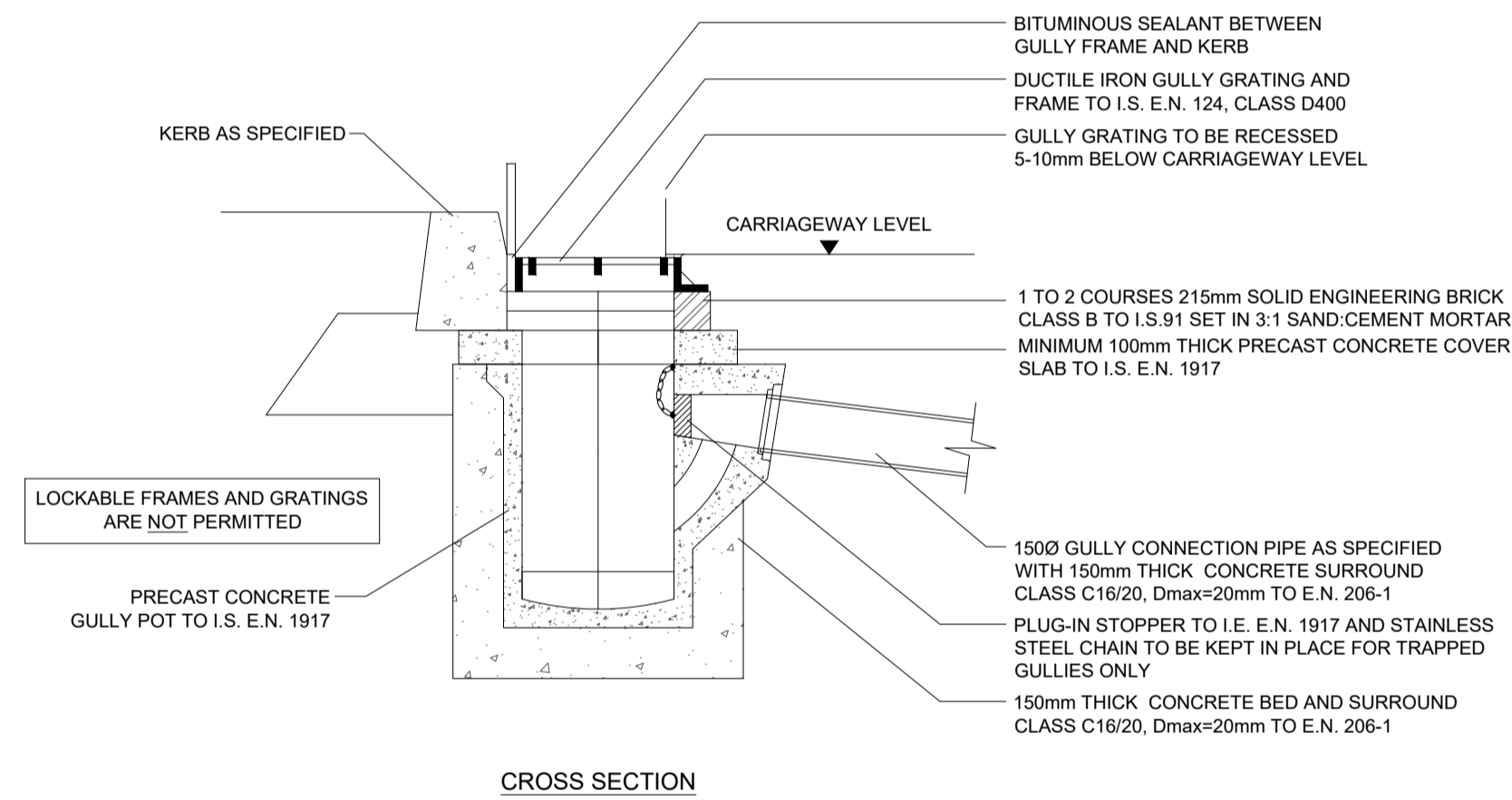

CROSS SECTION

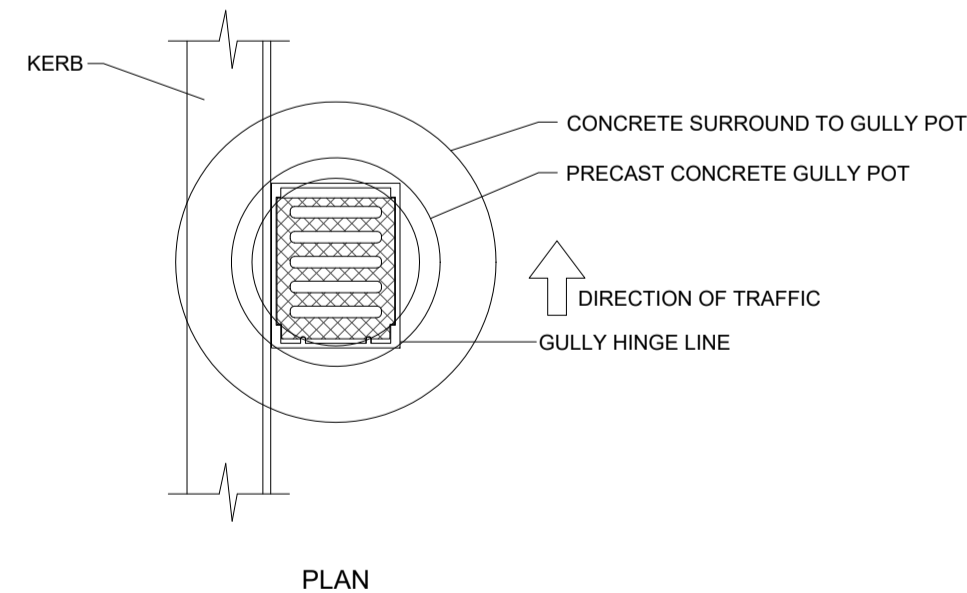

PLAN

PRECAST CONCRETE ROAD GULLY

SCALE: 1:20

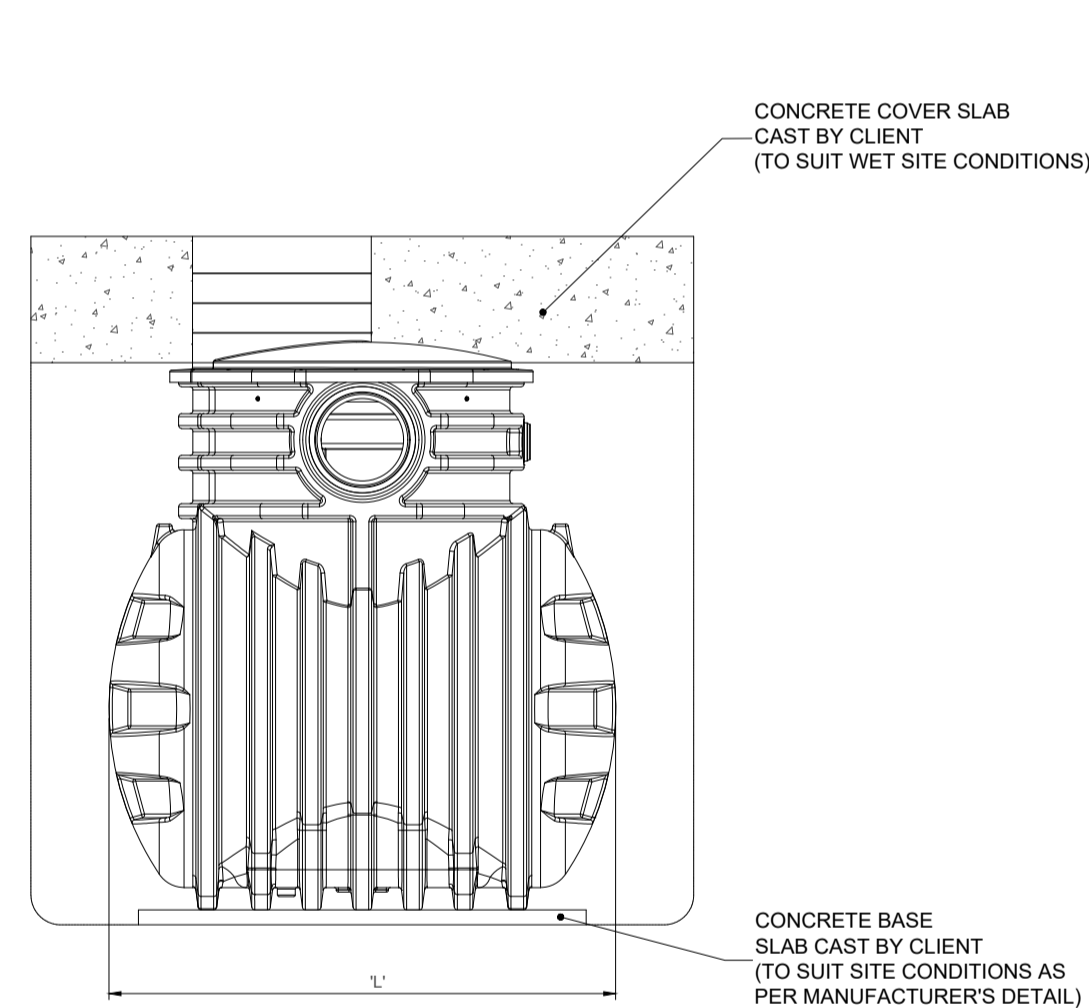

KLARGESTER CLASS 1 INTERCEPTOR
SECTION B - B
OR SIMILAR APPROVED
SCALE 1:25

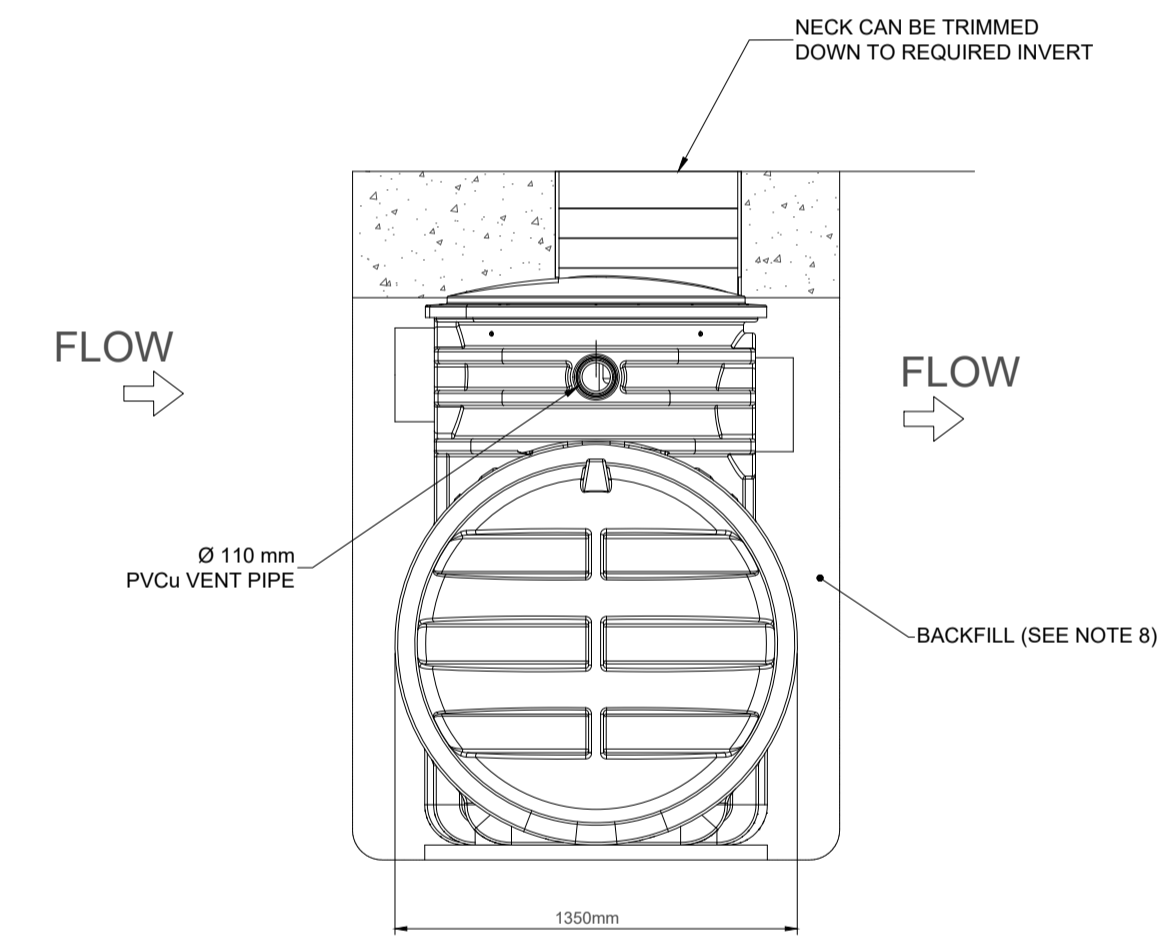

KLARGESTER CLASS 1 INTERCEPTOR
SECTION A-A
OR SIMILAR APPROVED
SCALE 1:25

NOTES:

- INLET / OUTLET PIPES ARE PLAIN PIPE Ø315mm PVCu. THE STANDARD EN 858 STATES MINIMUM CONNECTION SIZES. UNITS ORDERED WITH DIFFERENT SIZED CONNECTIONS ARE NOT FULLY COMPLIANT WITH THE STANDARD.
- EXTENSION NECKS FOR DEEPER INVERTS CAN BE PROVIDED. THESE CAN BE CUT IN 200mm SECTIONS. MAX. 2.0m INVERT RECOMMENDED. PLEASE ASK OUR SALES DEPARTMENT FOR FURTHER DETAILS.
- ALL UNITS REQUIRE APPROPRIATE COVER AND FRAME TO SUIT APPLIED LOADINGS.
- THIS DRAWING SHOULD BE USED FOR DIMENSIONAL INFORMATION ONLY. IT IS ESSENTIAL THAT THIS DRAWING IS READ IN CONJUNCTION WITH THE INSTALLATION GUIDELINES SUPPLIED WITH THE UNIT. (COPIES ARE AVAILABLE FROM OUR SALES DEPT.).
- THIS DRAWING IS ALSO AVAILABLE ON OUR WEBSITE www.kingspanenv.com.
- A Ø76 mm TUBE (INTERNAL) IS SUPPLIED TO HOUSE AN OIL ALARM PROBE.
- WET SITE CONDITIONS - CONCRETE BACKFILL DRY SITE CONDITIONS - PEA SHINGLE BACKFILL. PLEASE REFER TO INSTALLATION MANUAL FOR DETAILS OF CORRECT BACKFILLING.

SURFACE WATER AND WASTEWATER STANDARD DETAILS

SCALE AS SHOWN

- FOR SETTING OUT REFER TO ARCHITECT'S DRAWINGS.
- THIS DRAWING TO BE READ IN CONJUNCTION WITH ALL OTHER ARCHITECTURAL AND ENGINEERING DRAWINGS AND ALL OTHER RELEVANT DRAWINGS AND SPECIFICATIONS.
- DO NOT SCALE THIS DRAWING. USE FIGURED DIMENSIONS ONLY.
- NO PART OF THIS DOCUMENT MAY BE REPRODUCED OR TRANSMITTED IN ANY FORM OR STORED IN ANY RETRIEVAL SYSTEM OF ANY NATURE WITHOUT THE WRITTEN PERMISSION OF O'CONNOR SUTTON CRONIN AS COPYRIGHT HOLDER EXCEPT AS AGREED FOR USE ON THE PROJECT FOR WHICH THE DOCUMENT WAS ORIGINALLY ISSUED.

| Rev No. | Date | Revision Note | Drn by | Chkd by |
|---------|----------|-------------------|--------|---------|
| P01 | 16.02.23 | FOR INFORMATION | TD | TOD |
| P02 | 16.08.23 | ISSUED FOR TENDER | AD | TD |

| Rev No. | Date | Revision Note | Drn by | Chkd by |
|---------|------|---------------|--------|---------|
| | | | | |
| | | | | |
| | | | | |



2nd Floor, Technology House,
Galway Technology Park,
Parkmore,
Galway.

TEL +353 (0)91 771360

e: galway@ocsc.ie
w: www.ocsc.ie

Dublin | London | Belfast | Galway | Cork | Birmingham



Client: SLIGO COUNTY COUNCIL
Project: ASH LANE GROUP HOUSING

Title: SURFACE AND WASTEWATER STANDARD DETAILS
SHEET 3 OF 5

Code | Originator | Zone | Level | Type | Role | Number | Status | Revision
S603 - OCSC - XX - XX - DR - C - 0623 | D2 | P02
Date: FEB '23 Scale: A.N. @ A1 Drn by: AD Chkd by: TD Aprvd by:

TENDER DRAWING
NOT FOR CONSTRUCTION

THIS DRAWING HAS BEEN ISSUED FOR INFORMATION PURPOSES ONLY AND MUST NOT BE USED FOR CONSTRUCTION UNDER ANY CIRCUMSTANCES

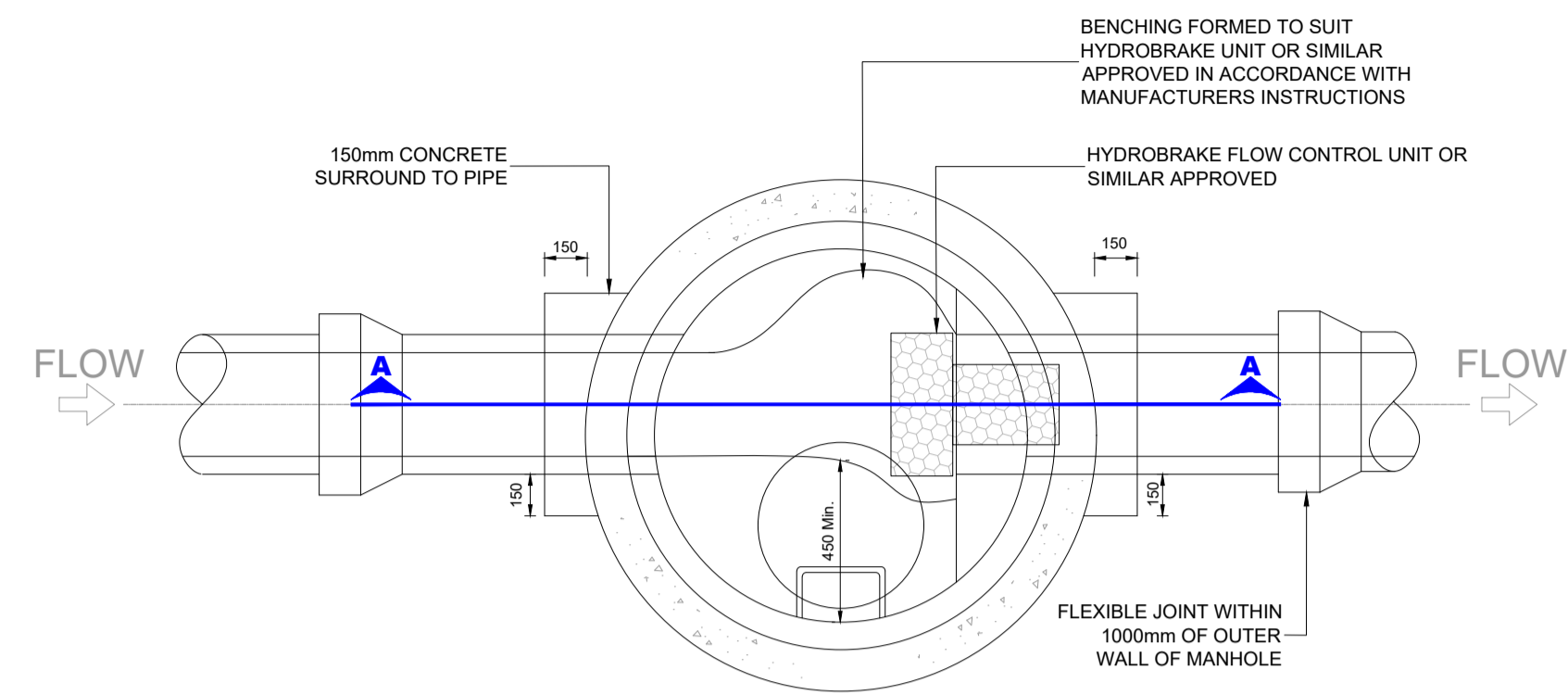

FLOW CONTROL CHAMBER

MAX. DEPTH G.L. TO I.L. - 3.0m
SCALE 1:25

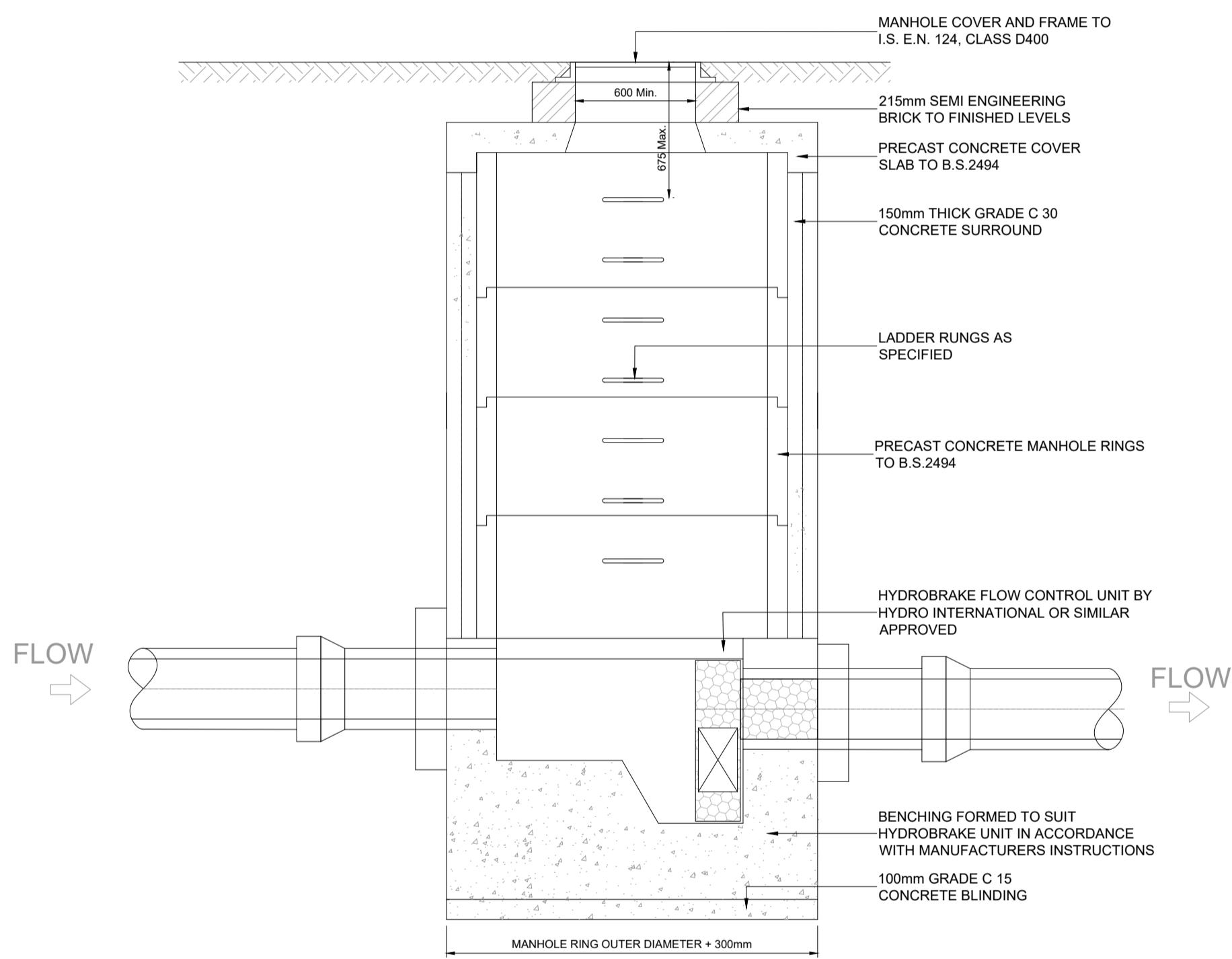

FLOW CONTROL CHAMBER - SECTION A-A

MAX. DEPTH G.L. TO I.L. - 3.0m
SCALE 1:25

SURFACE WATER AND WASTEWATER STANDARD DETAILS

SCALE AS SHOWN

- FOR SETTING OUT REFER TO ARCHITECT'S DRAWINGS.
- THIS DRAWING TO BE READ IN CONJUNCTION WITH ALL OTHER ARCHITECTURAL AND ENGINEERING DRAWINGS AND ALL OTHER RELEVANT DRAWINGS AND SPECIFICATIONS.
- DO NOT SCALE THIS DRAWING. USE FIGURED DIMENSIONS ONLY.
- NO PART OF THIS DOCUMENT MAY BE REPRODUCED OR TRANSMITTED IN ANY FORM OR STORED IN ANY RETRIEVAL SYSTEM OF ANY NATURE WITHOUT THE WRITTEN PERMISSION OF O'CONNOR SUTTON CRONIN AS COPYRIGHT HOLDER EXCEPT AS AGREED FOR USE ON THE PROJECT FOR WHICH THE DOCUMENT WAS ORIGINALLY ISSUED.

| Rev No. | Date | Revision Note | Drn by | Chkd by |
|---------|----------|-------------------|--------|---------|
| P01 | 16.02.23 | FOR INFORMATION | TD | TOD |
| P02 | 16.08.23 | ISSUED FOR TENDER | AD | TD |

| Rev No. | Date | Revision Note | Drn by | Chkd by |
|---------|------|---------------|--------|---------|
| | | | | |

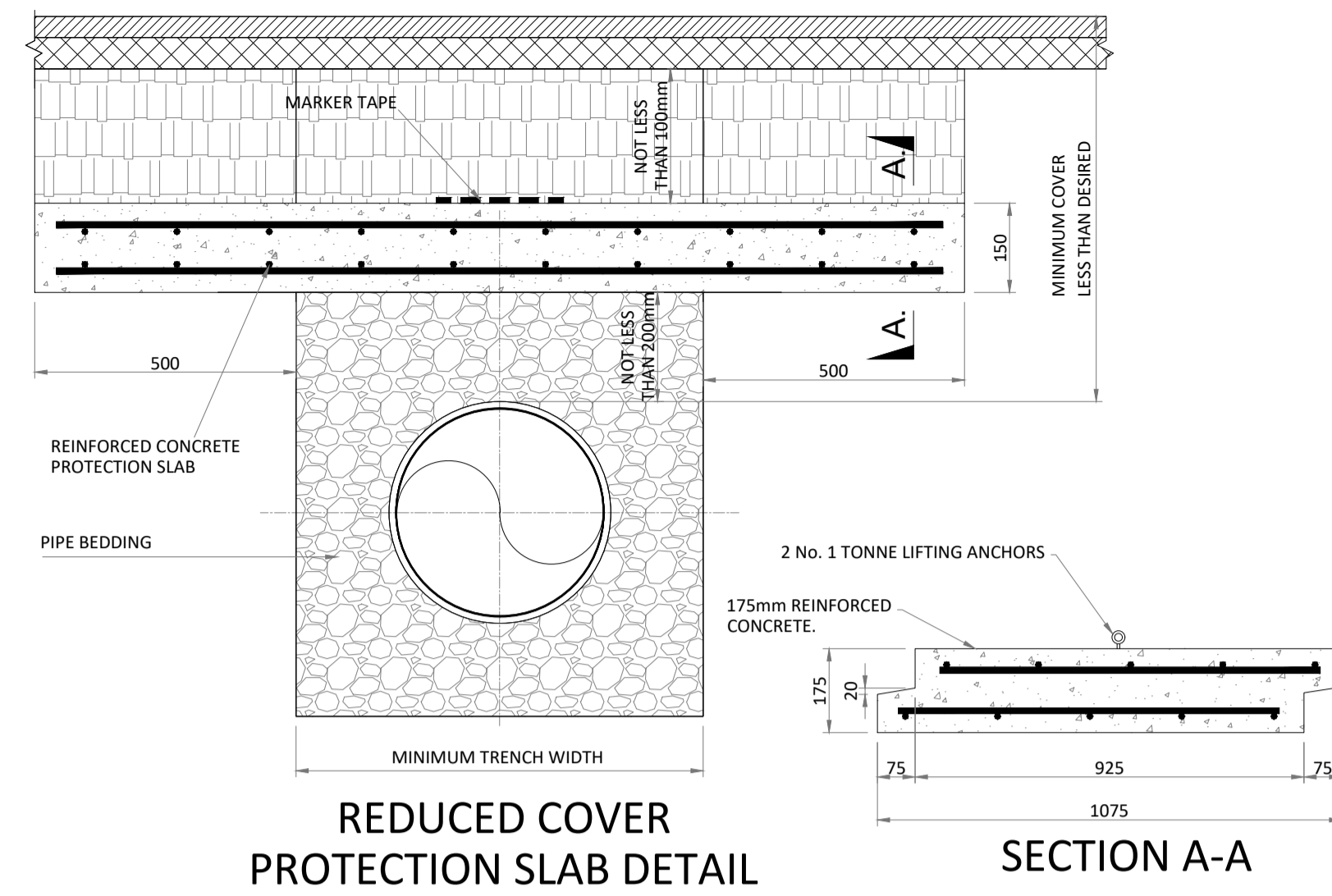

REDUCED COVER PROTECTION SLAB DETAIL

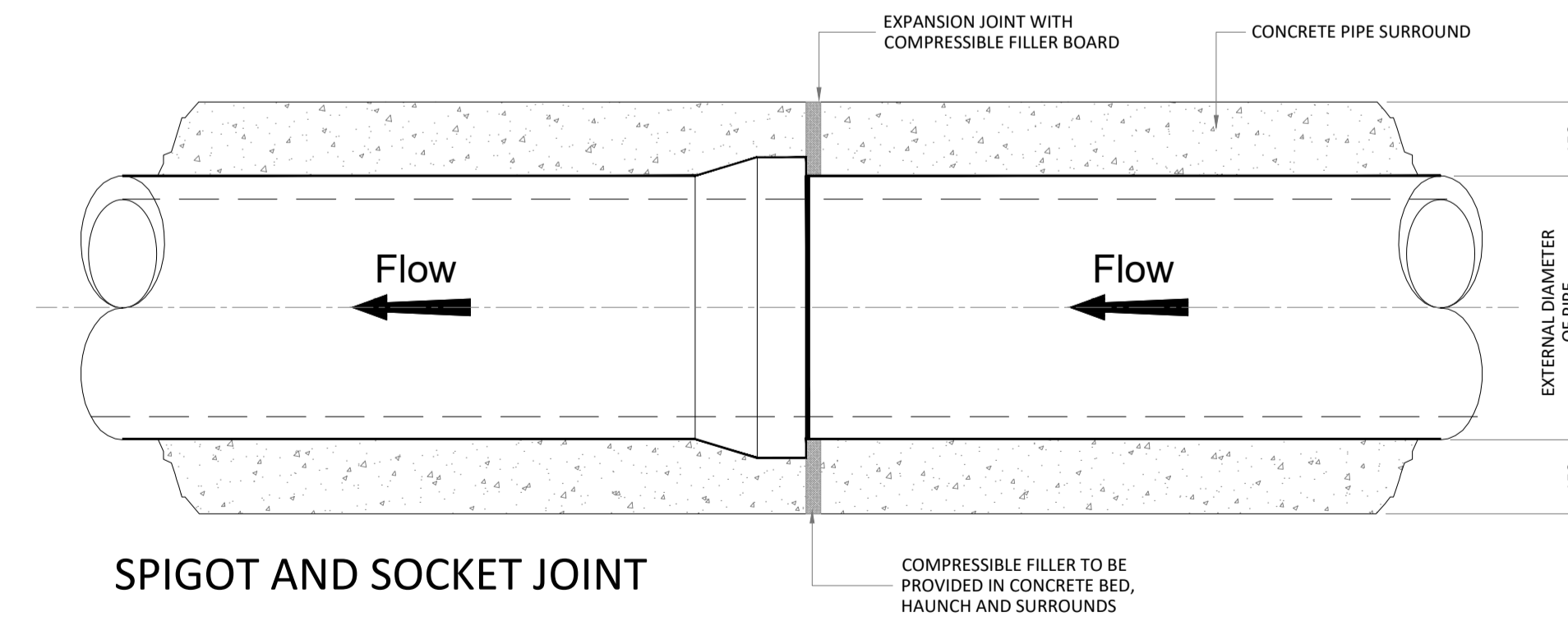
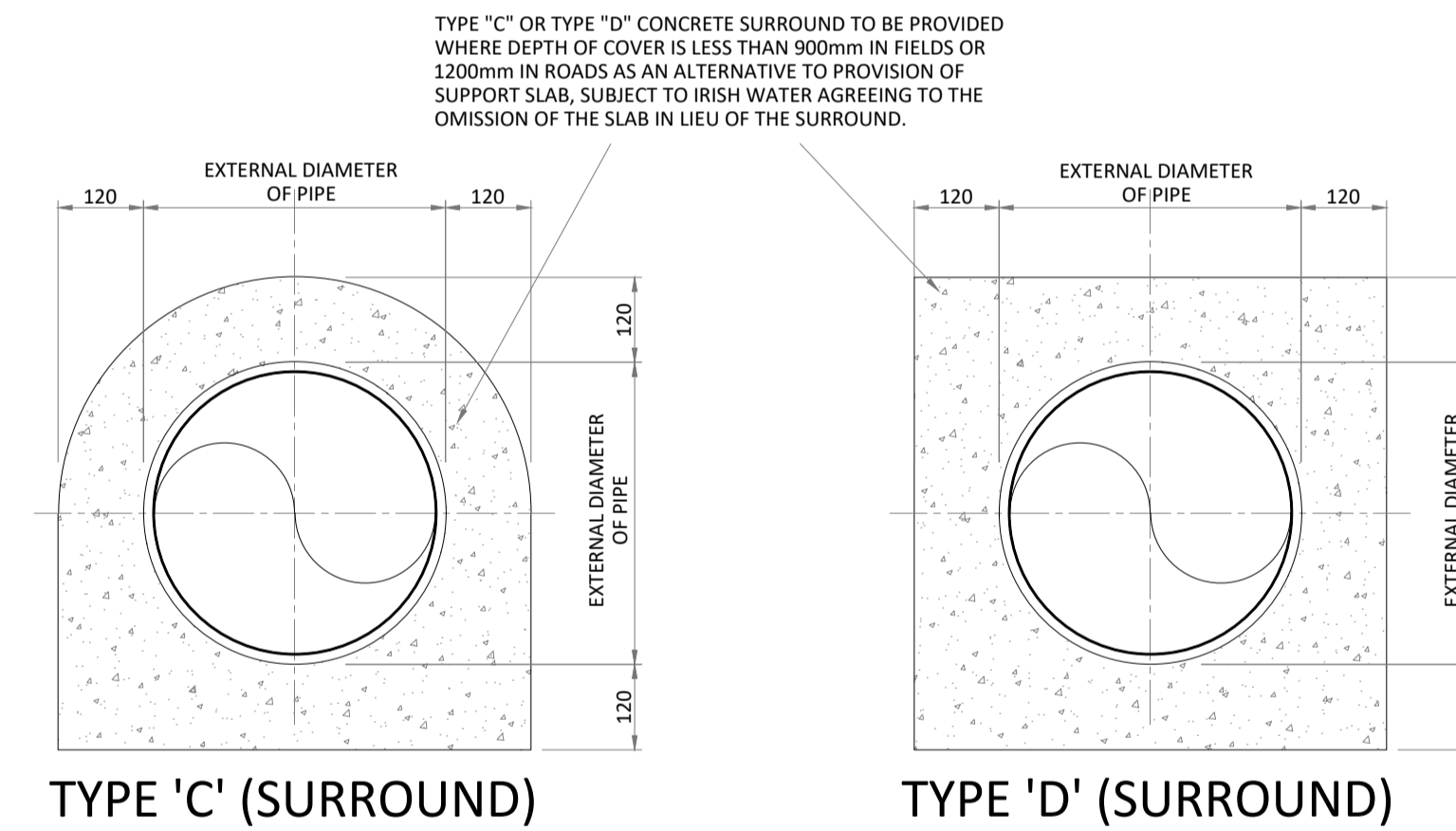
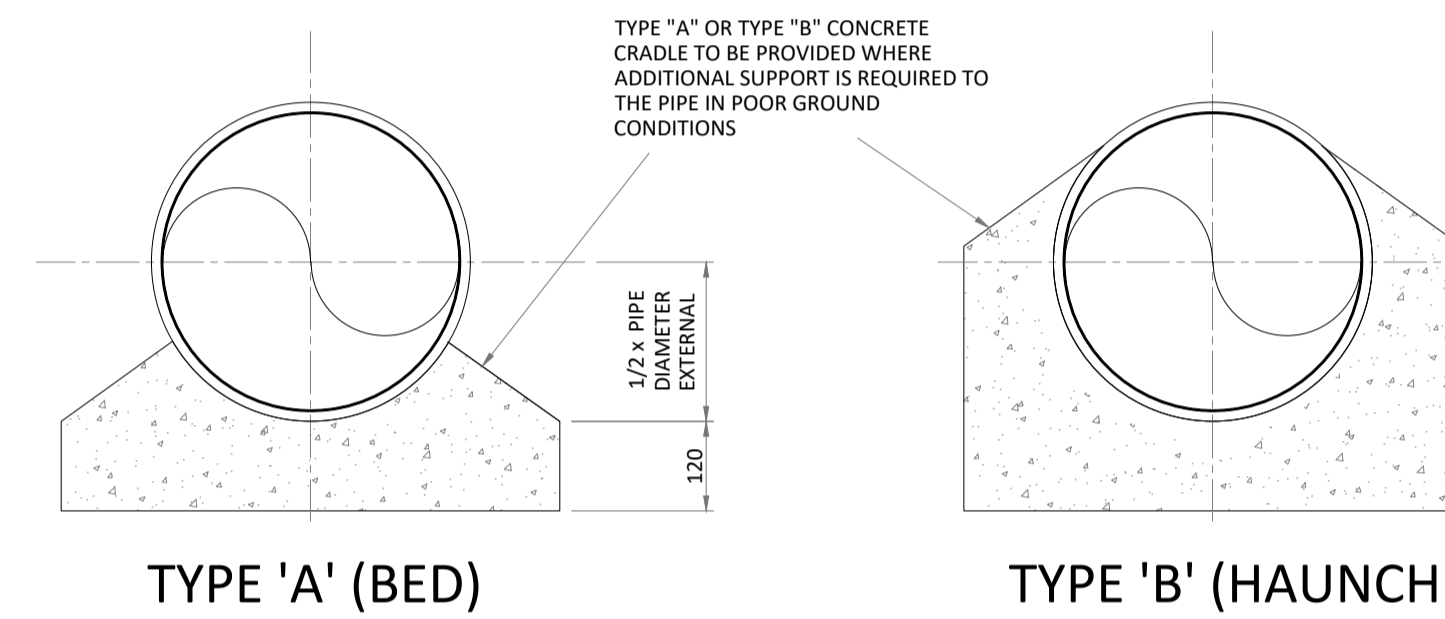

SPIGOT AND SOCKET JOINT

CONCRETE PROTECTION SLAB, BED, HAUNCH, AND SURROUND, TO WASTEWATER PIPES NOTES:

1. FOR ANY SLABBING WORKS TO BE CARRIED OUT WITHIN THE VICINITY OF THE PIPELINE, A METHOD STATEMENT IS TO BE SUBMITTED FOR REVIEW BY IRISH WATER.
 2. MARKER TAPE TO BE PLACED ABOVE THE SLAB AND ALONG THE DIRECTION OF THE PIPELINE.
 3. CONCRETE TO BE GRADE C30/35.
 4. MINIMUM COVER TO STEEL REINFORCEMENT = 40mm.
 5. SLABS TO BE DESIGNED FOR USE UNDER A HB25 LOAD IN ACCORDANCE WITH BS5400-2. DESIGN TO BE SUBMITTED TO IRISH WATER FOR ASSESSMENT PRIOR TO INSTALLATION.
 6. THE SOIL ON WHICH THE SLAB RESTS MUST HAVE A CBR OF 4% OR GREATER. WHERE THE CBR IS LESS THAN 4% THE MATERIAL SHALL BE REMOVED AND REPLACED WITH IMPORTED GRANULAR MATERIAL AS APPROVED BY IRISH WATER.
 7. IF DIRECTION OF PIPELINE AND DIRECTION OF TRAFFIC FLOW ARE PARALLEL, THE DIRECTION OF LAY OF THE SLAB IS TO BE AGAINST THE DIRECTION OF TRAFFIC FLOW.
-
8. IF PIPELINE PROTECTION SLAB IS TO BE USED SOLELY FOR IMPACT PROTECTION & OVERALL DEPTH OF COVER IS GREATER THAN 1.2m, THE DISTANCE BETWEEN UNDERSIDE OF SLAB & TOP OF PIPE MAY BE INCREASED AFTER CONSULTATION WITH IRISH WATER.
 9. ALL DIMENSIONS ARE IN MILLIMETRES (mm) UNLESS NOTED OTHERWISE.
 10. CONCRETE BED AND HAUNCHES MAY BE REQUIRED TO PROVIDE ADDITIONAL SUPPORT IN POOR GROUND CONDITIONS. PROPOSALS TO BE PROVIDED TO IRISH WATER WITH GEOTECHNICAL REPORT SUPPORTING THEIR USE.
 11. CONCRETE SURROUNDS SHALL HAVE A MINIMUM THICKNESS OF 150mm WITH AN ABSOLUTE MINIMUM DEPTH OF COVER ABOVE THE EXTERNAL CROWN OF THE PIPE OF 750mm.
 12. ALL CONCRETE TO BE IN ACCORDANCE WITH IS EN 206 AND TO BE GRADE C16/20 TO IS EN206.
 13. THE HAUNCHES AND SURROUNDS TO BE FORMED USING FORM WORK TO PROVIDE A ROUGH CAST FINISH.
 14. EXPANSION JOINTS IN THE CONCRETE SHALL BE PROVIDED AT ALL PIPE JOINTS TO ALLOW FOR PIPE FLEXIBILITY, COMPRESSIBLE FILLER BOARD TO BE IN ACCORDANCE WITH BS EN 622-1 AND BS EN 622-4, AND TO BE 18mm THICK.
 15. POLYETHYLENE AND UPVC PIPES SHALL BE WRAPPED IN PLASTIC SHEETING HAVING A COMPOSITION IN ACCORDANCE WITH BS 6076 BEFORE BEING CAST INTO CONCRETE.
 16. BITUMINOUS MATERIAL SHALL NOT BE PUT IN CONTACT WITH PE OR PVC PIPES.

TENDER DRAWING
NOT FOR CONSTRUCTION
THIS DRAWING HAS BEEN ISSUED FOR INFORMATION PURPOSES ONLY AND MUST NOT BE USED FOR CONSTRUCTION UNDER ANY CIRCUMSTANCES

SLIGO COUNTY COUNCIL

2nd Floor, Technology House, Galway Technology Park, Parkmore, Galway.

TEL +353 (0)91 771360

e: galway@ocsc.ie
w: www.ocsc.ie

Dublin | London | Belfast | Galway | Cork | Birmingham

OCSC O'CONNOR | SUTTON | CRONIN
Multidisciplinary Consulting Engineers

Client: SLIGO COUNTY COUNCIL
Project: ASH LANE GROUP HOUSING

Title: SURFACE AND WASTEWATER STANDARD DETAILS SHEET 4 OF 5

| Code | Originator | Zone | Level | Type | Role | Number | Status | Revision |
|------|------------|------|-------|------|------|--------|--------|----------|
| S603 | OCSC | XX | XX | DR | C | 0624 | D2 | P02 |

Date: FEB '23 Scale: A:N. @ A1 Drn by: AD Chkd by: TD Aprvd by:

ATTENUATION TANK 7m WIDE x 14m LONG x 0.6m DEEP (95% VOIDS)
(TOTAL STORAGE 55m³ 100 YEAR + 30% CC)

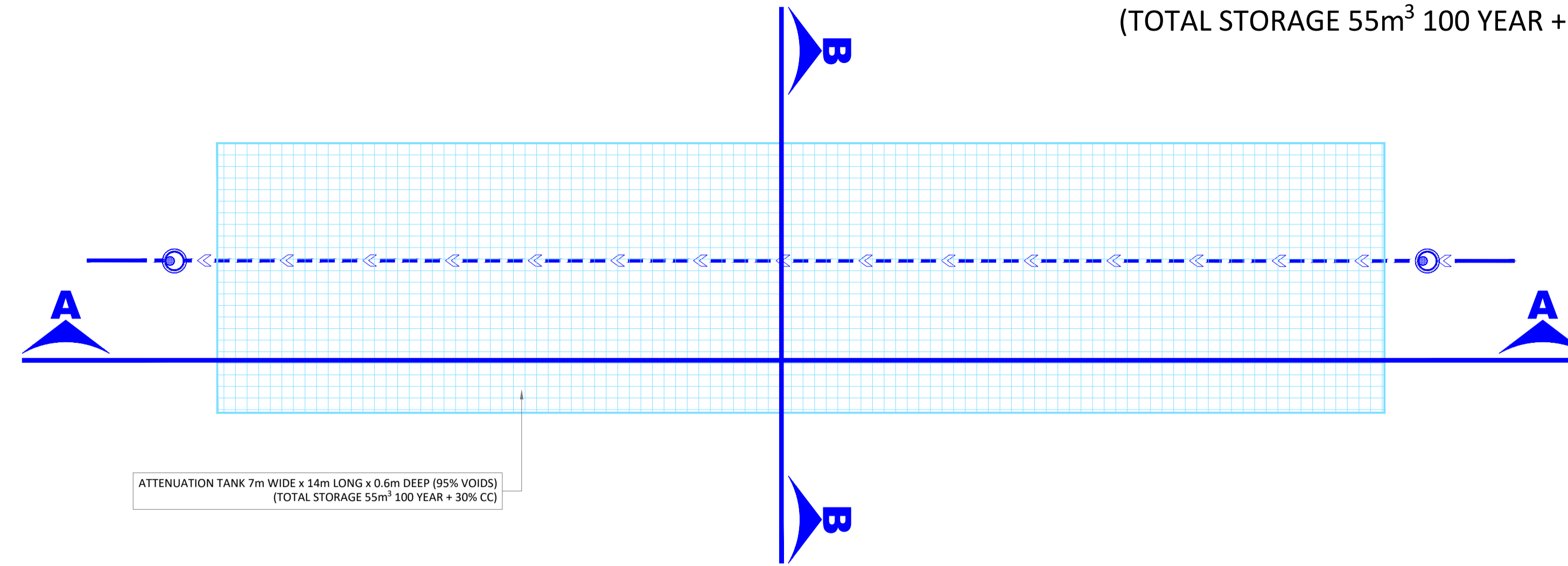

ATTENUATION TANK 7m WIDE x 14m LONG x 0.6m DEEP (95% VOIDS)
(TOTAL STORAGE 55m³ 100 YEAR + 30% CC)

ATTENUATION TANK ONLINE - TYPICAL CROSS-SECTION
SCALE 1:50

ATTENUATION TANK 7m WIDE x 14m LONG
x 0.6m DEEP (95% VOIDS)
(TOTAL STORAGE 55m³ 100 YEAR + 30% CC)

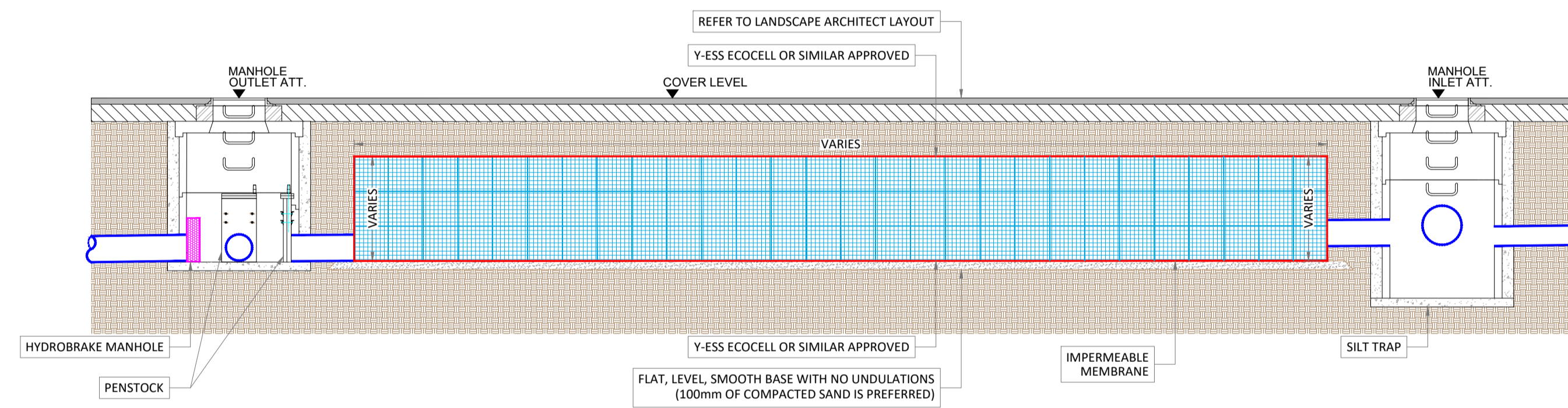

SECTION A-A
SCALE 1:50

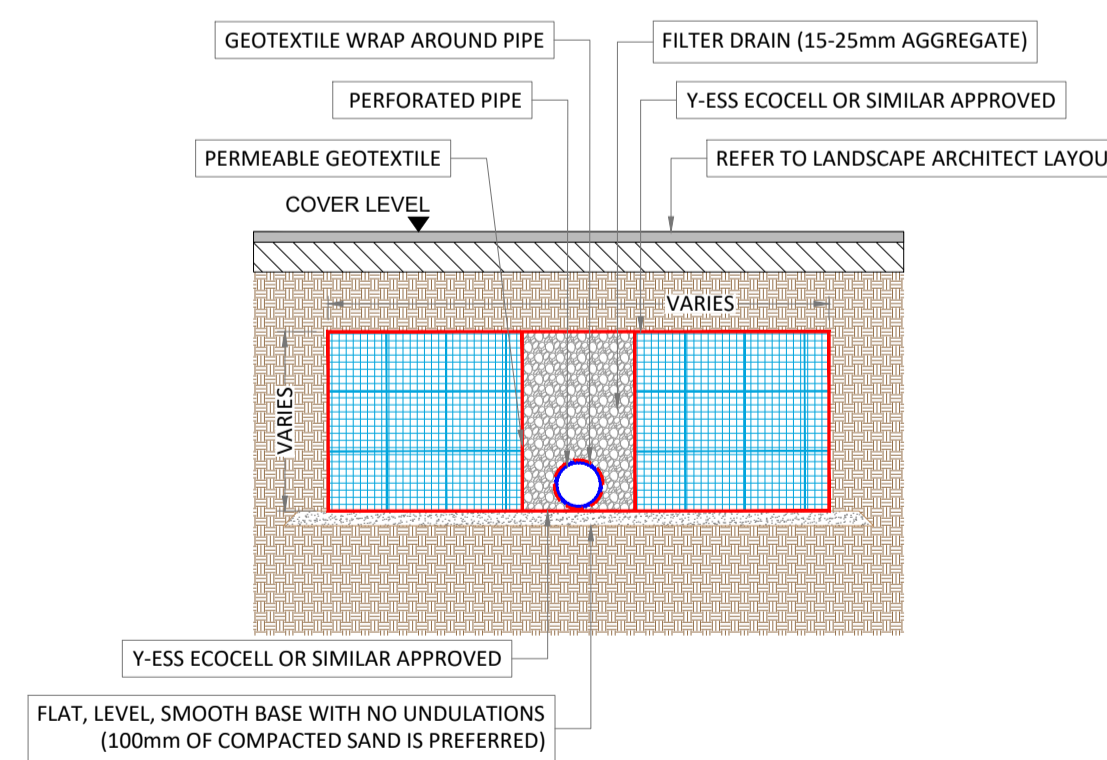

SECTION B-B
SCALE 1:50

TENDER DRAWING
NOT FOR CONSTRUCTION
THIS DRAWING HAS BEEN ISSUED FOR INFORMATION
PURPOSES ONLY AND MUST NOT BE USED
FOR CONSTRUCTION UNDER ANY CIRCUMSTANCES

- FOR SETTING OUT REFER TO ARCHITECT'S DRAWINGS.
- THIS DRAWING TO BE READ IN CONJUNCTION WITH ALL OTHER ARCHITECTURAL AND ENGINEERING DRAWINGS AND ALL OTHER RELEVANT DRAWINGS AND SPECIFICATIONS.
- DO NOT SCALE THIS DRAWING. USE FIGURED DIMENSIONS ONLY.
- NO PART OF THIS DOCUMENT MAY BE REPRODUCED OR TRANSMITTED IN ANY FORM OR STORED IN ANY RETRIEVAL SYSTEM OF ANY NATURE WITHOUT THE WRITTEN PERMISSION OF O'CONNOR SUTTON CRONIN AS COPYRIGHT HOLDER EXCEPT AS AGREED FOR USE ON THE PROJECT FOR WHICH THE DOCUMENT WAS ORIGINALLY ISSUED.

| Rev No. | Date | Revision Note | Drn by | Chkd by |
|---------|----------|-------------------|--------|---------|
| P01 | 16.02.23 | FOR INFORMATION | TD | TOD |
| P02 | 16.08.23 | ISSUED FOR TENDER | AD | TD |

| Rev No. | Date | Revision Note | Drn by | Chkd by |
|---------|------|---------------|--------|---------|
| | | | | |
| | | | | |



2nd Floor, Technology House,
Galway Technology Park,
Parkmore,
Galway.

TEL +353 (0)91 771360
e: galway@ocsc.ie
w: www.ocsc.ie



Dublin | London | Belfast | Galway | Cork | Birmingham

Client: SLIGO COUNTY COUNCIL
Project: ASH LANE GROUP HOUSING

Title: SURFACE AND WASTEWATER STANDARD DETAILS
SHEET 5 OF 5

| Code | Originator | Zone | Level | Type | Role | Number | Status | Revision |
|------|------------|------|-------|------|------|--------|--------|----------|
| S603 | OCSC | XX | XX | DR | C | 0625 | D2 | P02 |

Date: FEB '23 Scale: A.N. @ A1 Drn by: TD Chkd by: TOD Aprvd by:

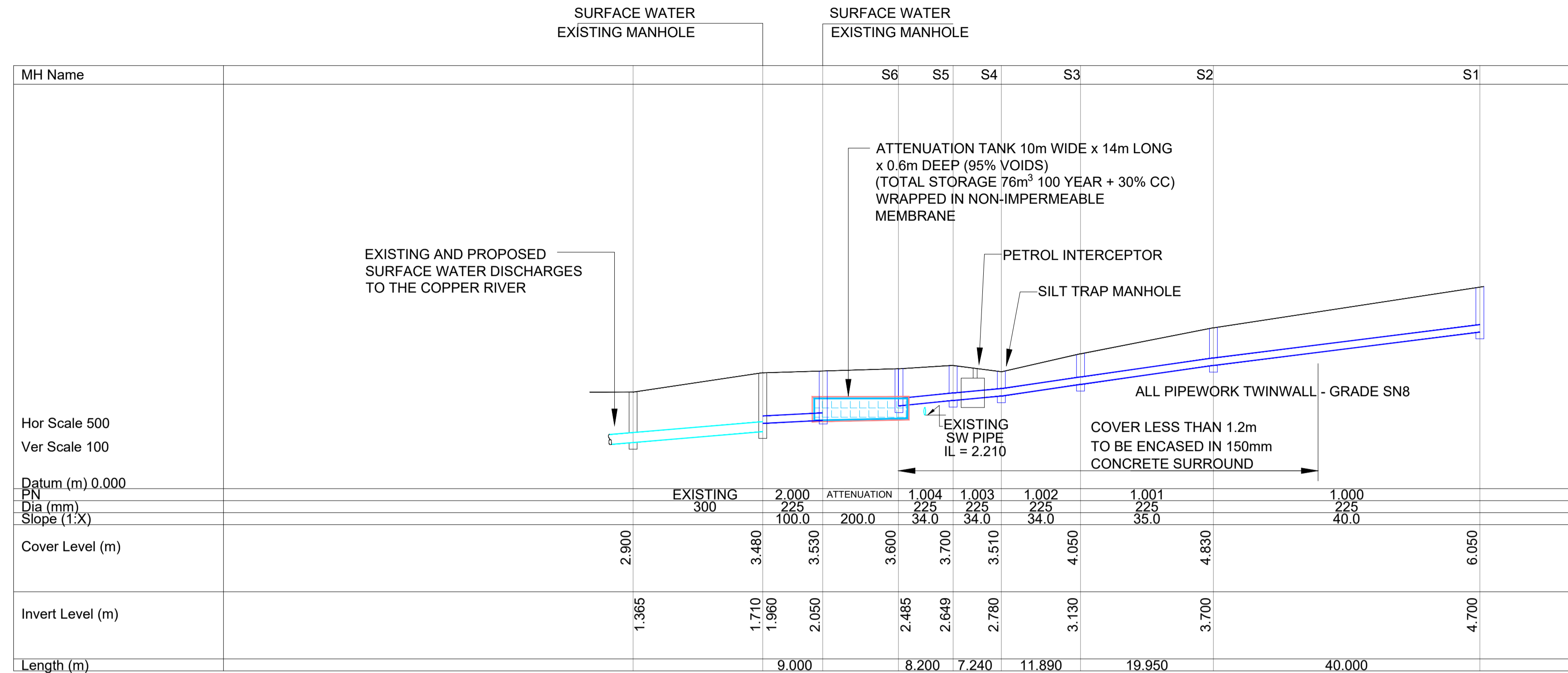

STORM WATER NETWORK 1
LONGITUDINAL ELEVATION S1 TO EXISTING
 SCALE 1:500 HOR , 1:100 VER

NOTES
 ALL DRAINAGE INFRASTRUCTURE TO BE INSTALLED IN ACCORDANCE WITH GDS5 AND GREATER DUBLIN REGION CODE OF PRACTICE

REFERENCE NOTE
 REFER TO DWG. NO. S603-OCSC-XX-DR-C-0620 FOR PROPOSED DRAINAGE LAYOUT

TENDER DRAWING
NOT FOR CONSTRUCTION
 THIS DRAWING HAS BEEN ISSUED FOR INFORMATION PURPOSES ONLY AND MUST NOT BE USED FOR CONSTRUCTION UNDER ANY CIRCUMSTANCES

- THIS DRAWING TO BE READ IN CONJUNCTION WITH ALL OTHER RELEVANT DESIGN TEAM DRAWINGS AND SPECIFICATIONS.
- FOR SETTING OUT REFER TO ARCHITECT'S DRAWINGS. DO NOT SCALE THIS DRAWING. USE FIGURED DIMENSIONS ONLY.
- NO PART OF THIS DOCUMENT MAY BE REPRODUCED OR TRANSMITTED IN ANY FORM OR STORED IN ANY RETRIEVAL SYSTEM OF ANY NATURE WITHOUT THE WRITTEN PERMISSION OF O'CONNOR SUTTON CRONIN AS COPYRIGHT HOLDER EXCEPT AS AGREED FOR USE ON THE PROJECT FOR WHICH THE DOCUMENT WAS ORIGINALLY ISSUED.

| Rev No. | Date | Revision Note | Drn by | Chkd by |
|---------|----------|-------------------|--------|---------|
| P01 | 24.06.23 | FOR INFORMATION | AD | TD |
| P02 | 16.08.23 | ISSUED FOR TENDER | AD | TD |

| Rev No. | Date | Revision Note | Drn by | Chkd by |
|---------|------|---------------|--------|---------|
| | | | | |
| | | | | |
| | | | | |
| | | | | |



OCSC
 O'CONNOR SUTTON CRONIN
 MULTIDISCIPLINARY CONSULTING ENGINEERS
 Civil / Structural / Environmental / Mechanical / Electrical / Sustainability
 Galway Office: Technology House, Galway Technology Park, Parkmore, Galway.
 Tel: +353 (0)91 771360 Web: www.ocsc.ie
 Dublin - London - Belfast - Galway - Cork - Birmingham

| | | | | | | | | | |
|----------|--|--------|------------|---------|------|----------|--------|-----------|--|
| Client: | SLIGO COUNTY COUNCIL | | | | | | | | |
| Project: | ASH LANE GROUP HOUSING GLENVIEW PARK ASH LANE SLIGO | | | | | | | | |
| Title: | SURFACE WATER LONGITUDINAL ELEVATIONS | | | | | | | | |
| Code | Originator | Zone | Level | Type | Role | Number | Status | Revision | |
| S603 | OCSC | XX | XX | DR | C | 0626 | D2 | P02 | |
| Date: | JUNE '23 | Scale: | @ A1: A.N. | Drn by: | AD | Chkd by: | TD | Aprvd by: | |

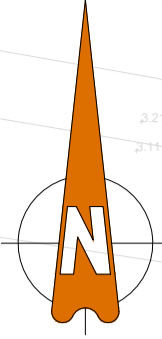

ALL MANHOLE AND ACCESS CHAMBER / AJ's COVERS TO BE CLASS D400 IN TRAFFICKED AREAS, B125 ELSEWHERE.

ALL PIPE WORK WITH LESS THAN 1200mm COVER TO BE ENCASED IN 100mm CONCRETE SURROUND

ALL NEW FOUL WATER PIPES TO BE GRADE SN8

LEGEND

| FOUL DRAINAGE NETWORK | |
|-----------------------|--|
| | EXISTING FOUL DRAINAGE PIPES TO BE RETAINED |
| | EXISTING FOUL DRAINAGE MANHOLES TO BE RETAINED |
| | PROPOSED FOUL DRAINAGE ACCESS CHAMBERS AND ENCASED IN 100m CONCRETE SURROUND |
| | PROPOSED 100mm DIA uPVC FOUL DRAINAGE PIPES GRADE SN8 WHERE COVER IS LESS THAN 1.2m IN TRAFFICKED AREAS PIPES ARE TO BE ENCASED IN 100mm CONCRETE SURROUND |
| | 100mm SOIL VENT PIPE |
| | BACK INLET GULLY TRAP TO SPECIALIST DETAIL ENCASED IN 100mm CONCRETE SURROUND |
| | 100mm Ø FOUL WATER POP UP PIPES ENCASED IN 100mm CONCRETE SURROUND |

NOTES

- ALL NOTED LEVELS ARE TO ORDNANCE DATUM, MALIN HEAD.
- REFER TO ARCHITECT'S LAYOUT FOR ALL SET-OUT INFORMATION.
- REFER TO ARCHITECT / LANDSCAPE ARCHITECT'S DESIGN DRAWINGS FOR DETAILS OF PROPOSED SURFACE FINISHES AND LANDSCAPING.
- ALL SURFACE WATER DRAINAGE IS TO BE INSTALLED IN ACCORDANCE WITH THE GREATER DUBLIN REGION CODE OF PRACTICE FOR DRAINAGE WORKS, THE BUILDING REGULATIONS PART H AND THE SITE DEVELOPMENT SPECIFICATION.
- ALL WASTEWATER DRAINAGE IS TO BE INSTALLED IN ACCORDANCE WITH THE IRISH WATER CODE OF PRACTICE FOR WASTEWATER INFRASTRUCTURE, THE BUILDING REGULATIONS PART H AND THE SITE DEVELOPMENT SPECIFICATION.
- ALL DRAINAGE COVER LEVELS ARE TO BE COORDINATED WITH THE PROPOSED ROAD DESIGN LEVELS AND ARCHITECT DESIGN FINISH DETAILS.
- ALL CONNECTIONS TO NEW DRAINAGE NETWORKS ARE TO BE MADE AT AN ANGLE OF 90° OR IN THE DIRECTION OF FLOW.
- THE CONTRACTOR IS TO VERIFY INVERT LEVEL AT PROPOSED CONNECTION TO EXISTING SEWERS, PRIOR TO ANY OTHER WORKS BEING CARRIED OUT, AND MAKE ANY DISCREPANCIES KNOWN TO THE ENGINEER.
- THE CONTRACTOR IS RESPONSIBLE FOR CONFIRMATION OF PRESENCE ALL EXISTING UTILITIES, IF ANY, ALONG ROUTE OF PROPOSED DRAINAGE NETWORKS - BY INTRUSIVE INVESTIGATION OR EQUAL.
- EXISTING PUBLIC SEWER TO BE JET CLEANED AND CCTV SURVEYED PRIOR TO, AND AFTER PROPOSED CONNECTIONS FROM NEW NETWORK.
- ALL NEW DRAINAGE INFRASTRUCTURE TO BE JET CLEANED AND CCTV SURVEYED, WITH ANY NOTED DEFECTS REMEDIATED, ON COMPLETION OF WORKS, TO THE SATISFACTION OF THE LOCAL AUTHORITY.
- REFER TO ARCHITECTS DRAWINGS FOR DETAILS OF PRIVATE DRAINAGE AND LANDSCAPE ARCHITECT'S PROPOSED FINISH LEVELS.
- ALL COVER LEVELS ARE TO BE COORDINATED WITH ROAD DESIGN LEVELS AND LANDSCAPE ARCHITECT'S PROPOSED FINISH LEVELS.
- THE INTERNAL BUILDING DRAINAGE TO BE COORDINATED WITH ARCHITECT'S LAYOUT.
- ALL MANHOLES / ACCESS CHAMBER COVERS SUBJECT TO TRAFFIC LOADINGS TO BE CLASS D400 OTHERWISE B125 GRADE

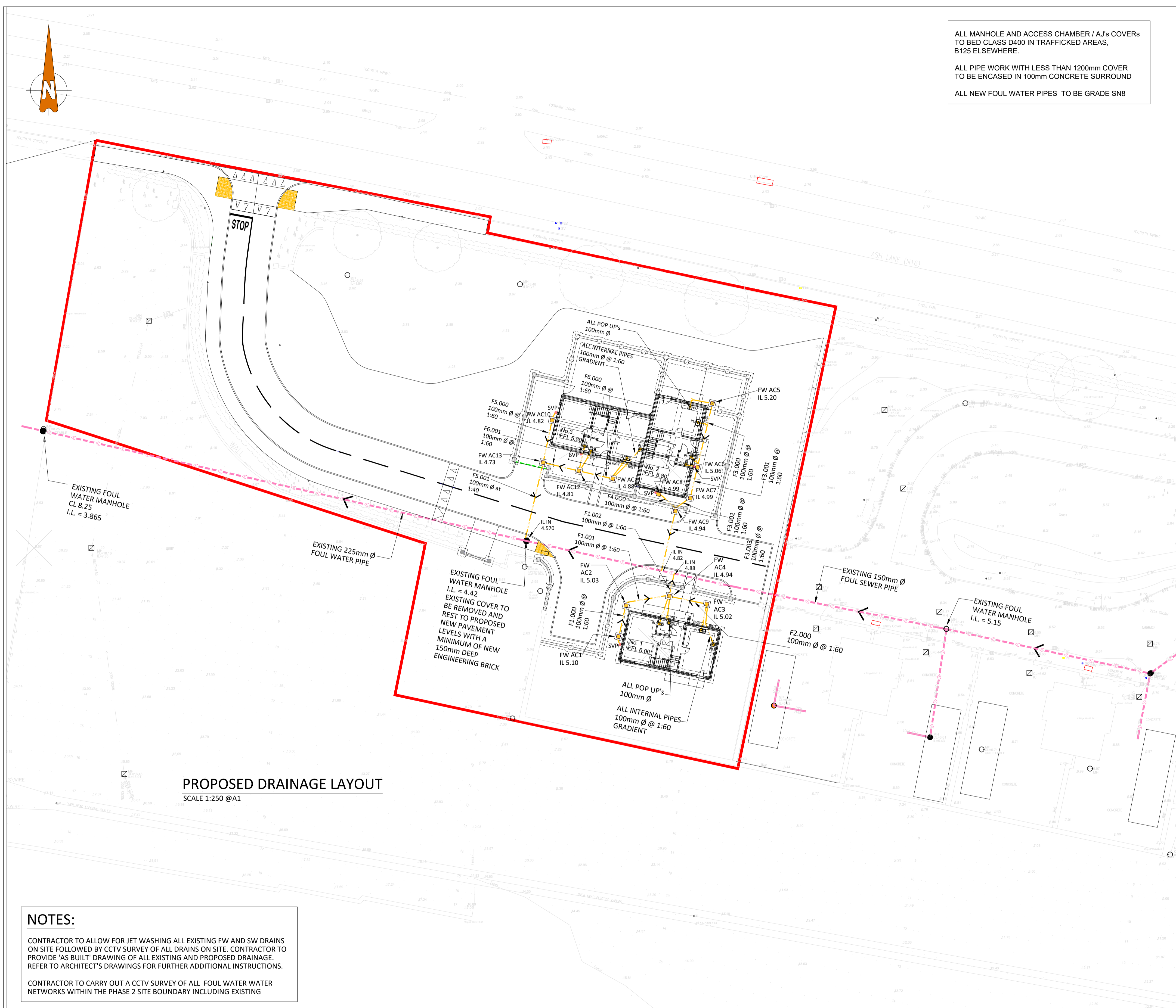

PROPOSED DRAINAGE LAYOUT
SCALE 1:250 @A1

NOTES:

CONTRACTOR TO ALLOW FOR JET WASHING ALL EXISTING FW AND SW DRAINS ON SITE FOLLOWED BY CCTV SURVEY OF ALL DRAINS ON SITE. CONTRACTOR TO PROVIDE 'AS BUILT' DRAWING OF ALL EXISTING AND PROPOSED DRAINAGE. REFER TO ARCHITECT'S DRAWINGS FOR FURTHER ADDITIONAL INSTRUCTIONS.

CONTRACTOR TO CARRY OUT A CCTV SURVEY OF ALL FOUL WATER WATER NETWORKS WITHIN THE PHASE 2 SITE BOUNDARY INCLUDING EXISTING

TENDER DRAWING
NOT FOR CONSTRUCTION
THIS DRAWING HAS BEEN ISSUED FOR INFORMATION PURPOSES ONLY AND MUST NOT BE USED FOR CONSTRUCTION UNDER ANY CIRCUMSTANCES

- FOR SETTING OUT REFER TO ARCHITECT'S DRAWINGS.
- THIS DRAWING TO BE READ IN CONJUNCTION WITH ALL OTHER ARCHITECTURAL AND ENGINEERING DRAWINGS AND ALL OTHER RELEVANT DRAWINGS AND SPECIFICATIONS.
- DO NOT SCALE THIS DRAWING. USE FIGURED DIMENSIONS ONLY.
- NO PART OF THIS DOCUMENT MAY BE REPRODUCED OR TRANSMITTED IN ANY FORM OR STORED IN ANY RETRIEVAL SYSTEM OF ANY NATURE WITHOUT THE WRITTEN PERMISSION OF O'CONNOR SUTTON CRONIN AS COPYRIGHT HOLDER EXCEPT AS AGREED FOR USE ON THE PROJECT FOR WHICH THE DOCUMENT WAS ORIGINALLY ISSUED.

| Rev No. | Date | Revision Note | Drn by | Chkd by |
|---------|----------|-------------------|--------|---------|
| P01 | 05.08.23 | FOR INFORMATION | AD | TD |
| P02 | 16.08.23 | ISSUED FOR TENDER | AD | TD |

| Rev No. | Date | Revision Note | Drn by | Chkd by |
|---------|------|---------------|--------|---------|
| | | | | |



2nd Floor, Technology House,
Galway Technology Park,
Parkmore,
Galway.

TEL +353 (0)91 771360

e: galway@ocsc.ie
w: www.ocsc.ie

Dublin | London | Belfast | Galway | Cork | Birmingham

Client: SLIGO COUNTY COUNCIL
Project: ASH LANE GROUP HOUSING
Title: PROPOSED FOUL DRAINAGE LAYOUT

Code | Originator | Zone | Level | Type | Role | Number | Status | Revision
S603 - OCSC - XX - XX - DR - C - 0627 | D2 | P02
Date: AUG '23 Scale: 1:250 @ A1 Drn by: AD Chkd by: TD Aprvd by:

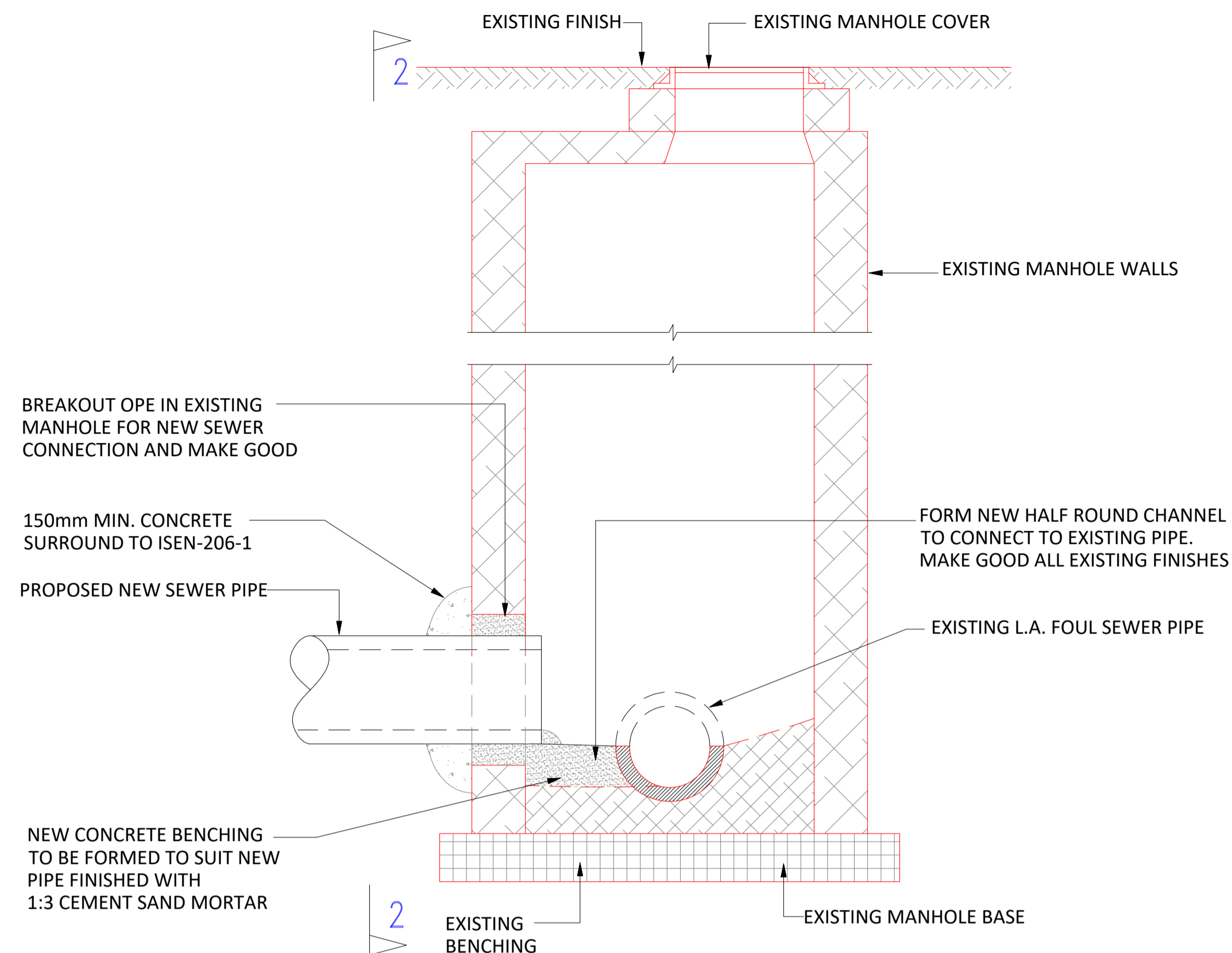

SECTION 1 - 1
SCALE 1:20

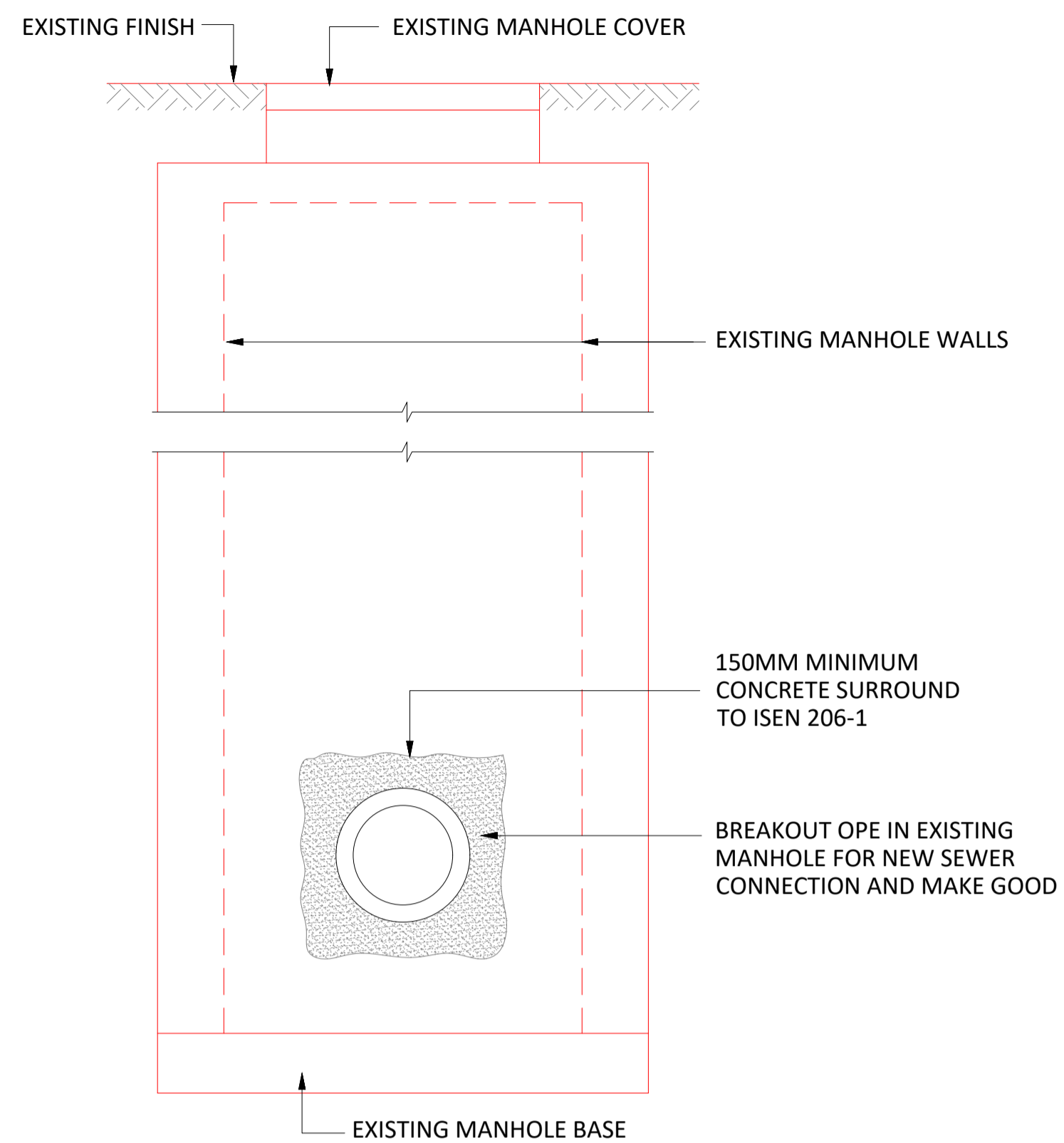

SECTION 2 - 2
SCALE 1:20

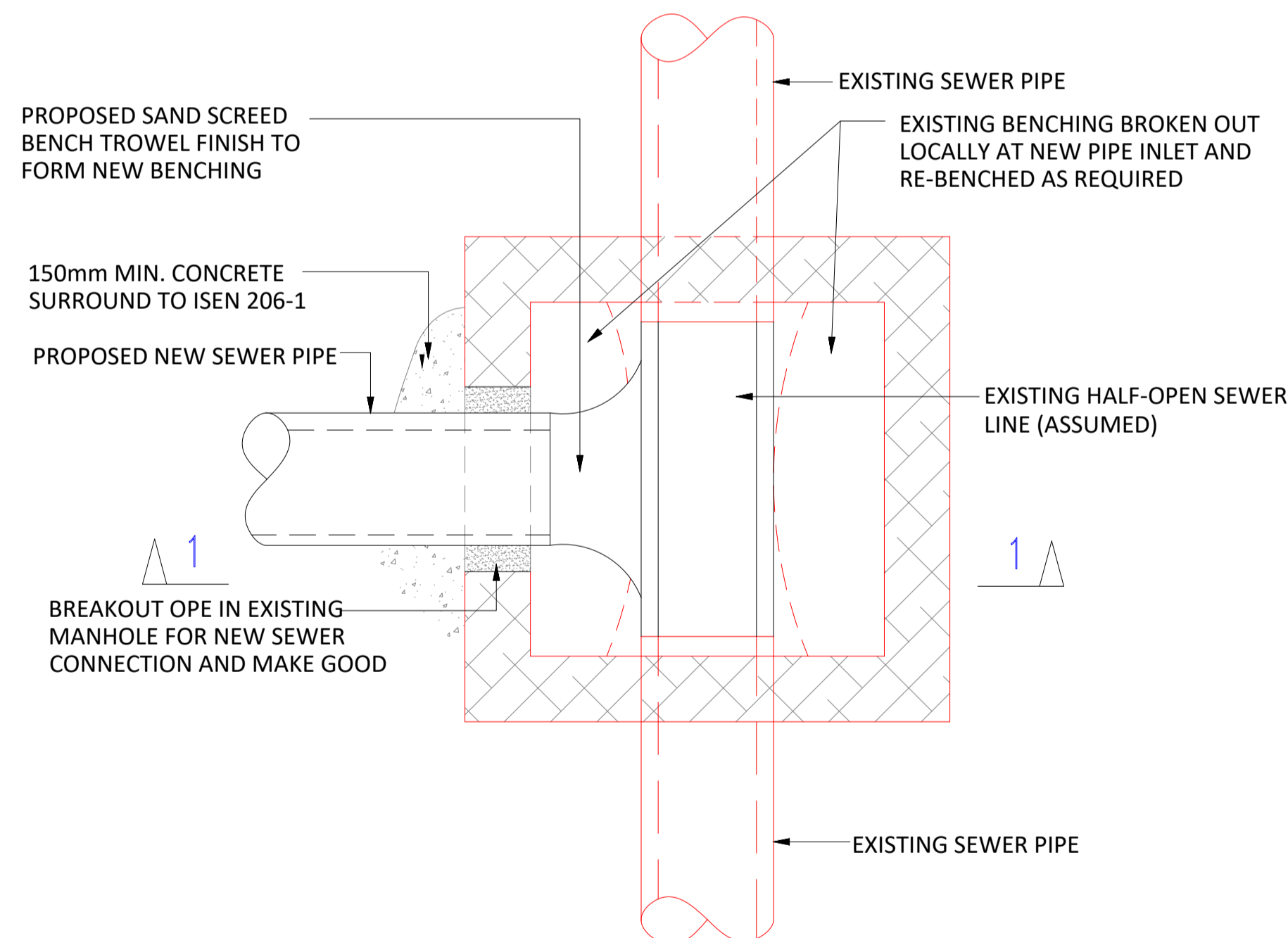

PLAN
SCALE 1:20

TYPICAL CONNECTION TO EXISTING MANHOLE
SCALE 1:20

NOTE:
CONTRACTORS TO ALLOW FOR FULL REINSTATEMENT TO AREAS OF GROUND EFFECTED BY THE WORKS. IN GENERAL, WHERE MAKING GOOD IS REQUIRED, IT SHOULD BE OF AN EQUAL STANDARD TO THE GROUND PRIOR TO THE COMMENCEMENT OF THE WORKS. REFER TO OCSC SITE DEVELOPMENT SPECIFICATION FOR FURTHER DETAILS.

NOTE:
ALL PIPE WORK TO BE LAID IN STRICT ACCORDANCE WITH MANUFACTURER'S WRITTEN INSTRUCTION

- NOTES:**
- DO NOT SCALE FROM THIS DRAWING USE STATED DIMENSIONS ONLY. IF IN DOUBT CONSULT THE ENGINEER.
 - LEVELS REFER TO O.S. DATUM MALIN HEAD.
 - PRECAST MANHOLE RINGS, COVER SLABS AND REDUCING SLABS SHALL COMPLY WITH I.S. 420:1989.
 - PRECAST MANHOLE RINGS, COVER SLABS AND REDUCING SLABS SHALL BE INSTALLED COMPLETE WITH TYPE 2 RUBBER GASKETS AND JOINTING RINGS WHICH COMPLY WITH B.S. 2494.
 - CONCRETE TO MANHOLE BASES AND SURROUNDS SHALL BE A MINIMUM OF 150MM THICK (TO ISEN 206-1 AND CONTAIN ONE LAYER OF BS REF A142 REINFORCEMENT MESH).
 - BLINDING SHALL BE A MINIMUM THICKNESS OF 100mm.
 - SAND CEMENT RENDER 25MM THICK SHALL BE APPLIED TO THE BENCHING AND CHANNEL WITH A STEEL TROWEL FINISH.
 - LADDER RUNGS SHALL BE P.V.C. COATED STEEL. FOR MANHOLES WITH A DEPTH TO INVERT GREATER THEN 4.0M USE GRADE 316 STAINLESS STEEL LADDERS.
 - DROP PIPE WORK SHALL BE SIZED IN ACCORDANCE WITH TABLE NO. 1. WHERE THE CONNECTION < 1.0M ABOVE INVERT USE RAMP CONNECTION, WHERE CONNECTION IS > 1.0M ABOVE INVERT USE DROP CONNECTION.
 - LOCKABLE MANHOLE COVERS AND FRAMES SHALL COMPLY WITH I.S. E.N. 124, AND SHALL BE CLASS D400 WITH A CIRCULAR OPENING OF 600MM MINIMUM AND A SQUARE FRAME.
 - SUITABLE SHORT LENGTHS OF PIPE OR ROCKER PIPES SHALL BE INSTALLED TO PROVIDE A FLEXIBLE JOINT WITHIN 1000MM OF THE OUTER FACE OF THE MANHOLE ON ALL SEWERS AND BRANCHES.
 - SEMI ENGINEERING BRICK SHALL BE GRADE 47N/MM2.
 - FOR ALL INLETS, OUTLETS AND BRANCHES MATCH CROWN LEVELS UNLESS INDICATED OTHERWISE ELSEWHERE.
 - THIS DRAWING SHALL BE READ IN CONJUNCTION WITH THE OCSC SPECIFICATION.

- NOTES:**
- WHERE ROCK IS MET IN TRENCHES IT SHALL BE EXCAVATED AND TRIMMED TO PRESCRIBED LEVEL OF UNDERSIDE OF GRANULAR BED TO PIPELINE.
 - GRANULAR MATERIAL 14-5mm NOMINAL SIZE GRADED AGGREGATE (TO COMPLY WITH TABLE 1 OF BS) TO BE USED FOR BEDDING, HAUNCHING AND SURROUND.
 - CONCRETE FOR BEDDING, HAUNCHING AND SURROUND WHERE SPECIFIED TO ISEN 206-1
 - WHERE RIGID PIPES WITH FLEXIBLE JOINTS ARE USED WITH CONCRETE BEDS FOR SEWERS AND WATERMANS, VERTICAL MOVEMENT JOINTS WILL BE PROVIDED IN THE BED AT MAX INTERVALS OF 5.0m AND ALIGNED WITH FACE OF PIPE SOCKET. JOINTS TO BE 12mm WIDE AND FILLED WITH COMPRESSIBLE FILLER BOARD OR SIMILAR IN THE CONCRETE BED AND SURROUND.
 - SURFACE WATER PIPES SHALL BE SURROUNDED BY 150mm THICKNESS OF CONCRETE IF COVER TO THE PIPES IS LESS THAN 1.2m IN ROAD AND DRIVEWAYS AND 0.9m IN OPEN SPACES AND PATHS NOT NEAR CARRIAGEWAYS.
 - ALL CONCRETE TO BE AS PER ISEN 206-1
 - WHERE FLEXIBLE PIPES ARE ENCASED IN CONCRETE, THEY SHALL BE WRAPPED IN VISQUEEN 1000 GAUGE.
 - WHERE COVER FOR FLEXIBLE PIPES IS LESS THAN 1200mm IN ROADS AND 900mm IN GARDENS A PROTECTIVE CONCRETE RAFT MAY BE USED PROVIDED A CUSHION OF PROTECTIVE FILL IS LAID BETWEEN THE CROWN OF THE PIPE AND THE UNDERSIDE OF THE RAFT SLAB - REFER TO SUPPLIER DETAILS.
 - WHERE DRAINS ARE WITHIN 2.4m OF ROAD RESERVATION & PAVED THEY SHALL BE BACKFILLED IN IMPORTED GRANULAR FILL (ALL GRANULAR FILL MATERIAL TO COMPLY SR 21, LAID AND COMPACTED IN 225mm LAYERS).
 - ALL DRAINAGE PIPE RUNS TO BE LAID IN STRAIGHT LINE, NO DEVIATION OR BENDS ARE PERMITTED. ROUTES TO BE AGREED ON SITE IN ADVANCE OF EXCAVATION ENSURING ALL OBSTRUCTIONS IN THE FORM OF EXTENDED MANHOLE CHAMBERS OR OTHER SERVICES TO BE AGREED

TENDER DRAWING
NOT FOR CONSTRUCTION
THIS DRAWING HAS BEEN ISSUED FOR INFORMATION PURPOSES ONLY AND MUST NOT BE USED FOR CONSTRUCTION UNDER ANY CIRCUMSTANCES

- FOR SETTING OUT REFER TO ARCHITECT'S DRAWINGS.
- THIS DRAWING TO BE READ IN CONJUNCTION WITH ALL OTHER ARCHITECTURAL AND ENGINEERING DRAWINGS AND ALL OTHER RELEVANT DRAWINGS AND SPECIFICATIONS.
- DO NOT SCALE THIS DRAWING. USE FIGURED DIMENSIONS ONLY.
- NO PART OF THIS DOCUMENT MAY BE REPRODUCED OR TRANSMITTED IN ANY FORM OR STORED IN ANY RETRIEVAL SYSTEM OF ANY NATURE WITHOUT THE WRITTEN PERMISSION OF O'CONNOR SUTTON CRONIN AS COPYRIGHT HOLDER EXCEPT AS AGREED FOR USE ON THE PROJECT FOR WHICH THE DOCUMENT WAS ORIGINALLY ISSUED.

| Rev No. | Date | Revision Note | Drn by | Chkd by |
|---------|----------|-------------------|--------|---------|
| P01 | 16.08.23 | ISSUED FOR TENDER | AD | TD |

| Rev No. | Date | Revision Note | Drn by | Chkd by |
|---------|------|---------------|--------|---------|
| | | | | |



2nd Floor, Technology House,
Galway Technology Park,
Parkmore,
Galway.

TEL +353 (0)91 771360

e: galway@ocsc.ie
w: www.ocsc.ie

Dublin | London | Belfast | Galway | Cork | Birmingham



Client: **SLIGO COUNTY COUNCIL**
Project: **ASH LANE GROUP HOUSING**

Title: **CONNECTION OF NEW SEWERS TO EXISTING L.A. / IW MANHOLES**

| Code | Originator | Zone | Level | Type | Role | Number | Status | Revision |
|------|------------|------|-------|------|------|--------|--------|----------|
| S603 | OCSC | XX | XX | DR | C | 0628 | D2 | P01 |

Date: AUG '23 Scale: 1:20 @ A1 Drn by: AD Chkd by: TD Aprvd by:

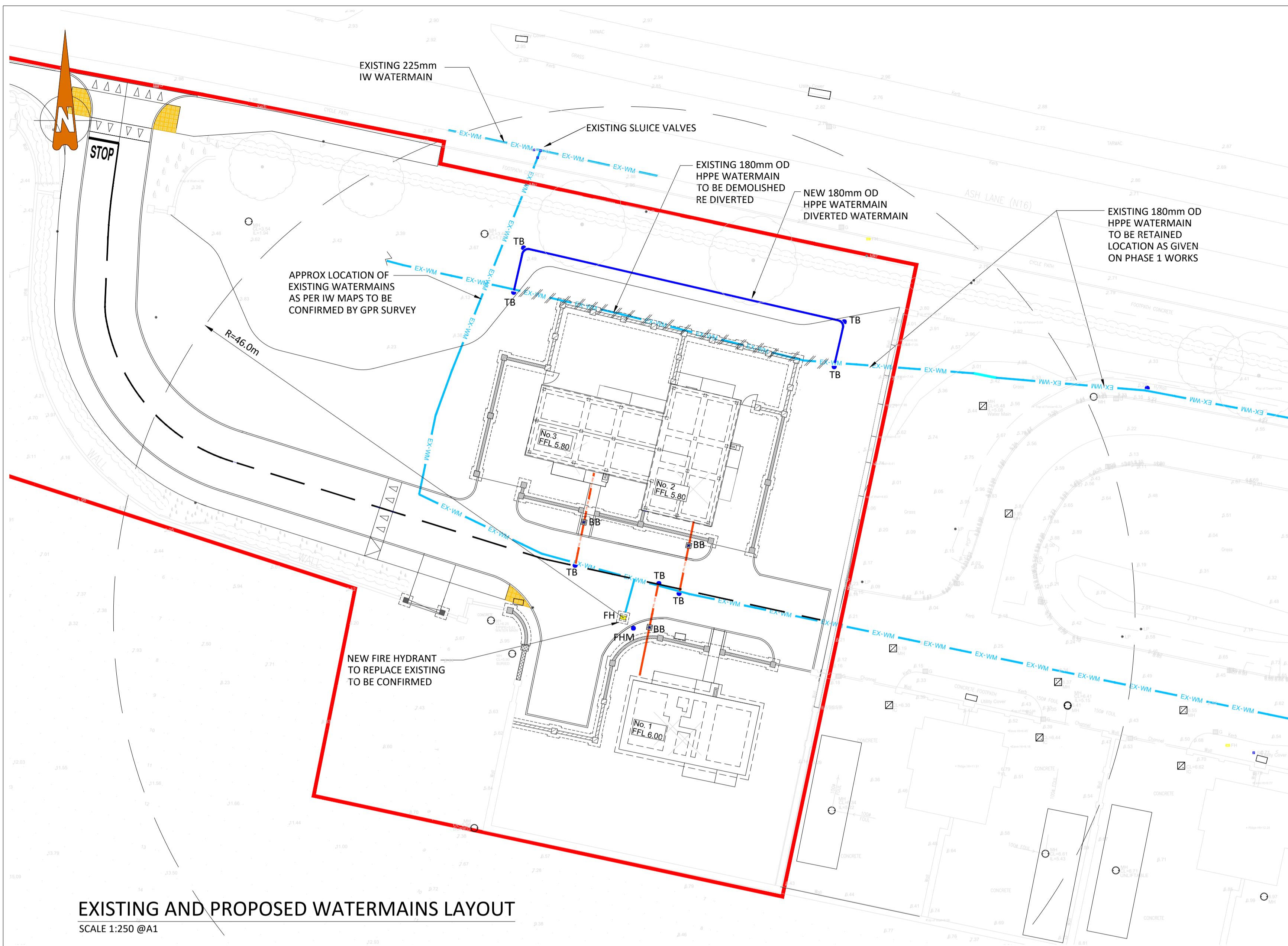

IRISH WATER NOTE:

ALL WORKS TO WATERMAINS TO COMPLY WITH THE FOLLOWING IRISH WATER DOCUMENTS:

- "CODE OF PRACTICE FOR WATER INFRASTRUCTURE - DOCUMENT NO. IW-CDS-5020-03." REV 02 JULY 2020
- "WATER INFRASTRUCTURE STANDARD DETAILS - DOCUMENT NO IW-CDS-5020-01." REV 04 JULY 2020

NOTE - THAT WHERE THERE ARE ANY DISCREPANCIES BETWEEN THE ABOVE DOCUMENTS, DOCUMENT NO. - IW-CDS-5020-01 WILL TAKE PRECEDENCE AS INSTRUCTED BY IRISH WATER.

NOTE: WHERE ANY CHAMBERS COVERS ARE LOCATED IN A GRASSED AREA THEY SHALL BE SURROUNDED BY 200mm ALL AROUND AND 100mm DEEP FORMED WITH C20/25 CONCRETE, 20mm AGGREGATE SIZE BEDDED IN CLAUSE 804 MATERIAL IN ACCORDANCE WITH IW SPECIFICATIONS. THE PLINTH SHALL INCORPORATE MILD STEEL REINFORCEMENT LINKS AND SHALL HAVE A BULL-NOSE FINISH AROUND ITS EXTERNAL PERIMETER AS PER SECTION 3.18 OF THE IRISH WATER CODE OF PRACTICE FOR WATER INFRASTRUCTURE.

MINIMUM SEPARATION NOTES:

THE MINIMUM HORIZONTAL DISTANCE BETWEEN ANY BUILDING AND THE NEAREST FACE OF THE WATER MAINS PIPE IS TO BE 3.0m MINIMUM FOR 150mm DIAMETER PIPE AS SHOWN ON IRISH WATER STANDARD DETAIL STD-W-11.

THE MINIMUM HORIZONTAL DISTANCE BETWEEN ANY BOUNDARY WALL AND THE NEAREST FACE OF THE WATER MAINS PIPE IS TO BE 1.0m MINIMUM FOR 150mm DIAMETER PIPE AS SHOWN ON IRISH WATER STANDARD DETAIL STD-W-11.

THE MINIMUM HORIZONTAL DISTANCE BETWEEN ANY KERB AND THE NEAREST FACE OF THE WATER MAINS PIPE IS TO BE 0.75m MINIMUM FOR 150mm DIAMETER PIPE AS SHOWN ON IRISH WATER STANDARD DETAIL STD-W-11.

REFER TO DETAIL 'A' WHERE IS AN EXTRACT FROM IRISH WATER STANDARD DETAIL STD-W-11.

THESE MINIMUM SEPARATION DISTANCES TO BE STRICTLY ADHERED TO.

WATERMAIN LEGEND:

| | |
|--|---|
| | EXISTING IW 150mm Ø + 180mm Ø WATERMAIN NETWORKS |
| | EXISTING 180mm Ø WATERMAIN TO BE DEMOLISHED |
| | PROPOSED 180mm Ø PE WATERMAIN (HDPE) - REFER TO SECTION 3.9 IW COP FOR WATER INFRASTRUCTURE |
| | PROPOSED BULK WATER METER - (IW STD-W-26) TBC |
| | PROPOSED FIRE HYDRANT - (IW STD-W-018) |
| | PROPOSED FIRE HYDRANT MARKER PLATE - (IW STD-W-27) |
| | PROPOSED SLUICE VALVE (IW STD-W-15) TBC |
| | PROPOSED IRISH WATER APPROVED BOUNDARY BOX AND HOUSE CONNECTION - (IW STD-W-03) |
| | PROPOSED SCOUR VALVE - (IW STD-W-30) TBC |
| | PROPOSED AIR CONTROL VALVE - (IW STD-W-22) TBC |
| | PROPOSED 25mm Ø HOUSING UNIT SUPPLY |
| | PROPOSED THRUST BLOCKS - (IW STD-W-028) |
| | DENOTES AREA OF COVERAGE FOR FIRE HYDRANT (46M IN ACCORDANCE WITH THE TECHNICAL GUIDANCE DOCUMENTS, PART B) |
| | CONNECTION POINTS TO EXISTING IW MAINS |
| MARKER POST AND PLATES FOR ALL VALVES, HYDRANTS MAINS PIPES TO BE PROVIDED THROUGHOUT IN ACCORDANCE WITH IRISH WATER STANDARD DETAILS - STD-W-27 | |
| | OFFLINE FIRE HYDRANT TBC |
| | BULK METER KIOSK |
| | WATERMAIN TELEMETRY KIOSK TO IW STD-W-36. (DUCTING TO IW STD-W-29) TBC |

NOTES:

- 1...ALL CHAMBERS & COVERS, PIPEWORK, BEDDING, SLUICE VALVES, HYDRANTS, AIR VALVES, SCOUR VALVES, CONNECTION DETAILS AND WATER METERS TO BE AS GIVEN IN THE IRISH WATER DOCUMENT - WATER INFRASTRUCTURE STANDARD DETAILS, CONNECTIONS AND DEVELOPER SERVICES.
- 2...ALL WATER PRESSURE TESTING TO BE IN ACCORDANCE WITH IRISH WATER SPECIFICATIONS. RESULTS INCLUDING METHODS CARRIED OUT AND PHOTOGRAPHIC EVIDENCE TO BE SUBMITTED TO OCSC FOR APPROVAL.
- 3...ALL MAKING GOOD TO DISTURBED EXISTING ROADS & VERGE DURING THE WORKS TO BE CARRIED OUT IN ACCORDANCE WITH OCSC / TII SPECIFICATIONS. IN GENERAL, WHERE MAKING GOOD IS REQUIRED TO THE EXISTING SURFACES IT SHALL BE OF AN EQUAL STANDARD TO THE GROUND PRIOR TO COMMENCEMENT OF THE WORKS. PLEASE NOTE THAT IT IS A REQUIREMENT TO PROVIDE GOOD AND PROPER RE-INSTATEMENT TO ALL GROUND AFFECTED BY THE ASSOCIATED GROUND WORKS. CONTRACTORS ARE ADVISED THAT NO ADDITIONAL MONIES WILL BE PAID FOR SUB-STANDARD RE-INSTATEMENT. CONTRACTORS ARE TO ALLOW FOR SUITABLE IMPORTED FILL MATERIAL FOR BACKFILLING TRENCHES EXCAVATED AND MUST BE PROPERLY COMPACTED AND FINISHED (FINISH TO MATCH EXISTING PRIOR TO COMMENCEMENT OF THE WORKS) LEVEL WITH THE EXISTING FINISHED SURFACE LEFT WITHOUT TRIP HAZARDS ETC.
- 4...ALL PIPEWORK, FITTINGS AND BOXES TO BE CE CERTIFIED AND ALL DOCUMENTATION TO BE SUBMITTED TO OCSC FOR APPROVAL PRIOR TO COMMENCEMENT OF THE WORKS.
- 5...THE INFORMATION RELATING TO THE LOCATION OF THE EXISTING SERVICES AS SHOWN ON THIS DRAWINGS HAVE BEEN OBTAINED FROM ANOTHER SOURCE OCSC ACCEPTS NO RESPONSIBILITY AS TO THE ACCURACY OF THE INFORMATION RELATING TO EITHER TOPOGRAPHICAL SURVEY OR PRESENCE OF EXISTING SERVICES.

NO WATERMAIN IS TO BE PLACED WITHIN 1.0M OF BOUNDARY WALLS AND 3.0M WITHIN EXTERNAL WALLS OF IN ACCORDANCE WITH IRISH WATER STANDARD DETAIL - REF NO STD-W-11 & DETAIL 'A' BELOW

LANDSCAPING AND POSITIONING OF TREES SHOULD SATISFY THE RESTRICTIONS OUTLINED IN IW STANDARD DETAILS STD-W-12 & STD-W-12A

ALL TRENCH BACKFILL AND BEDDING TO BE IN ACCORDANCE WITH IW STANDARD DETAIL STD-W-13

EXISTING AND PROPOSED WATERMAINS LAYOUT
SCALE 1:250 @A1

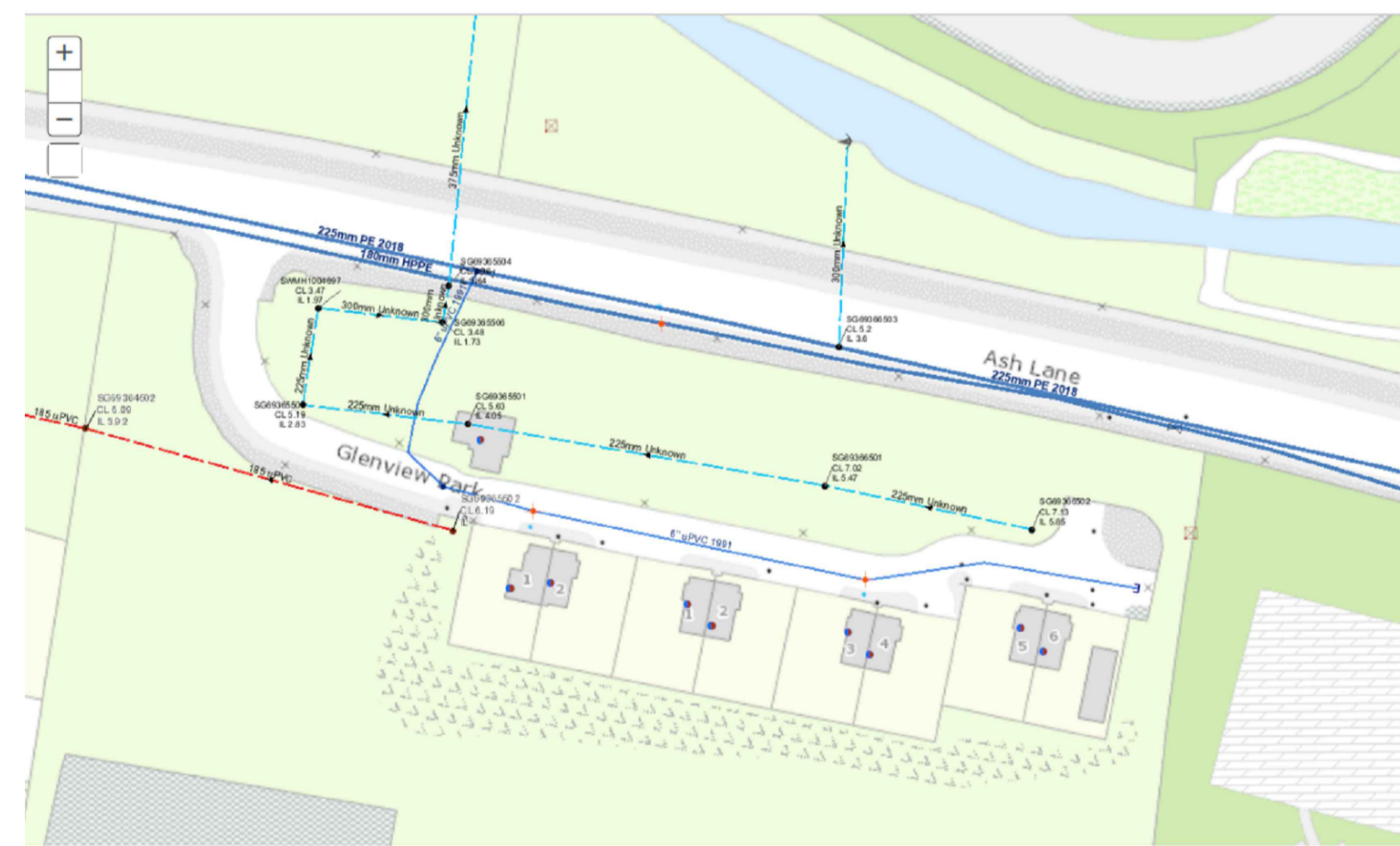

EXTRACT IW WATERMAINS LAYOUT
SCALE N.T.S.

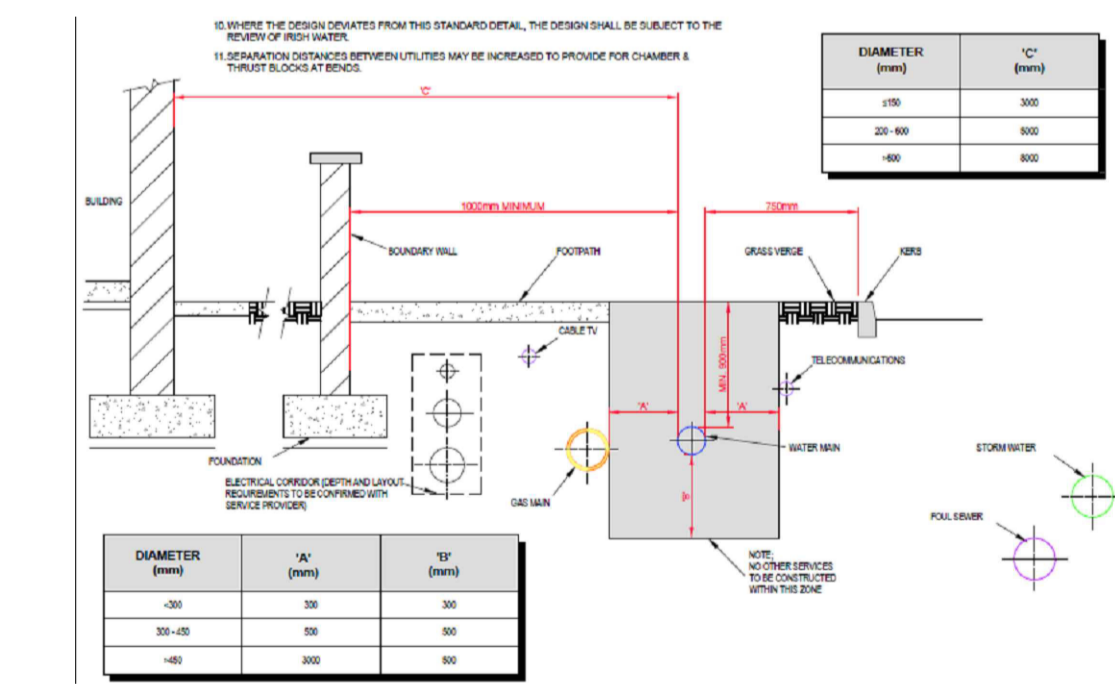

DETAIL 'A'
EXTRACT FROM IRISH WATER STANDARD DETAIL STD-W-11

TENDER DRAWING
NOT FOR CONSTRUCTION
THIS DRAWING HAS BEEN ISSUED FOR INFORMATION PURPOSES ONLY AND MUST NOT BE USED FOR CONSTRUCTION UNDER ANY CIRCUMSTANCES

- FOR SETTING OUT REFER TO ARCHITECT'S DRAWINGS.
- THIS DRAWING TO BE READ IN CONJUNCTION WITH ALL OTHER ARCHITECTURAL AND ENGINEERING DRAWINGS AND ALL OTHER RELEVANT DRAWINGS AND SPECIFICATIONS.
- DO NOT SCALE THIS DRAWING. USE FIGURED DIMENSIONS ONLY.
- NO PART OF THIS DOCUMENT MAY BE REPRODUCED OR TRANSMITTED IN ANY FORM OR STORED IN ANY RETRIEVAL SYSTEM OF ANY NATURE WITHOUT THE WRITTEN PERMISSION OF O'CONNOR SUTTON CRONIN AS COPYRIGHT HOLDER EXCEPT AS AGREED FOR USE ON THE PROJECT FOR WHICH THE DOCUMENT WAS ORIGINALLY ISSUED.

| Rev No. | Date | Revision Note | Drn by | Chkd by |
|---------|----------|--|--------|---------|
| P01 | 16.02.23 | FOR INFORMATION | TD | TOD |
| P02 | 02.03.23 | EXISTING WATERMAIN REVISED AS BUBBLED | TD | TOD |
| P03 | 24.06.23 | REDLINE BOUNDARY UPDATED | AD | TD |
| P04 | 02.08.23 | LAYOUT UPDATED AS PER REVISED ARCHITECT LAYOUT | AD | TD |
| P05 | 16.08.23 | ISSUED FOR TENDER | AD | TD |

| Rev No. | Date | Revision Note | Drn by | Chkd by |
|---------|------|---------------|--------|---------|
| | | | | |
| | | | | |
| | | | | |

SLIGO COUNTY COUNCIL

OCSC
O'CONNOR | SUTTON | CRONIN
Multidisciplinary Consulting Engineers

NSAI Certified

2nd Floor, Technology House, Galway Technology Park, Parkmore, Galway.

TEL +353 (0)91 771360

e: galway@ocsc.ie
w: www.ocsc.ie

Dublin | London | Belfast | Galway | Cork | Birmingham

Client: SLIGO COUNTY COUNCIL
Project: ASH LANE GROUP HOUSING
Title: EXISTING AND PROPOSED WATERMAINS

| Code | Originator | Zone | Level | Type | Role | Number | Status | Revision |
|------|------------|------|-------|------|------|--------|--------|----------|
| S603 | OCSC | XX | XX | DR | C | 0630 | D2 | P05 |

Date: FEB '23 Scale: 1:250 @ A1 Drn by: AD Chkd by: TD Aprvd by:

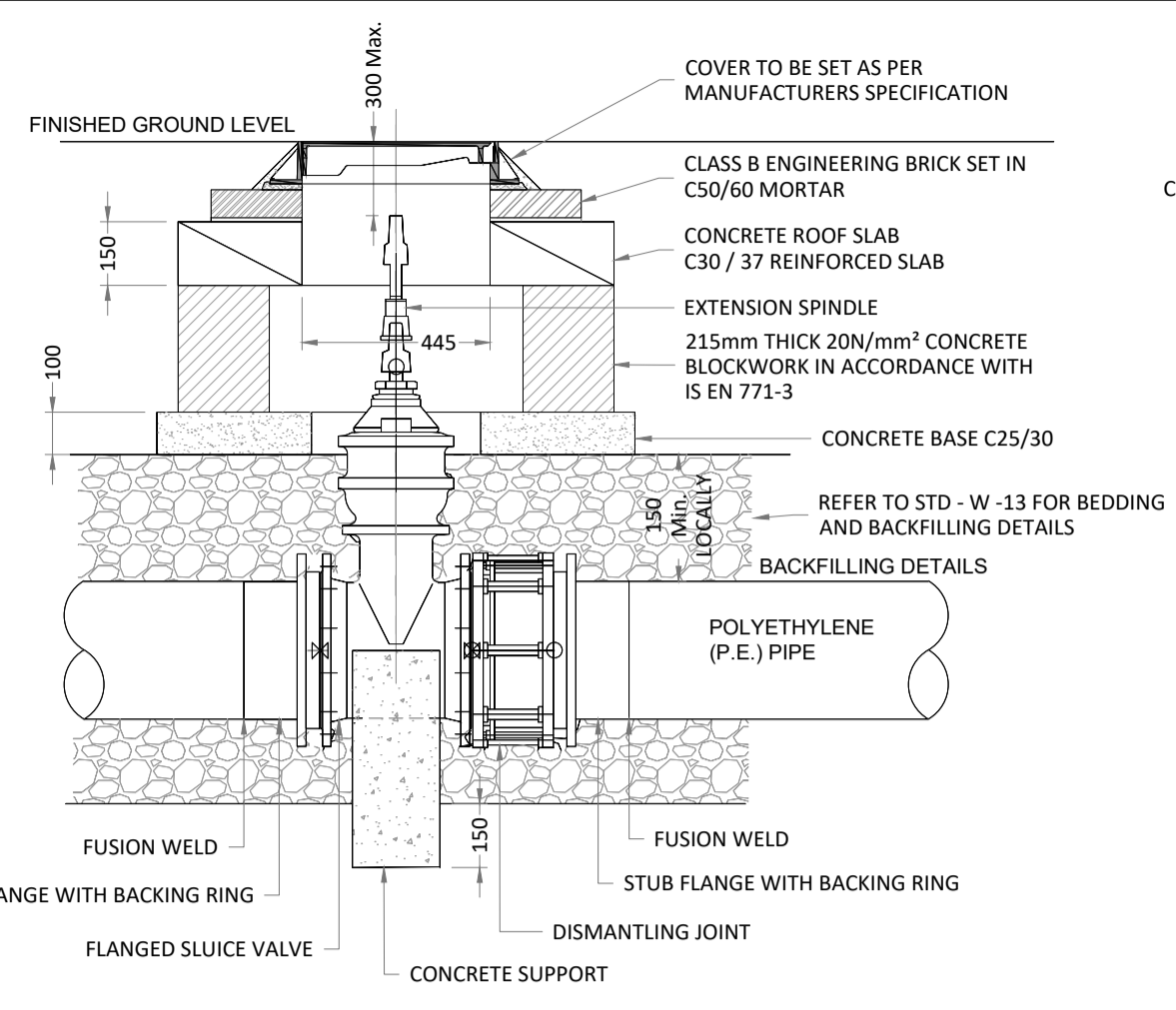

SECTION

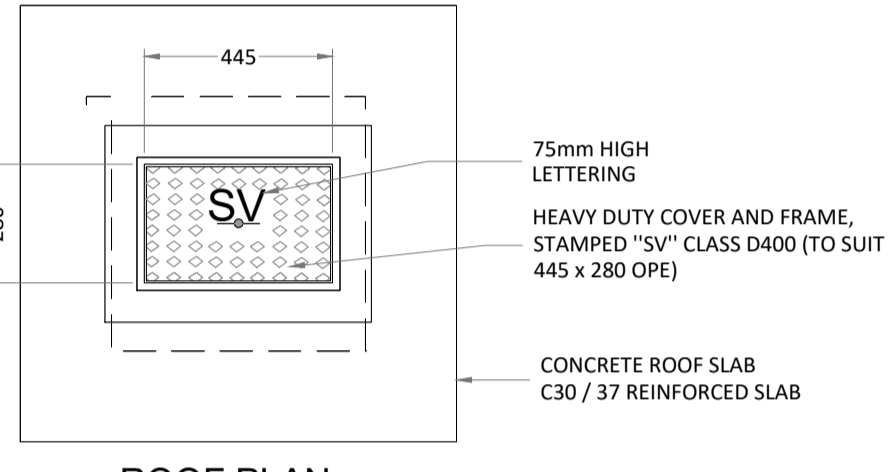

ROOF PLAN

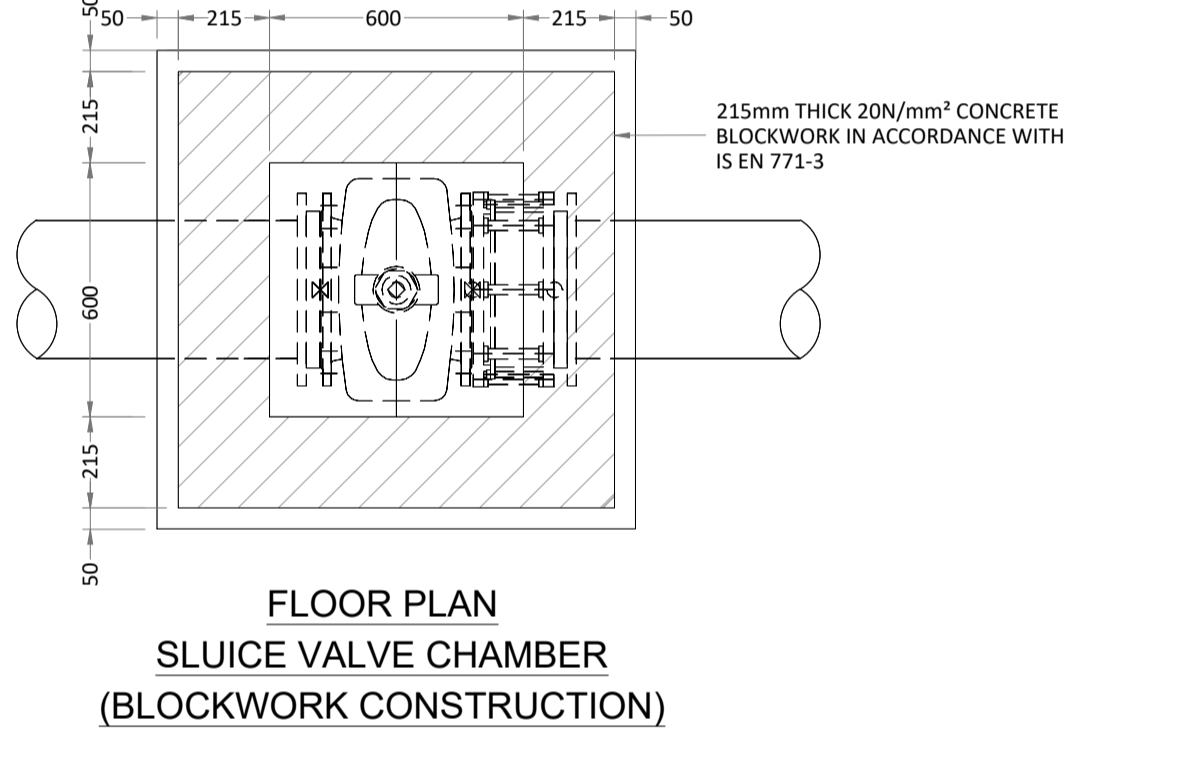

FLOOR PLAN
SLUISE VALVE CHAMBER
(BLOCKWORK CONSTRUCTION)

SLUISE VALVE FOR POLYETHYLENE (P.E.) PIPE (< 350mm DIA.)

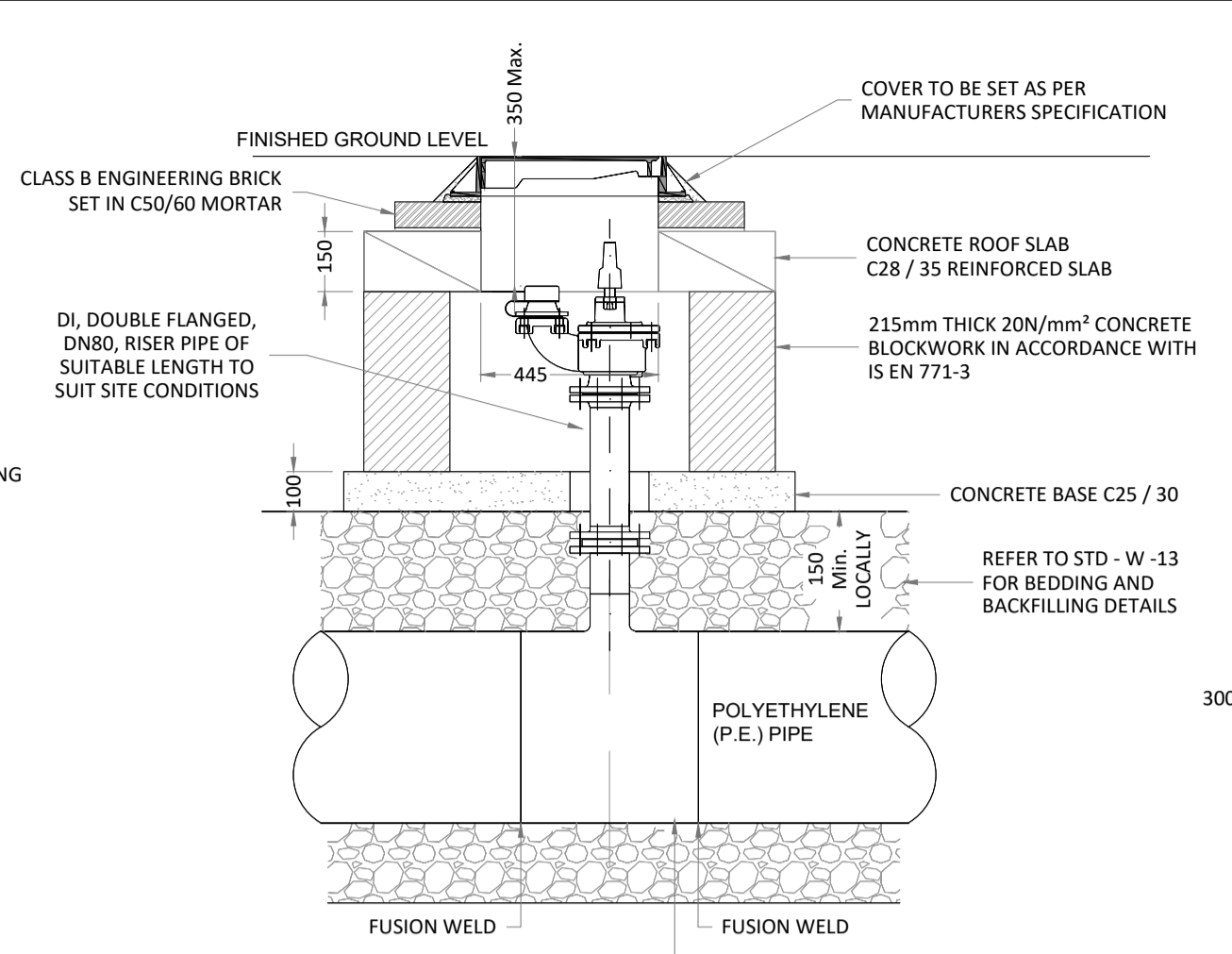

SECTION

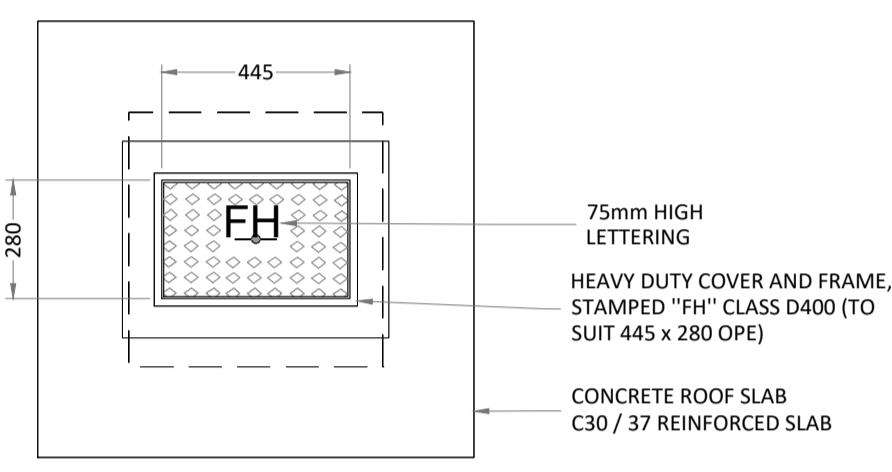

ROOF PLAN

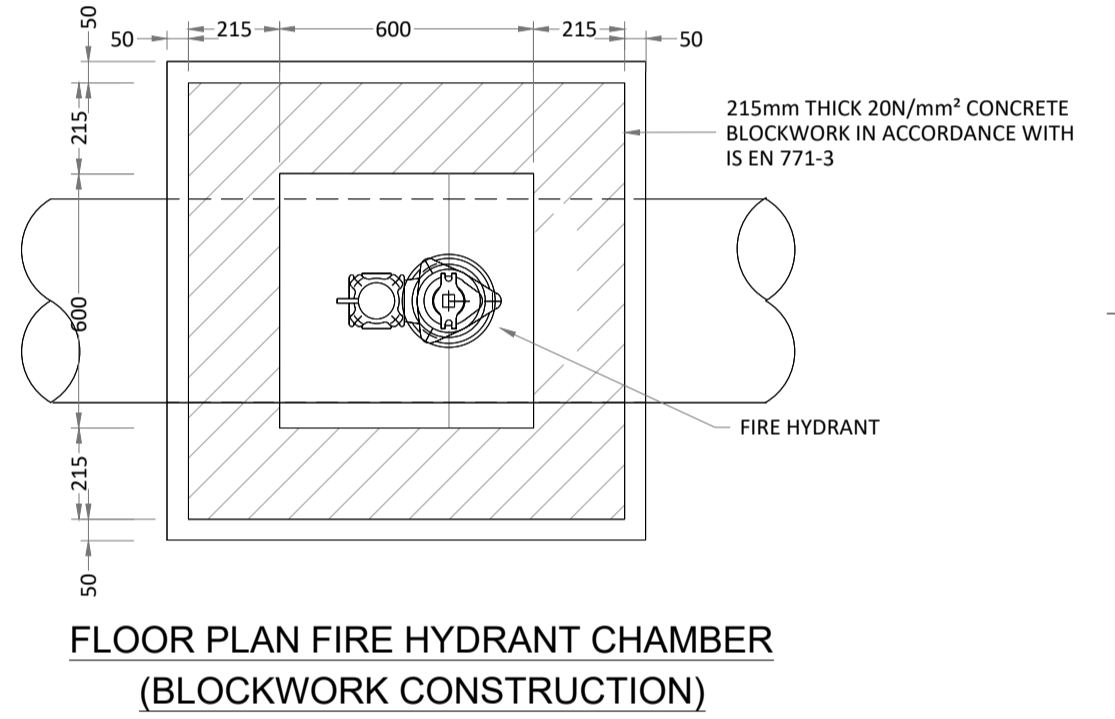

FLOOR PLAN FIRE HYDRANT CHAMBER
(BLOCKWORK CONSTRUCTION)

ON - LINE HYDRANT FOR POLYETHYLENE (P.E.) PIPE

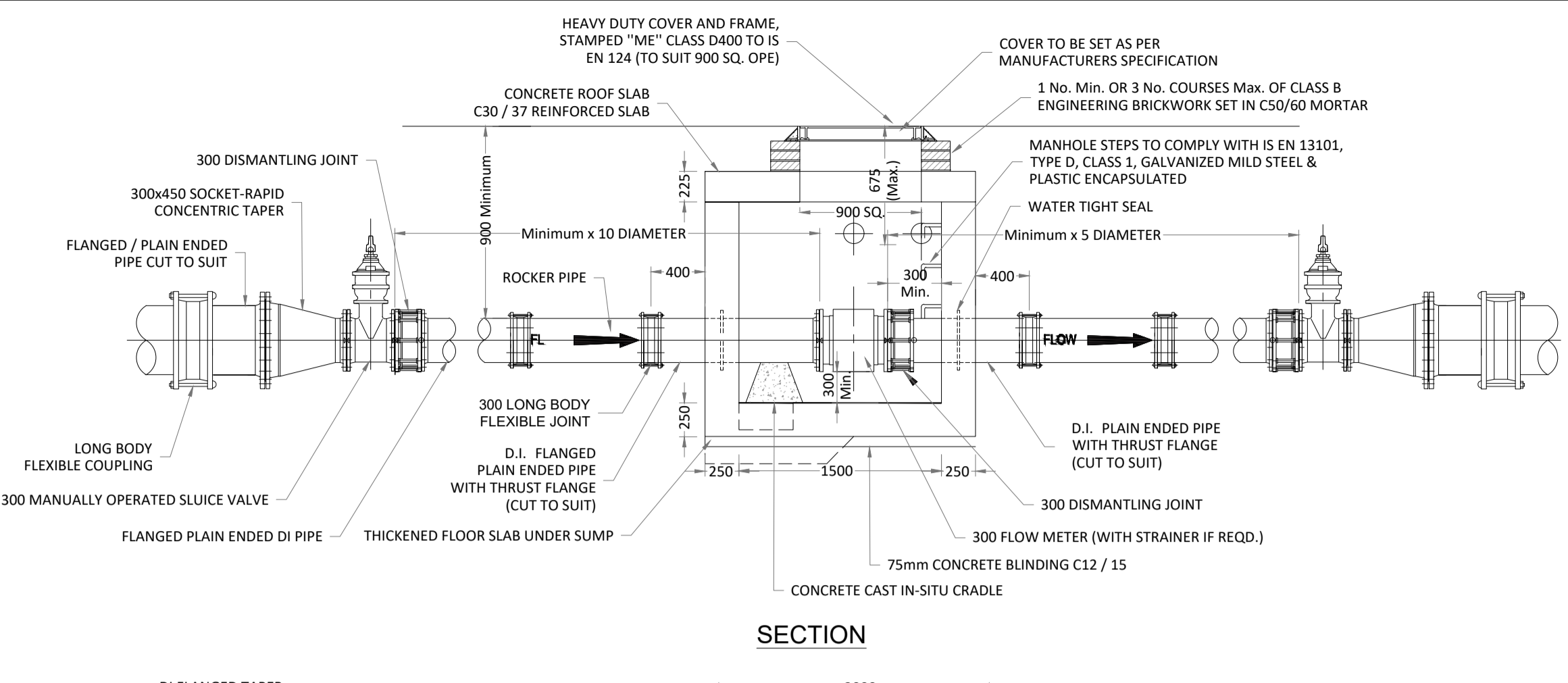

SECTION

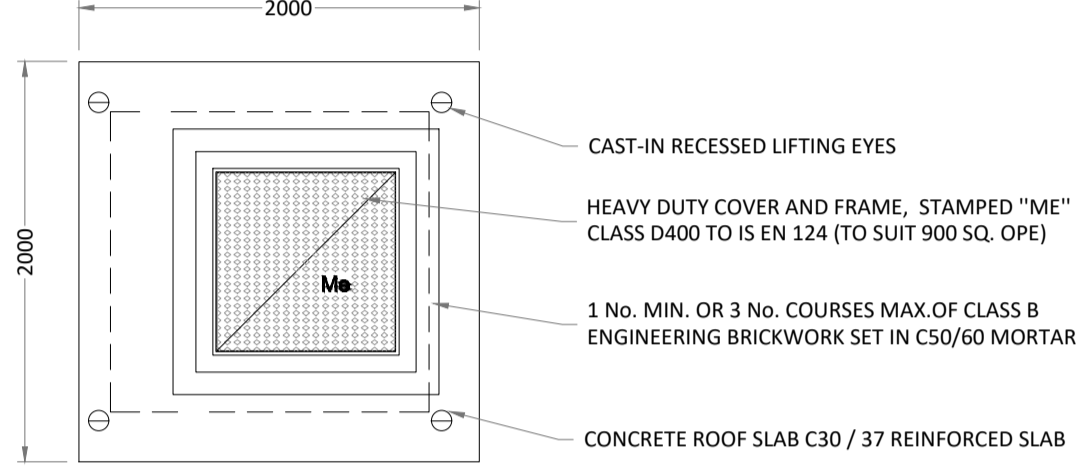

ROOF PLAN

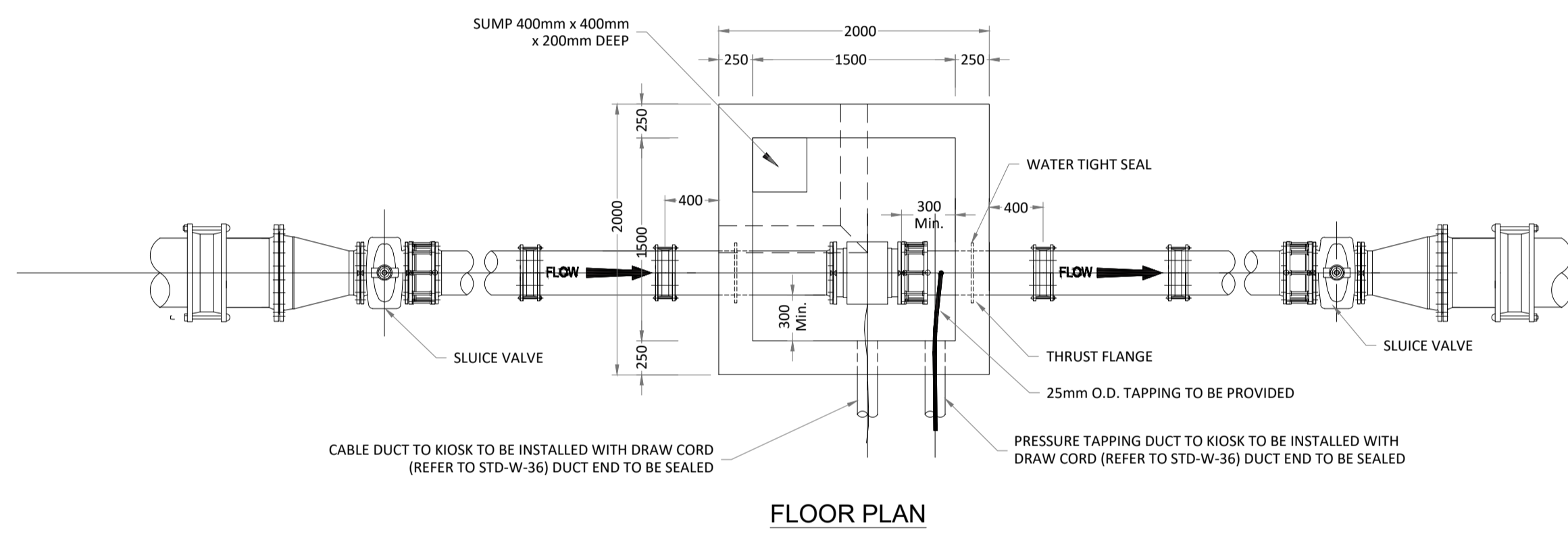

FLOOR PLAN

METER CHAMBER (< 300mm DIA.)

THIS DETAIL APPLIES TO WHERE THE FINISHED SURFACE IS EITHER UNBOUND (GRASS VERGE), BRICK PAVING OR MACADAM, & WHERE A CONCRETE PLINTH IS REQUIRED TO SUPPORT THE TOP OF THE BOUNDARY BOX.

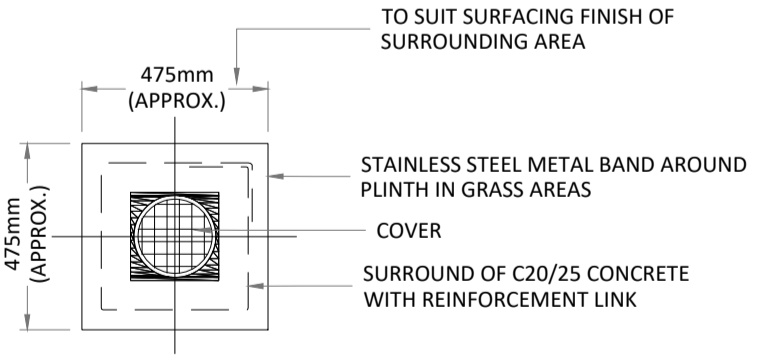

PLAN

CONCRETE SURROUND TO BOUNDARY BOX COVER

- FOR SETTING OUT REFER TO ARCHITECT'S DRAWINGS.
- THIS DRAWING TO BE READ IN CONJUNCTION WITH ALL OTHER ARCHITECTURAL AND ENGINEERING DRAWINGS AND ALL OTHER RELEVANT DRAWINGS AND SPECIFICATIONS.
- DO NOT SCALE THIS DRAWING. USE FIGURED DIMENSIONS ONLY.
- NO PART OF THIS DOCUMENT MAY BE REPRODUCED OR TRANSMITTED IN ANY FORM OR STORED IN ANY RETRIEVAL SYSTEM OF ANY NATURE WITHOUT THE WRITTEN PERMISSION OF O'CONNOR SUTTON CRONIN AS COPYRIGHT HOLDER EXCEPT AS AGREED FOR USE ON THE PROJECT FOR WHICH THE DOCUMENT WAS ORIGINALLY ISSUED.

| Rev No. | Date | Revision Note | Drn by | Chkd by |
|---------|----------|-------------------|--------|---------|
| P01 | 16.02.23 | FOR INFORMATION | TD | TOD |
| P02 | 16.08.23 | ISSUED FOR TENDER | AD | TD |

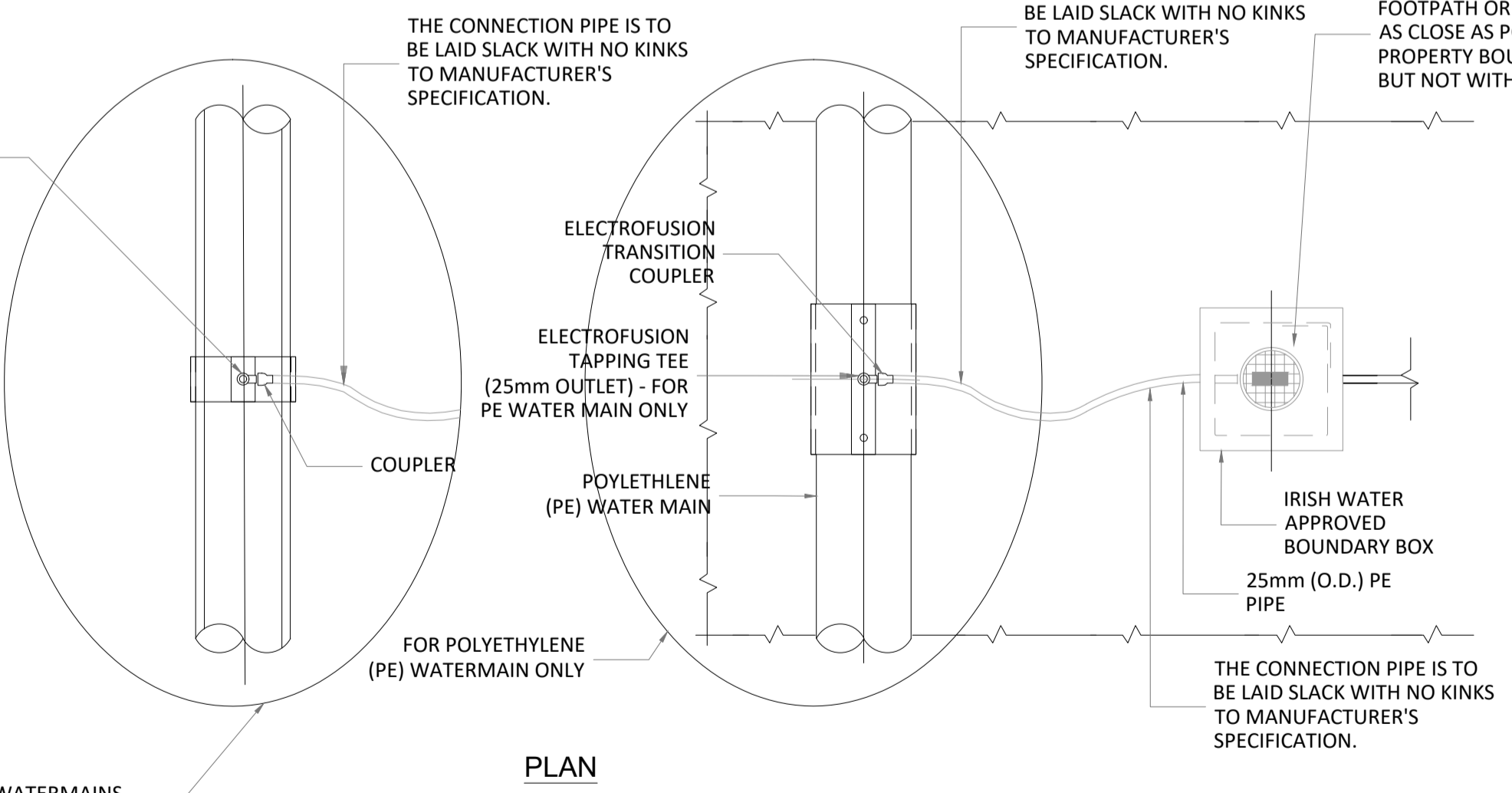

PLAN

CUSTOMER CONNECTION AND BOUNDARY BOX (25mm OD PIPE)

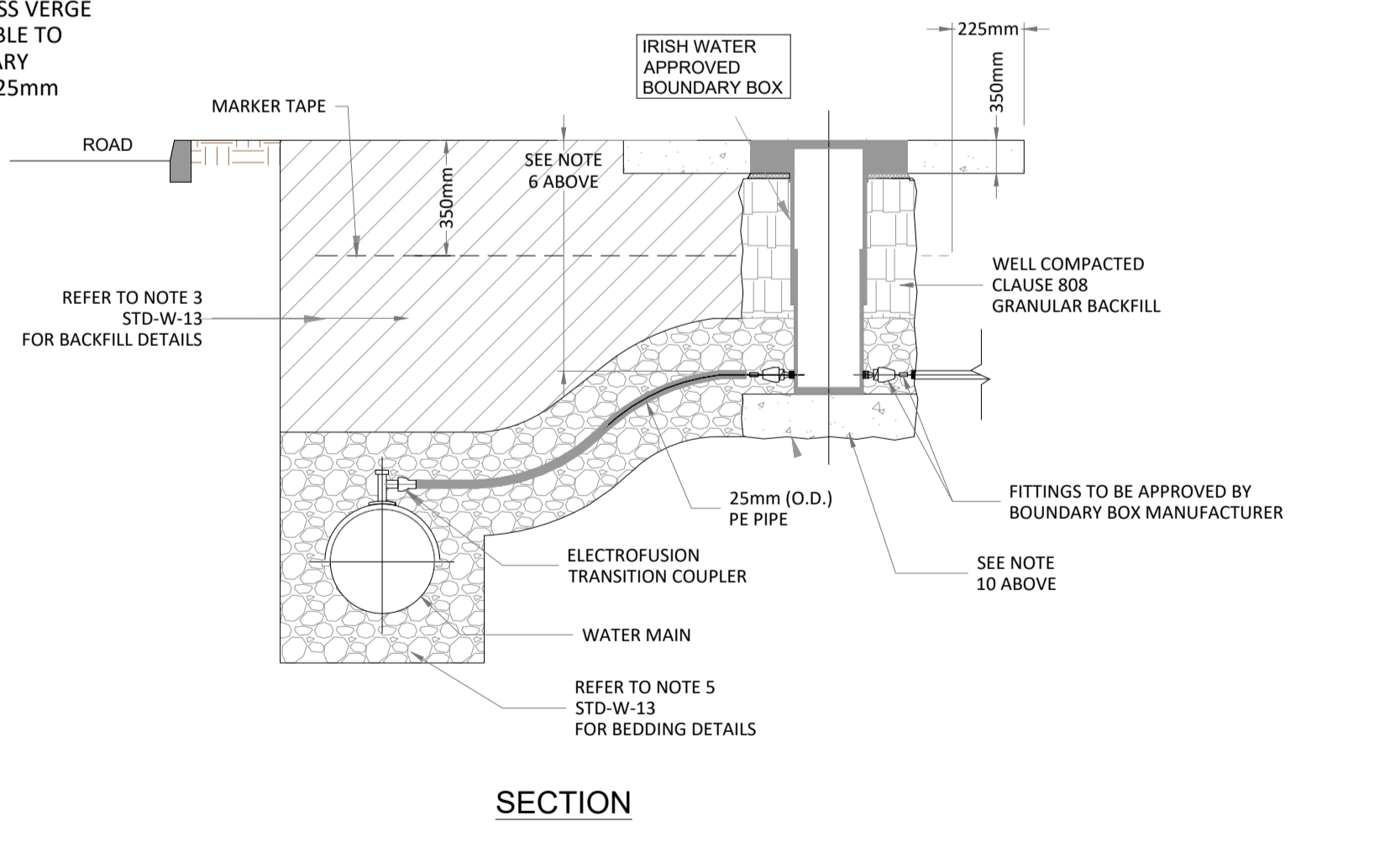

SECTION

| Rev No. | Date | Revision Note | Drn by | Chkd by |
|---------|------|---------------|--------|---------|
| | | | | |

GENERAL NOTES:

- ALL DIMENSIONS IN MILLIMETRES (mm) UNLESS NOTED OTHERWISE.
- CONCRETE CHAMBERS SHALL BE SURROUNDED BY A MINIMUM OF 150mm COMPACTED CLAUSE 808 MATERIAL AS PER STD-W-1.
- DUCTILE IRON PIPES AND FITTINGS TO BE IN ACCORDANCE WITH IS EN 545. PE PIPES AND FITTINGS TO BE IN ACCORDANCE WITH IS EN 12201:2011.
- 200mm ALL AROUND, 100mm DEEP CONCRETE PLINTH WITH PROTECTIVE STAINLESS STEEL METAL BAND AROUND COVERS IN GREEN AREAS.
- THRUST BLOCKS (NOT SHOWN ON DRAWING), TO BE PROVIDED AS PER STANDARD DRAWING STD-W-28 AT ALL TEES, BENDS, TAPERS, DEAD ENDS AND PIPES AT STEEP SLOPES.
- ANTI CORROSION TAPE TO BE PROVIDED AROUND BURIED FLANGES.
- ALL CONCRETE TO BE IN ACCORDANCE WITH IS EN 206.

SLUISE VALVE NOTES:

- SLUISE VALVE CHAMBERS SHALL BE COVERED WITH APPROVED HEAVY DUTY METAL COVERS TO IS 261 OR BS 5834. COVER AND FRAME SHALL BE SUITABLE FOR ROAD AND TRAFFIC CONDITIONS AND IS SUBJECT TO THE APPROVAL OF IRISH WATER.
- SLUISE VALVES SHALL BE RESILIENT SEATED AND SHALL COMPLY WITH BS 5163-1, BS 5163-2, IS EN 1074-1, IS EN 1074-2, OR EQUIVALENT G.U. SPECIFICATIONS.
- ALL SLUISE VALVES SHALL BE ANTI-CLOCKWISE CLOSING.
- VALVE CHAMBER TO BE CONSTRUCTED OF PRECAST CONCRETE UNITS OR HIGH DENSITY BLOCKWORK. ALTERNATIVELY PROPRIETARY PREFABRICATED CHAMBER UNITS MAY ALSO BE USED, SUBJECT TO APPROVAL FROM IRISH WATER.

HYDRANT NOTES:

- HYDRANT CHAMBERS SHALL BE COVERED WITH APPROVED HEAVY DUTY METAL COVERS TO IS 261 OR BS 5834. COVER AND FRAME SHALL BE SUITABLE FOR ROAD AND TRAFFIC CONDITIONS AND IS SUBJECT TO THE APPROVAL OF IRISH WATER.
- ALL HYDRANTS, SURFACE BOX FRAMES & COVERS SHALL COMPLY WITH THE RELEVANT PROVISIONS OF IS EN 14399, IS EN 1074-6 & BS 750. FIRE HYDRANTS SHALL BE TYPE 2. THE HYDRANT INLET SHALL BE 80mm DIAMETER WITH PN16.
- ALL HYDRANTS SHALL BE CLOCKWISE CLOSING.
- HYDRANT CHAMBER TO BE CONSTRUCTED OF PRECAST CONCRETE UNITS OR HIGH DENSITY BLOCKWORK. ALTERNATIVELY PROPRIETARY PREFABRICATED CHAMBER UNITS MAY ALSO BE USED, SUBJECT TO APPROVAL FROM IRISH WATER.

METER CHAMBER NOTES:

- STRUCTURAL DESIGN AND REINFORCEMENT DETAIL TO BE PROVIDED BY THE DEVELOPER AND SUBMITTED TO IRISH WATER FOR REVIEW.
- CONCRETE FOR FLOW METER CHAMBER TO BE C30 / 37.
- PRECAST METER CHAMBER (WITH CONCRETE SURROUND) MAY BE USED SUBJECT TO APPROVAL FROM IRISH WATER.
- METER CHAMBER SHALL BE COVERED WITH APPROVED HEAVY DUTY METAL COVERS TO IS EN 124 RATING D400. COVER AND FRAME SHALL BE SUITABLE FOR ROAD AND TRAFFIC CONDITIONS AND IS SUBJECT TO THE APPROVAL OF IRISH WATER.
- ANTI CORROSION TAPE TO BE PROVIDED AROUND BURIED FLANGES.
- ALL CHAMBERS TO BE CHECKED FOR UPLIFT BY THE DEVELOPER BASED ON GROUND CONDITIONS WITHIN THE SITE. SHOULD ANTI FLOATION MEASURES BE REQUIRED THEY SHALL BE SUBJECT TO APPROVAL FROM IRISH WATER.
- PIPEWORK TO BE DOWNSIZED TO ACCOMMODATE THE REQUIRED RANGE OF THE FLOW METER. STRAIGHT PIPE LENGTHS UPSTREAM AND DOWNSTREAM OF THE METER TO BE PROVIDED. IF THE METER IS NOT CAPABLE OF ACCURATE NIGHT FLOW MEASUREMENTS, A BY-PASS FLOW METER SHALL BE PROVIDED WITH APPROPRIATE VALVES, FITTINGS AND PIPEWORK.

BOUNDARY BOX NOTES:

- THE BOUNDARY BOX IS TO BE IN ACCORDANCE WITH THE IRISH WATER SPECIFICATION, INCORPORATING A G1.5 MANIFOLD, STOP-TAP, FROST PLUG & NON-RETURN VALVE.
- THE BOUNDARY BOX SHALL BE POSITIONED IN PUBLIC SPACE & AS CLOSE AS POSSIBLE TO THE PROPERTY BOUNDARY BUT NO PART OR FITTING TO BE WITHIN 225mm OF THE PROPERTY LINE.
- THE BOUNDARY BOX SHALL BE LOCATED WHERE IT IS SAFE TO OPEN THE COVER & ACCESS THE STOP TAP OR VISUALLY READ THE METER, i.e. ON A FOOTPATH OR VERGE, & NOT IN A CARRIAGEWAY.
- THE SURFACE BOX COVER ON THE BOUNDARY BOX SHOULD BE NOT LESS THAN GRADE C (BS 5834.2-2011); & THE BOUNDARY BOX SHOULD BE LOCATED SUCH THAT HEAVIER GRADES OF COVER WOULD NOT BE REQUIRED.
- THE SHAFT OF THE BOUNDARY BOX IS TO BE INSTALLED VERTICALLY, & THE SURFACE BOX/COVER INCLINED TO MATCH THE SURFACE GRADIENT.
- THE BOUNDARY BOX IS TO BE INSTALLED AT A MINIMUM DEPTH OF 600mm (+/- 25mm) TO THE CROWN OF THE INLET & OUTLET FITTINGS ON THE OUTSIDE OF THE BOX.
- THE SERVICE CONNECTION PIPE SHALL NOT BE WRAPPED AROUND THE SHAFT OF THE BOUNDARY BOX OR BENT IN ANY RADIUS LESS THAN THAT APPROVED BY THE MANUFACTURER.
- THE PIPE FITTINGS TO THE BOUNDARY BOX SHALL BE APPROVED BY THE BOUNDARY BOX MANUFACTURER.
- THE BOUNDARY BOX SHALL BE INSTALLED HYGIENICALLY & LEFT CLEAN & FREE OF CONSTRUCTION WASTE OR DIRT FOR LATER METER INSTALLATION BY IRISH WATER.
- BOX TO BE FOUNDED ON 100mm DEPTH OF C12/15 CONCRETE AND SURROUNDED WITH CLAUSE 808 GRANULAR MATERIAL.
- THE DESIRABLE MINIMUM DEPTH OF COVER FROM THE FINISHED GROUND LEVEL TO THE EXTERNAL CROWN OF A SERVICE CONNECTION SHALL BE 750mm WITH AN ABSOLUTE MINIMUM DEPTH OF 600mm FOR SHORT DISTANCES (SUBJECT TO IRISH WATER AGREEMENT).

CUSTOMER CONNECTION AND BOUNDARY BOX NOTES:

- FOR CONNECTION TO AN EXISTING MAIN THE CONNECTION SHALL BE AS PER THE PIPE MANUFACTURER'S SPECIFICATION.
- ELECTRO FUSION COUPLING TO BE INSTALLED IN ACCORDANCE WITH MANUFACTURER'S INSTRUCTIONS.

WATERMAIN STANDARD DETAILS

SCALE 1:25

TENDER DRAWING
NOT FOR CONSTRUCTION
THIS DRAWING HAS BEEN ISSUED FOR INFORMATION PURPOSES ONLY AND MUST NOT BE USED FOR CONSTRUCTION UNDER ANY CIRCUMSTANCES

| | | | | | | | | | |
|----------|--|--------|-------|------|---------|--------|----------|----------|-----------|
| Client: | SLIGO COUNTY COUNCIL | | | | | | | | |
| Project: | ASH LANE GROUP HOUSING | | | | | | | | |
| Title: | WATERMAIN STANDARD DETAILS SHEET 1 OF 3 | | | | | | | | |
| Code | Originator | Zone | Level | Type | Role | Number | Status | Revision | |
| S603 | OCSC | XX | XX | DR | C | 0631 | D2 | P02 | |
| Date: | FEB '23 | Scale: | A.N. | @ A1 | Drn by: | TD | Chkd by: | TOD | Aprvd by: |

2nd Floor, Technology House,
Galway Technology Park,
Parkmore,
Galway.

TEL +353 (0)91 771360

e: galway@ocsc.ie
w: www.ocsc.ie

Dublin | London | Belfast | Galway | Cork | Birmingham

SLIGO COUNTY COUNCIL

OCSC
O'CONNOR | SUTTON | CRONIN
Multidisciplinary Consulting Engineers

bsi
BSI Registered
Consulting Engineer
ISO 9001:2015
CERTIFIED

NSAI Certified
NSAI Certified
NSAI Certified

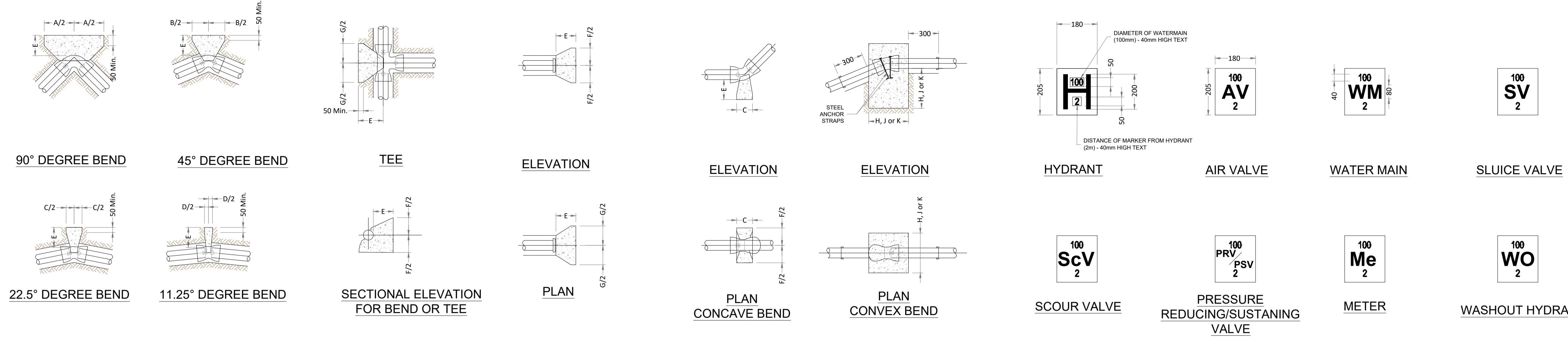

THRUST BLOCKS NOTES:

- CONCRETE THRUST BLOCKS (ANCHORAGE) SHALL BE POSITIONED SYMMETRICALLY WITH RESPECT TO THE CONNECTING PIPE & BENDS.
- TRENCH DIMENSIONS - REFER TO DRAWING No.s STD-W.
- THRUST BLOCKS SHALL BEAR ON UNDISTURBED SOIL. IF FOR ANY REASON THEY CAN NOT THEN THE DEVELOPER SHALL NOTIFY IRISH WATER IMMEDIATELY WITH A PROPOSED SOLUTION.
- THRUST BLOCK REINFORCEMENT REQUIRES SPECIFIC DESIGN.
- FOR TEST PRESSURES GREATER THAN 18 BAR, THRUST BLOCK DESIGN IS TO BE SUBMITTED TO IRISH WATER FOR APPROVAL.
- THRUST BLOCKS ARE DESIGNED FOR AN AVERAGE BEARING PRESSURE OF 100 KN/m (TYPICAL FOR SOFT CLAY) FOR OTHER CONDITIONS, ACTUAL DIMENSIONS MAY BE ALTERED ON INSTRUCTIONS FROM IRISH WATER.
- CONCRETE IN THRUST BLOCKS SHALL BE GRADE C20/25.
- COMPRESSIBLE FILLER FOR CONCRETE PROTECTION TO BE IN ACCORDANCE WITH BS EN622-1 AND BS EN 622-4. BITUMINOUS MATERIAL SHALL NOT BE PUT IN CONTACT WITH PLASTIC PIPES. THE THICKNESS OF COMPRESSIBLE FILLER FOR MAINS < 450mm IN DIAMETER IS TO BE 18mm.
- CONCRETE THRUST BLOCKS FOR POLYETHYLENE PIPE TO COMPLY WITH THE MANUFACTURERS REQUIREMENTS.
- POLYETHYLENE PIPES SHALL BE WRAPPED IN PLASTIC SHEETING HAVING A COMPOSITION IN ACCORDANCE WITH BS 6076 BEFORE BEING CAST INTO CONCRETE.

MARKER POSTS NOTES:

- WHERE PRACTICAL MARKER PLATES SHALL BE FIXED TO ADJACENT WALLS OR ALTERNATIVELY ATTACHED TO MARKER POSTS.
- PLATES TO BE FIXED IN POSITION USING WALL PLUGS AND STAINLESS STEEL SCREWS.
- MARKER PLATES TO BE MANUFACTURED IN ACCORDANCE WITH BS 3251.
- FOR HYDRANT PLATE ALL CHARACTERS SHOULD BE BLACK AND THE REMAINDER OF THE FRONT FACE SHOULD CONFORM TO COLOUR REFERENCE No. 309 (CANARY YELLOW) OF BS 381C.)
- PIPE DIAMETER ON HYDRANT PLATE TO REFER TO WATERMAIN NOT BRANCH.
- SLUICE VALVE, AIR VALVE, SCOUR VALVE, WASHOUT HYDRANT AND METER PLATES SHOULD BE CAST IRON. ALL CHARACTERS SHOULD BE BLACK ON WHITE PAINT BACKGROUND.
- CONCRETE SURROUND TO MARKER POST TO BE GRADE C25/30 AND IN ACCORDANCE WITH BS EN 206/2013.
- PLASTIC MARKER POSTS ARE NOT ACCEPTABLE.

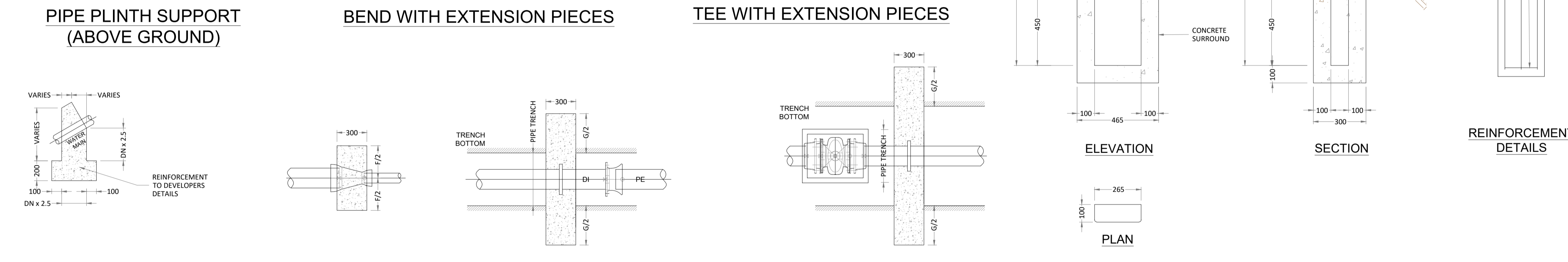
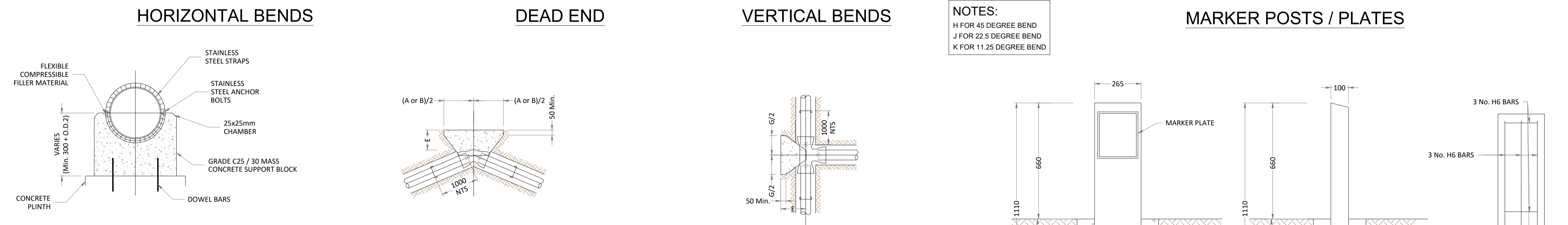

THRUST BLOCKS TABLES:

< 12 BAR TEST PRESSURE

| NOM. DIA. (mm) | DIMENSIONS | | | | | | | | | | |
|----------------|------------|------|------|-----|------|------|------|------|------|------|--|
| | A | B | C | D | E | F | G | H | J | K | |
| 100 | 600 | 330 | 160 | 80 | 200 | 350 | 300 | 700 | 600 | 400 | |
| 150 | 950 | 510 | 260 | 130 | 275 | 450 | 400 | 660 | 900 | 750 | |
| 200 | 1150 | 600 | 310 | 160 | 300 | 600 | 750 | 1050 | 900 | 750 | |
| 250 | 1350 | 750 | 380 | 200 | 300 | 800 | 970 | 1300 | 1000 | 750 | |
| 300 | 1580 | 850 | 450 | 230 | 330 | 950 | 1150 | 1500 | 1300 | 850 | |
| 350 | 1780 | 1000 | 520 | 260 | 400 | 1050 | 1450 | 1750 | 1500 | 950 | |
| 400 | 2050 | 1150 | 600 | 300 | 500 | 1250 | 1800 | 2100 | 1750 | 1000 | |
| 450 | 2300 | 1300 | 680 | 350 | 600 | 1500 | 2150 | 2500 | 2000 | 1150 | |
| 500 | 2550 | 1450 | 780 | 400 | 700 | 1750 | 2500 | 2900 | 2300 | 1250 | |
| 600 | 3300 | 1900 | 1000 | 500 | 900 | 2300 | 3300 | 3900 | 3000 | 1500 | |
| 800 | 4300 | 2500 | 1300 | 650 | 1200 | 3000 | 4300 | 5100 | 4000 | 1900 | |

12 BAR TO 16 BAR TEST PRESSURE

| NOM. DIA. (mm) | DIMENSIONS | | | | | | | | | | |
|----------------|------------|------|------|-----|-----|------|------|------|------|------|--|
| | A | B | C | D | E | F | G | H | J | K | |
| 100 | 700 | 380 | 190 | 100 | 200 | 350 | 310 | 750 | 600 | 400 | |
| 150 | 1110 | 620 | 320 | 160 | 275 | 450 | 760 | 950 | 750 | 600 | |
| 200 | 1400 | 750 | 380 | 190 | 300 | 600 | 980 | 1150 | 950 | 700 | |
| 250 | 1730 | 940 | 480 | 240 | 330 | 800 | 1230 | 1350 | 1050 | 850 | |
| 300 | 2060 | 1130 | 580 | 300 | 350 | 950 | 1480 | 1600 | 1200 | 950 | |
| 350 | 2400 | 1410 | 720 | 360 | 400 | 1050 | 1840 | 1900 | 1350 | 1050 | |
| 400 | 2780 | 1610 | 820 | 420 | 500 | 1200 | 2150 | 2350 | 1500 | 1150 | |
| 450 | 3180 | 1840 | 940 | 470 | 600 | 1350 | 2500 | 2800 | 1600 | 1250 | |
| 500 | 3650 | 2110 | 1130 | 570 | 700 | 1500 | 2900 | 3300 | 1750 | 1350 | |
| 600 | 5010 | 2710 | 1480 | 700 | 900 | 2000 | 3800 | 4500 | 2300 | 1600 | |

16 BAR TO 18 BAR TEST PRESSURE

| NOM. DIA. (mm) | DIMENSIONS | | | | | | | | | | |
|----------------|------------|------|------|-----|------|------|------|------|------|------|--|
| | A | B | C | D | E | F | G | H | J | K | |
| 100 | 750 | 400 | 205 | 100 | 225 | 400 | 330 | 800 | 650 | 450 | |
| 150 | 1200 | 700 | 350 | 180 | 275 | 500 | 850 | 1000 | 850 | 650 | |
| 200 | 1600 | 890 | 450 | 230 | 330 | 700 | 1170 | 1350 | 1000 | 800 | |
| 250 | 1950 | 1090 | 540 | 270 | 350 | 800 | 1370 | 1600 | 1150 | 900 | |
| 300 | 2300 | 1300 | 640 | 320 | 400 | 900 | 1600 | 1850 | 1300 | 1050 | |
| 350 | 2650 | 1500 | 740 | 370 | 500 | 1000 | 2000 | 2200 | 1500 | 1150 | |
| 400 | 3100 | 1800 | 870 | 430 | 600 | 1100 | 2400 | 2600 | 1600 | 1250 | |
| 450 | 3550 | 2100 | 980 | 500 | 700 | 1200 | 2800 | 3100 | 1750 | 1350 | |
| 500 | 4050 | 2400 | 1130 | 610 | 800 | 1300 | 3300 | 3700 | 1900 | 1450 | |
| 600 | 5350 | 3100 | 1500 | 800 | 1000 | 1700 | 4300 | 5000 | 2500 | 1900 | |

TABLE OF DIMENSIONS FOR STEEPLY INCLINED PIPELINES

| GRADIENT | SPACING |
|------------------------|---------|
| 1 IN 2 & STEEPER | 5.5m |
| BELOW 1 IN 2 TO 1 IN 4 | 11.0m |
| 1 IN 4 TO 1 IN 5 | 16.6m |
| 1 IN 5 TO 1 IN 6 | 22.0m |

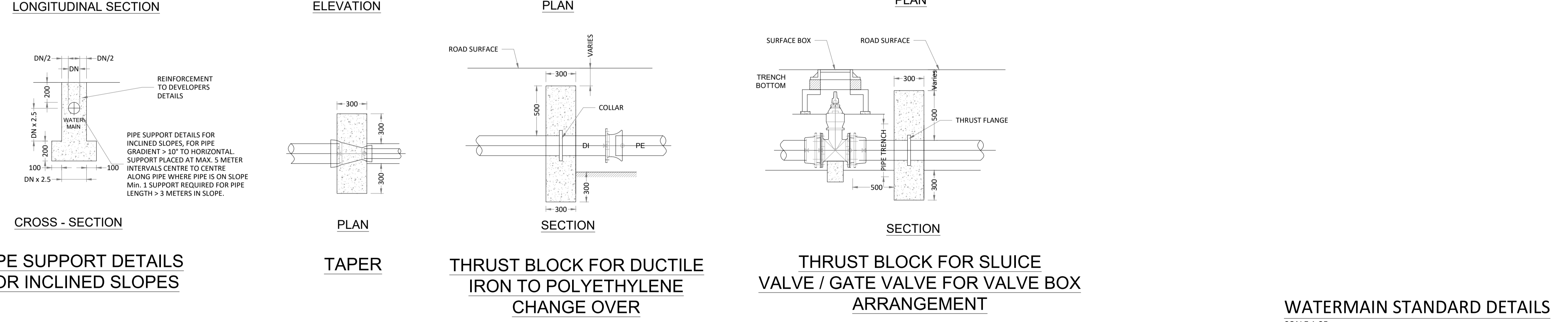

TENDER DRAWING
 NOT FOR CONSTRUCTION
 THIS DRAWING HAS BEEN ISSUED FOR INFORMATION PURPOSES ONLY AND MUST NOT BE USED FOR CONSTRUCTION UNDER ANY CIRCUMSTANCES

- FOR SETTING OUT REFER TO ARCHITECT'S DRAWINGS.
- THIS DRAWING TO BE READ IN CONJUNCTION WITH ALL OTHER ARCHITECTURAL AND ENGINEERING DRAWINGS AND ALL OTHER RELEVANT DRAWINGS AND SPECIFICATIONS.
- DO NOT SCALE THIS DRAWING. USE FIGURED DIMENSIONS ONLY.
- NO PART OF THIS DOCUMENT MAY BE REPRODUCED OR TRANSMITTED IN ANY FORM OR STORED IN ANY RETRIEVAL SYSTEM OF ANY NATURE WITHOUT THE WRITTEN PERMISSION OF O'CONNOR SUTTON CRONIN AS COPYRIGHT HOLDER EXCEPT AS AGREED FOR USE ON THE PROJECT FOR WHICH THE DOCUMENT WAS ORIGINALLY ISSUED.

| Rev No. | Date | Revision Note | Drn by | Chkd by |
|---------|----------|-------------------|--------|---------|
| P01 | 16.02.23 | FOR INFORMATION | TD | TOD |
| P02 | 16.08.23 | ISSUED FOR TENDER | AD | TD |

| Rev No. | Date | Revision Note | Drn by | Chkd by |
|---------|------|---------------|--------|---------|
| | | | | |
| | | | | |

WATERMAIN STANDARD DETAILS
 SCALE 1:25

Client: SLIGO COUNTY COUNCIL
 Project: ASH LANE GROUP HOUSING

Title: WATERMAIN STANDARD DETAILS SHEET 2 OF 3

Code | Originator | Zone | Level | Type | Role | Number | Status | Revision
 S603 - OCSC - XX - XX - DR - C - 0632 D2 P02

Date: FEB '23 Scale: A:N. @ A1 Drn by: TD Chkd by: TOD Aprvd by:

2nd Floor, Technology House, Galway Technology Park, Parkmore, Galway.

TEL +353 (0)91 771360

e: galway@ocsc.ie
 w: www.ocsc.ie

Dublin | London | Belfast | Galway | Cork | Birmingham

bsi
 BS 5958-1
 Certification
 Registered
 ISO 9001:2015
 MEMBER

OCSC
 O'CONNOR | SUTTON | CRONIN
 Multidisciplinary
 Consulting Engineers

SCOUR CHAMBER TO STORM SEWER ARRANGEMENTS NOTES:

- ALL DIMENSIONS ARE IN MILLIMETRES (mm) UNLESS NOTED OTHERWISE.
- STRUCTURAL REINFORCEMENT AND DESIGN DETAIL TO BE PROVIDED BY THE DEVELOPER AND SUBMITTED TO IRISH WATER FOR REVIEW. ROOF SLABS SHALL BE DESIGNED TO CARRY ALL LIVE LOADS & DEAD LOADS, & CONSIST OF A REINFORCED CONCRETE SLAB OF IN-SITU CONCRETE, GRADE C30/37, WITH A MINIMUM THICKNESS OF 225mm. ALTERNATIVELY, PRE-CAST CONCRETE ROOFS MAY BE USED, SUBJECT TO IRISH WATER REVIEW, & COMPLIANCE WITH IS EN 1719 & IS 420
- CONCRETE FOR SCOUR CHAMBER AND HEADWALL TO BE C30 / 37.
- APPROVAL TO BE OBTAINED FROM LOCAL AUTHORITY FOR CONNECTION TO THE EXISTING STORM SEWER.
- SCOUR CHAMBER SHALL BE COVERED WITH APPROVED HEAVY DUTY METAL COVERS TO IS EN 124 RATING D400. COVER AND FRAME SHALL BE SUITABLE FOR ROAD AND TRAFFIC CONDITIONS AND IS SUBJECT TO REVIEW BY IRISH WATER.
- 200mm ALL ROUND, 100mm DEEP CONCRETE PLINTH AROUND COVERS IN GRASS AREAS.
- FINAL DETAIL TO BE REVIEWED BY IRISH WATER AND RELEVANT REGULATORY AUTHORITIES.
- THRUST BLOCKS (NOT SHOWN ON DRAWING), TO BE PROVIDED AS PER STANDARD DRAWING STD-W-28 AT ALL TEES, BENDS, TAPERS, DEAD ENDS AND PIPES AT STEEP SLOPES.
- ANTI CORROSION TAPE TO BE PROVIDED AROUND BURIED FLANGES.
- ALL PIPEWORK AND FITTINGS TO BE IN ACCORDANCE WITH IS EN 545. PE PIPES AND FITTINGS TO BE IN ACCORDANCE WITH IS EN 12201:2011.
- ALL CHAMBERS TO BE CHECKED FOR UPLIFT BY THE DEVELOPER BASED ON GROUND CONDITIONS WITHIN THE SITE. SHOULD ANTI FLOTATION MEASURES BE REQUIRED THEY SHALL BE SUBJECT TO AGREEMENT WITH IRISH WATER.
- ALL CONCRETE TO BE IN ACCORDANCE WITH IS EN 206.
- BACKFILL AND REINSTATEMENT OF RIVER BED AND BANK TO BE SUBJECT TO AGREEMENT WITH IRISH WATER & RELEVANT AUTHORITIES.

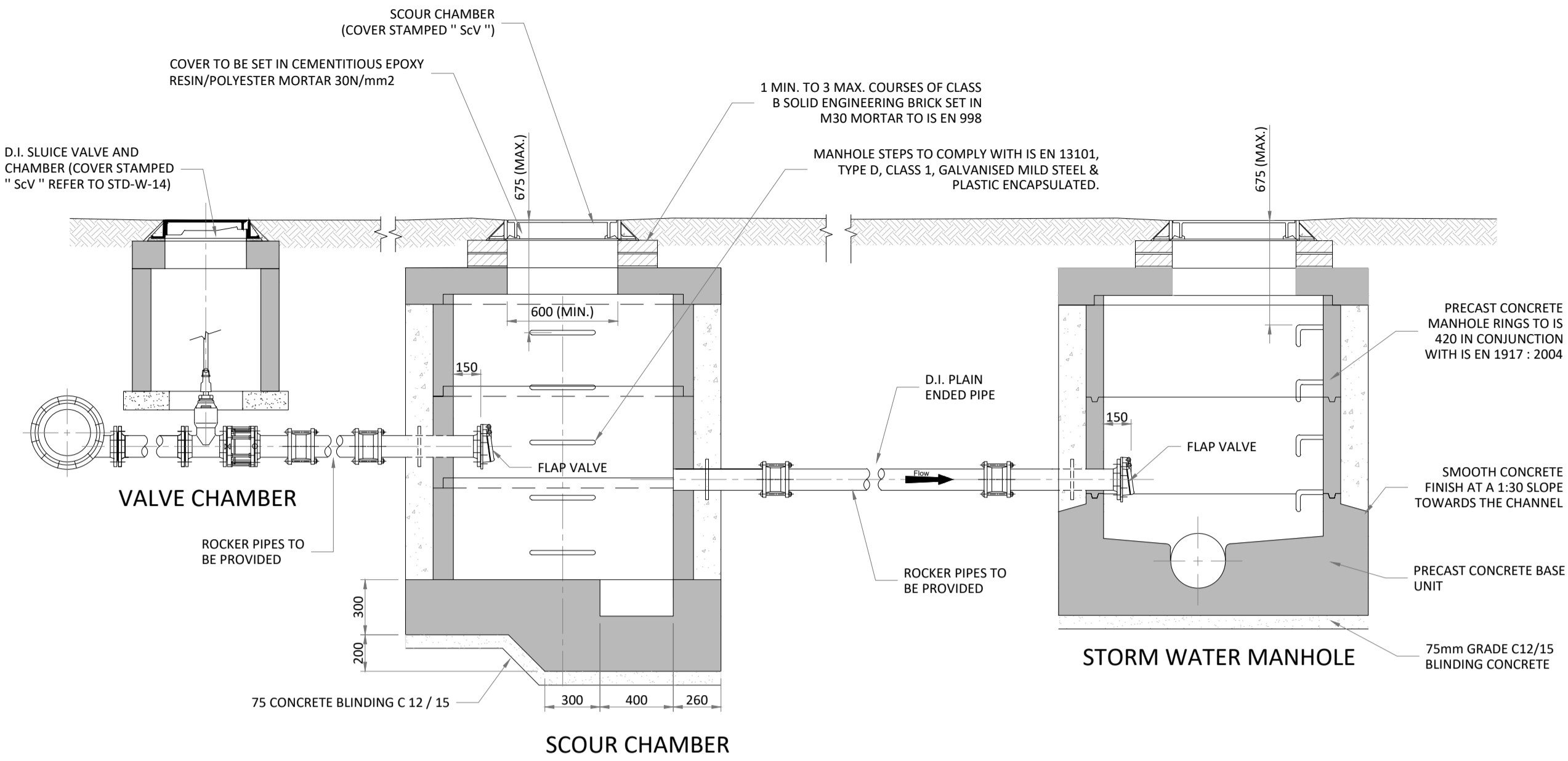

| | | |
|---------------------|----------------|-----------------|
| DIAMETER OF MAIN | UP TO 250 (mm) | 250 TO 350 (mm) |
| DIAMETER OF BRANCH | 80mm | 100mm |
| BORE OF VALVE INLET | 80mm | 100mm |

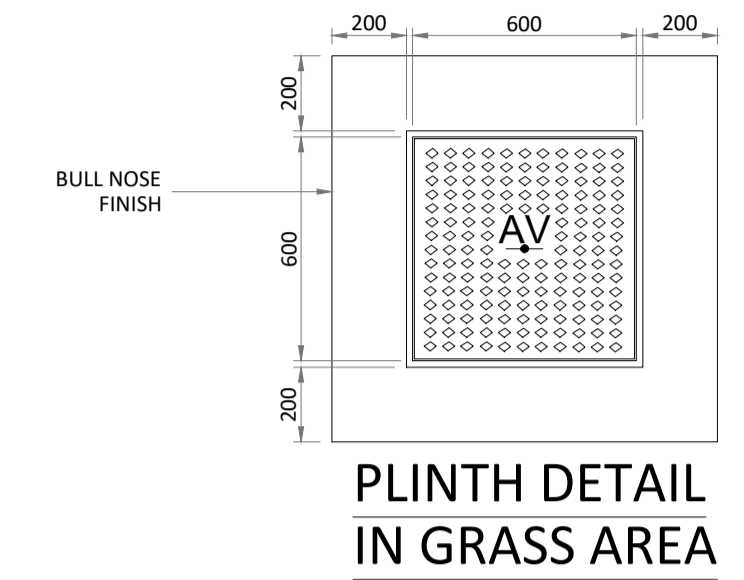

ON-LINE AIR VALVE NOTES:

- ALL DIMENSIONS IN MILLIMETRES (mm) UNLESS NOTED OTHERWISE.
- AIR VALVE CHAMBERS SHALL BE COVERED WITH APPROVED VENTILATED HEAVY DUTY DUCTILE IRON COVERS TO IS EN 124 RATING D400. COVER AND FRAME SHALL BE SUITABLE FOR ROAD AND TRAFFIC CONDITIONS AND IS SUBJECT TO REVIEW BY IRISH WATER.
- AIR VALVES SHALL COMPLY WITH THE REQUIREMENTS OF IS EN 1074-4. AIR VALVES SHALL BE DOUBLE ORIFICE TYPE AND SHALL INCLUDE AN ISOLATING VALVE. THE ISOLATING VALVE SHALL BE EITHER A GATE VALVE CONFORMING TO IS EN 1074-2 & SHALL BE OF A BOLTLESS BONNET DESIGN, OR A BUTTERFLY VALVE TO IS EN 1074-2.
- SERVICE CONNECTIONS SHALL NOT BE PROVIDED WITHIN 2m OF THE AIR VALVE LOCATION.
- AIR VALVE CHAMBERS TO BE OF PRECAST CONCRETE UNITS OR HIGH DENSITY BLOCKWORK. ALTERNATIVE PROPRIETARY PREFABRICATED CHAMBER UNITS MAY ALSO BE USED, SUBJECT TO REVIEW BY IRISH WATER.
- PRECAST CONCRETE CHAMBERS SHALL BE SURROUNDED BY A MINIMUM OF 150mm COMPACTED CLAUSE 808 MATERIAL AS PER STD-W-13.
- DUCTILE IRON PIPES / FITTINGS AND PE PIPES / FITTINGS TO BE IN ACCORDANCE WITH IS EN 545 AND IS EN 12201:2011.
- 200mm ALL AROUND, 100mm DEEP CONCRETE PLINTH AROUND COVERS IN GRASS AREAS.
- THRUST BLOCKS (NOT SHOWN ON DRAWING), TO BE PROVIDED AS PER STANDARD DRAWING STD-W-28 AT ALL TEES, BENDS, TAPERS, DEAD ENDS AND PIPES AT STEEP SLOPES.
- ANTI CORROSION TAPE TO BE PROVIDED AROUND BURIED FLANGES.
- THE LOCATION OF THE AIR VALVE SHALL BE THE SUBJECT OF PARTICULAR AGREEMENT WITH IRISH WATER TO ENSURE THAT THE RISK OF CONTAMINATION THROUGH THE VALVE IS ELIMINATED.
- ALL CONCRETE TO BE IN ACCORDANCE WITH IS EN 206.
- ANY SPECIAL ROAD REINSTATEMENT AROUND COVER & FRAME SHALL BE TO ROAD AUTHORITY'S REQUIREMENTS.
- NEW ROAD CONSTRUCTION & SURFACE FINISH TO BE TO ROAD AUTHORITY REQUIREMENTS.
- EXISTING ROAD REINSTATEMENT TO COMPLY WITH CURRENT VERSION OF "GUIDELINES FOR MANAGING OPENINGS IN PUBLIC ROADS" BY THE DEPT. OF TRANSPORT, TOURISM & SPORT, OR TRANSPORT INFRASTRUCTURE IRELAND REQUIREMENTS.

| DIAMETER OF WATERMAIN (mm) | DIAMETER OF SCOUR (mm) |
|----------------------------|------------------------|
| NOT EXCEEDING 75 | 50 |
| 100 TO 200 | 75 |
| 200 TO 350 | 100 |

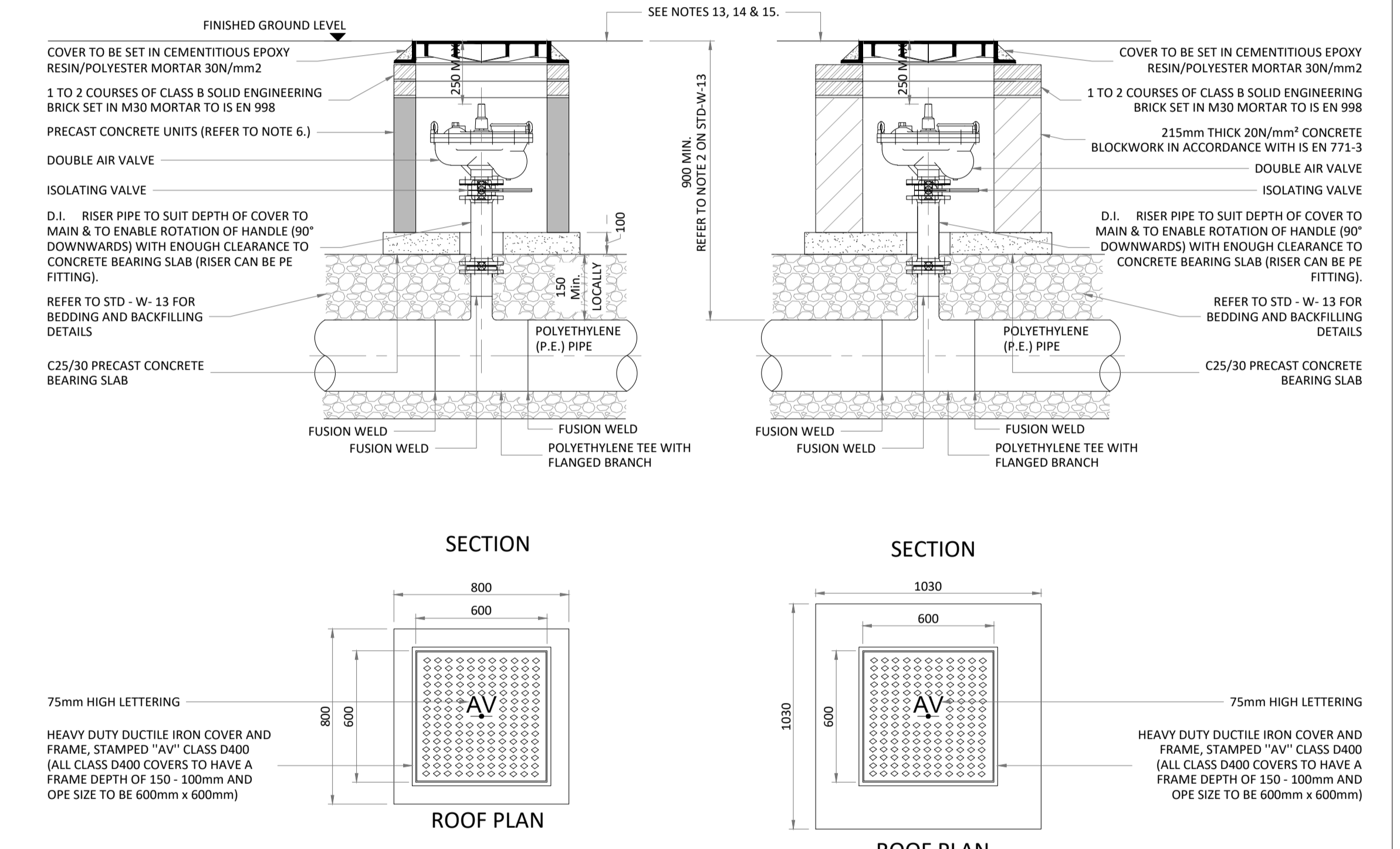
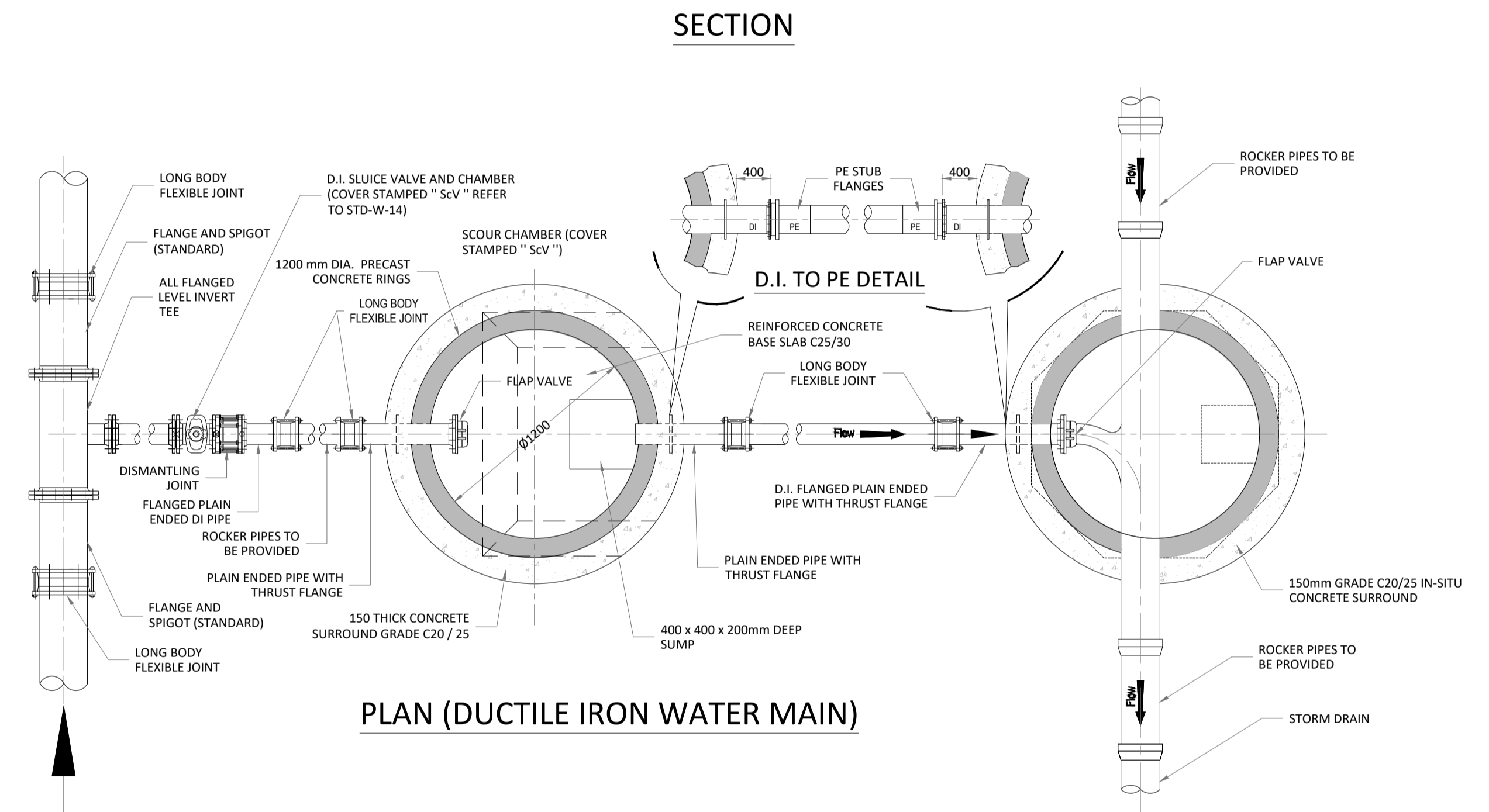

WATERMAIN STANDARD DETAILS SCALE 1:25

- FOR SETTING OUT REFER TO ARCHITECT'S DRAWINGS.
- THIS DRAWING TO BE READ IN CONJUNCTION WITH ALL OTHER ARCHITECTURAL AND ENGINEERING DRAWINGS AND ALL OTHER RELEVANT DRAWINGS AND SPECIFICATIONS.
- DO NOT SCALE THIS DRAWING. USE FIGURED DIMENSIONS ONLY.
- NO PART OF THIS DOCUMENT MAY BE REPRODUCED OR TRANSMITTED IN ANY FORM OR STORED IN ANY RETRIEVAL SYSTEM OF ANY NATURE WITHOUT THE WRITTEN PERMISSION OF O'CONNOR SUTTON CRONIN AS COPYRIGHT HOLDER EXCEPT AS AGREED FOR USE ON THE PROJECT FOR WHICH THE DOCUMENT WAS ORIGINALLY ISSUED.

PLAN (POLYETHYLENE WATER MAIN)

| Rev No. | Date | Revision Note | Drn by | Chkd by |
|---------|----------|-------------------|--------|---------|
| PO1 | 16.02.23 | FOR INFORMATION | TD | TOD |
| PO2 | 16.08.23 | ISSUED FOR TENDER | AD | TD |

ROOF PLAN

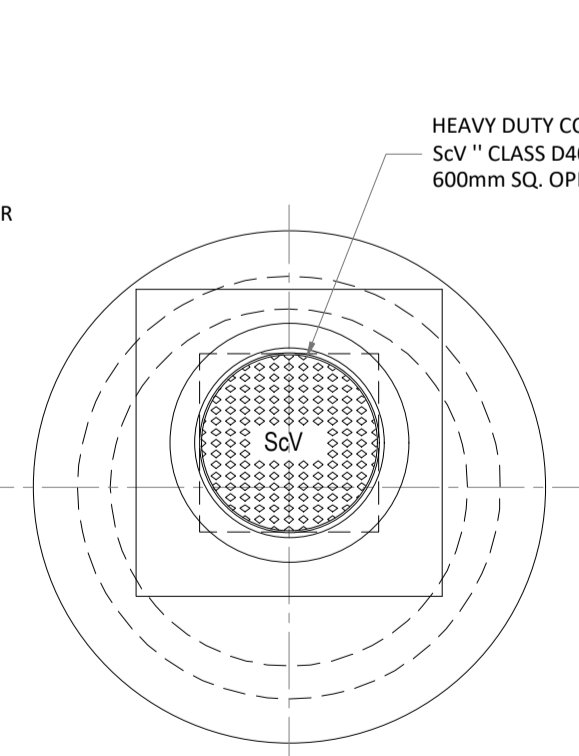

TENDER DRAWING NOT FOR CONSTRUCTION
THIS DRAWING HAS BEEN ISSUED FOR INFORMATION PURPOSES ONLY AND MUST NOT BE USED FOR CONSTRUCTION UNDER ANY CIRCUMSTANCES

FLOOR PLAN DOUBLE AIR VALVE (PRECAST CONCRETE CONSTRUCTION)

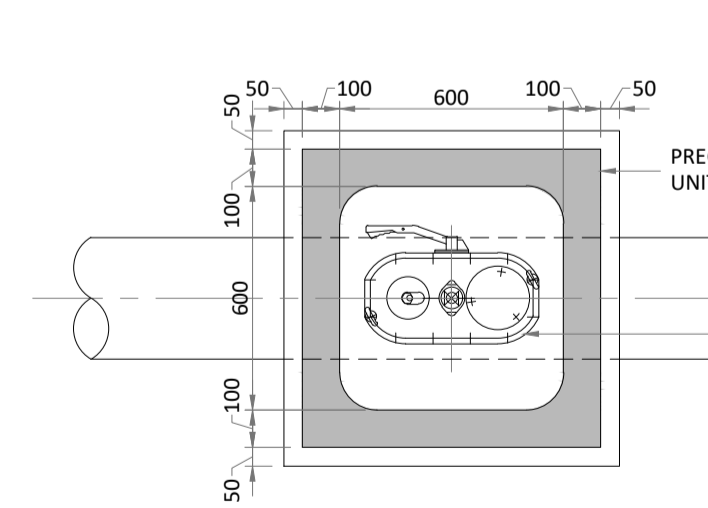

FLOOR PLAN DOUBLE AIR VALVE (BLOCKWORK CONSTRUCTION)

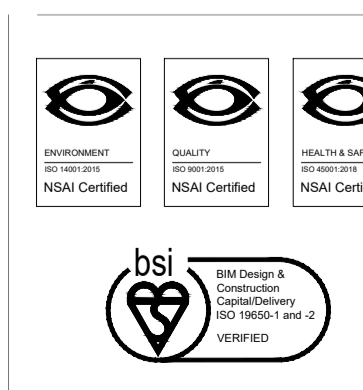
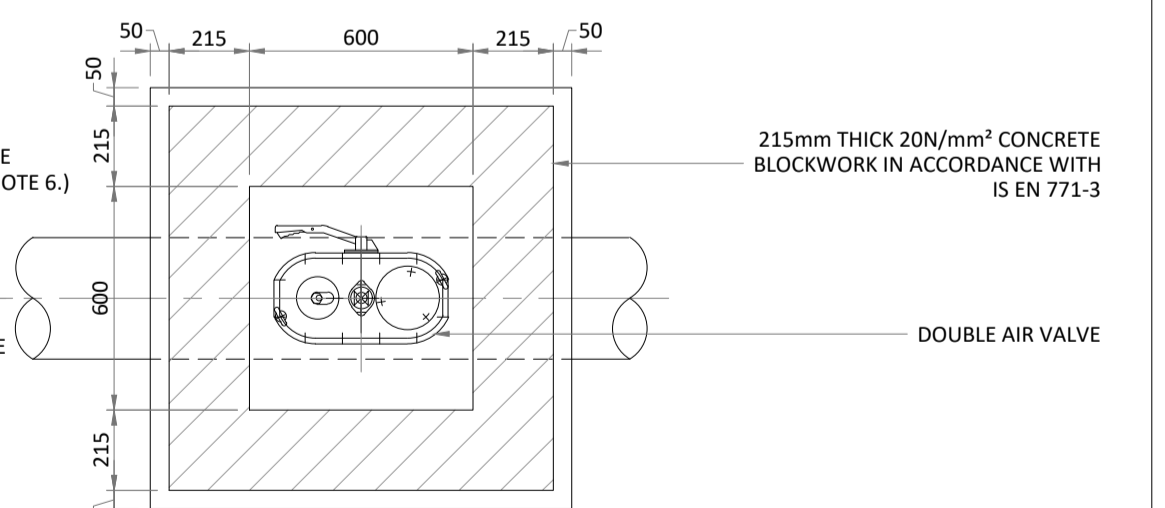

2nd Floor, Technology House,
Galway Technology Park,
Parkmore,
Galway.

TEL +353 (0)91 771360
e: galway@ocsc.ie
w: www.ocsc.ie

Dublin | London | Belfast | Galway | Cork | Birmingham



Client: SLIGO COUNTY COUNCIL
Project: ASH LANE GROUP HOUSING

Title: WATERMAIN STANDARD DETAILS
SHEET 3 OF 3

Code | Originator | Zone | Level | Type | Role | Number | Status | Revision
S603 - OCSC - XX - XX - DR - C - 0633 | D2 | PO2
Date: FEB '23 Scale: A.N. @ A1 Drn by: TD Chkd by: TOD Aprvd by:

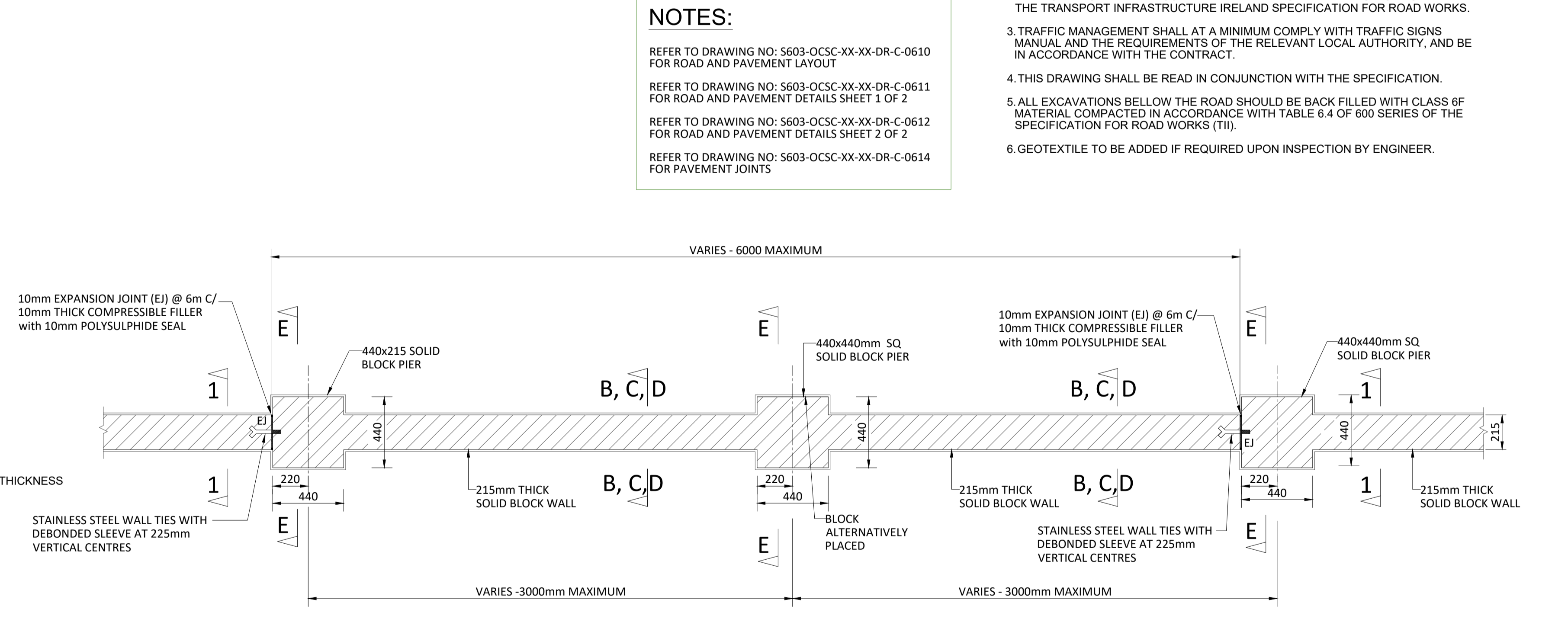
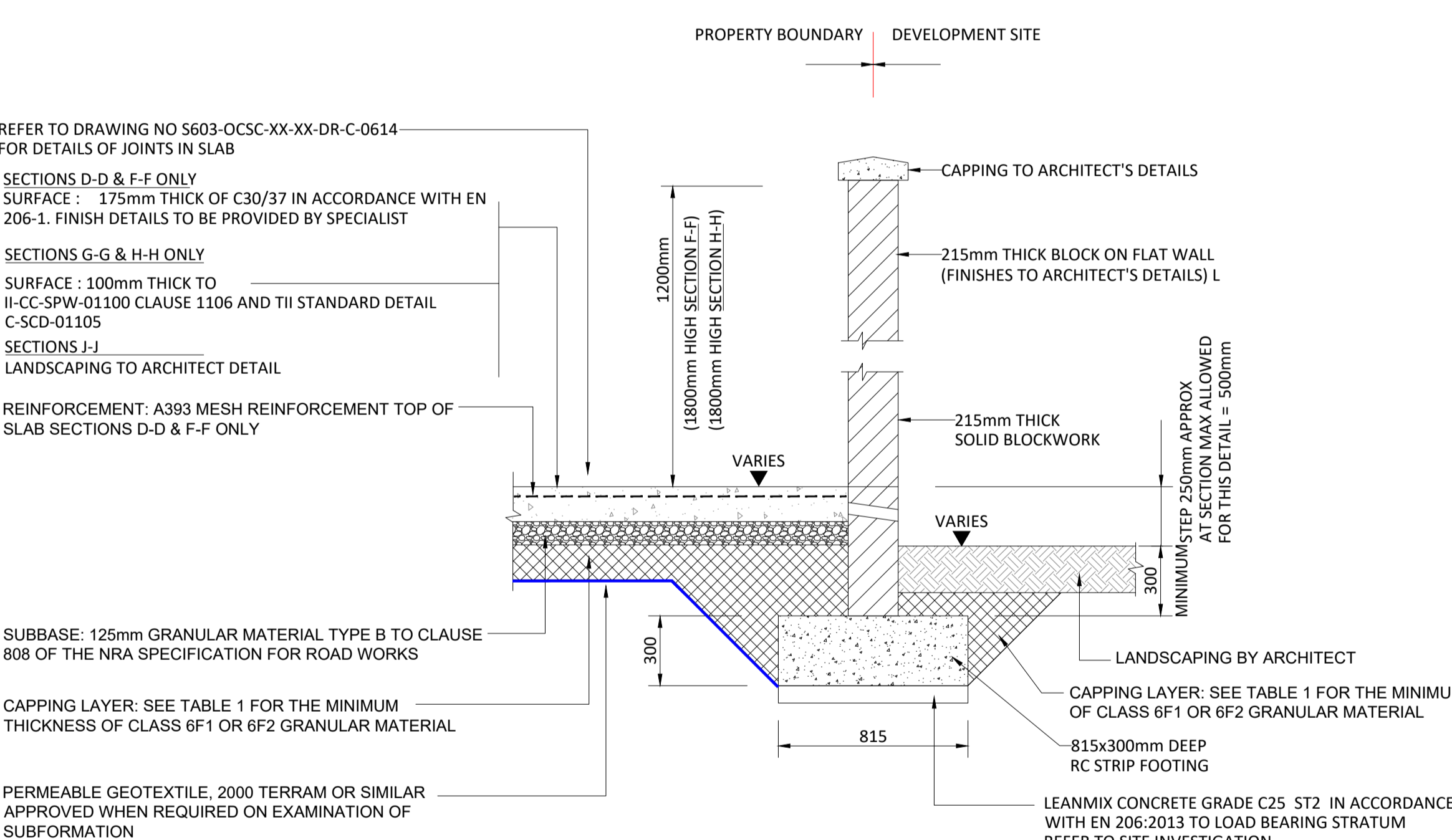
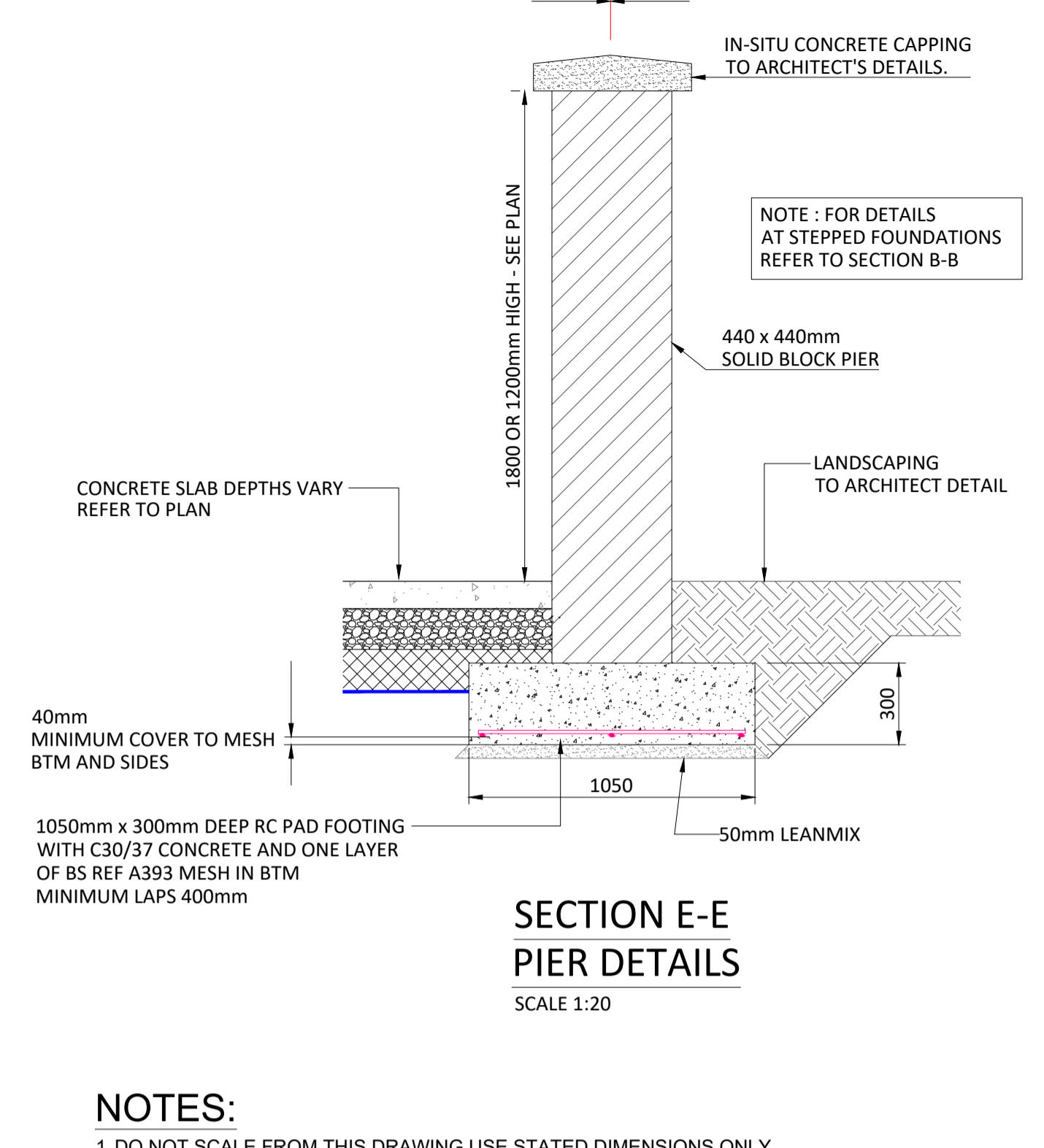
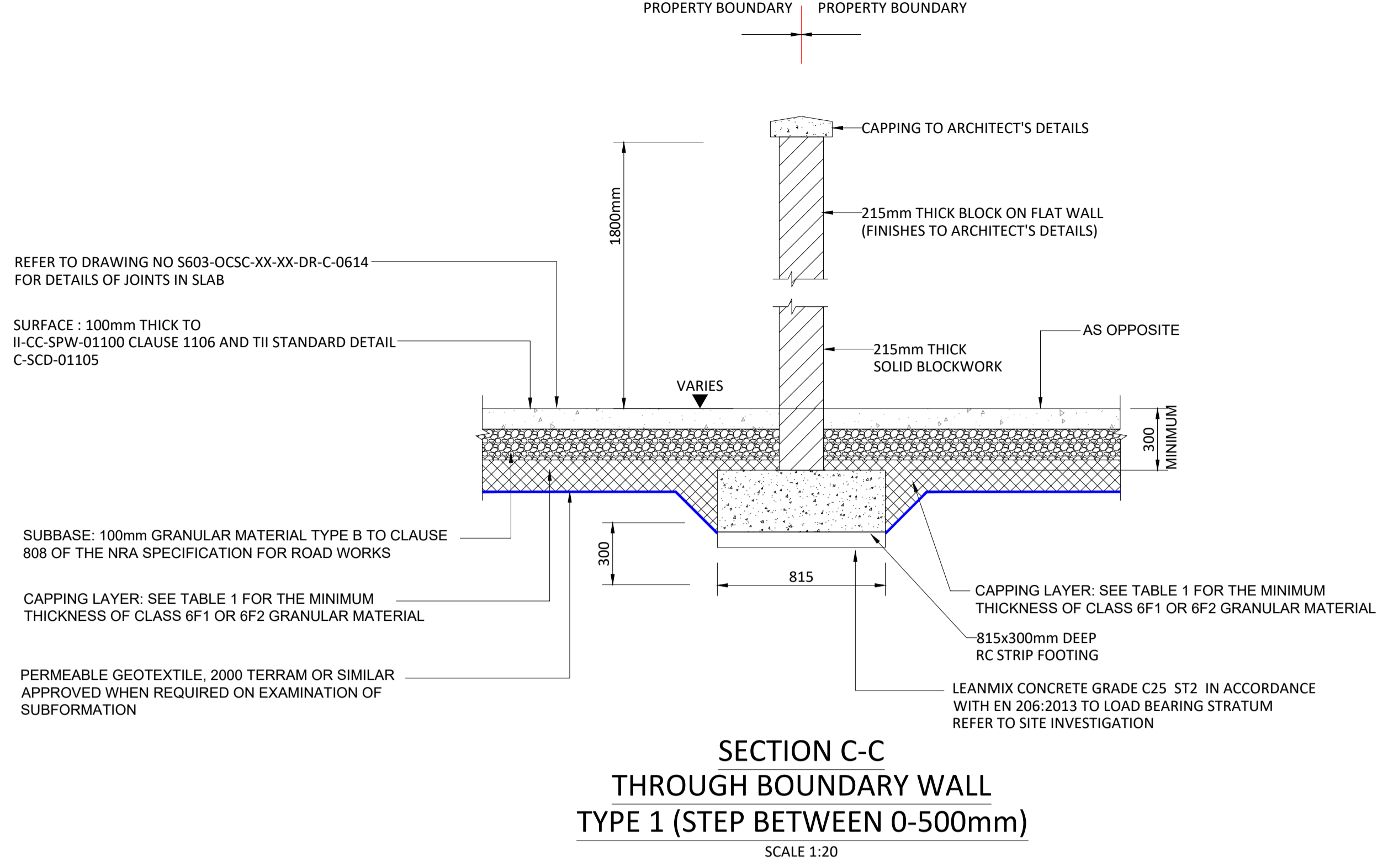
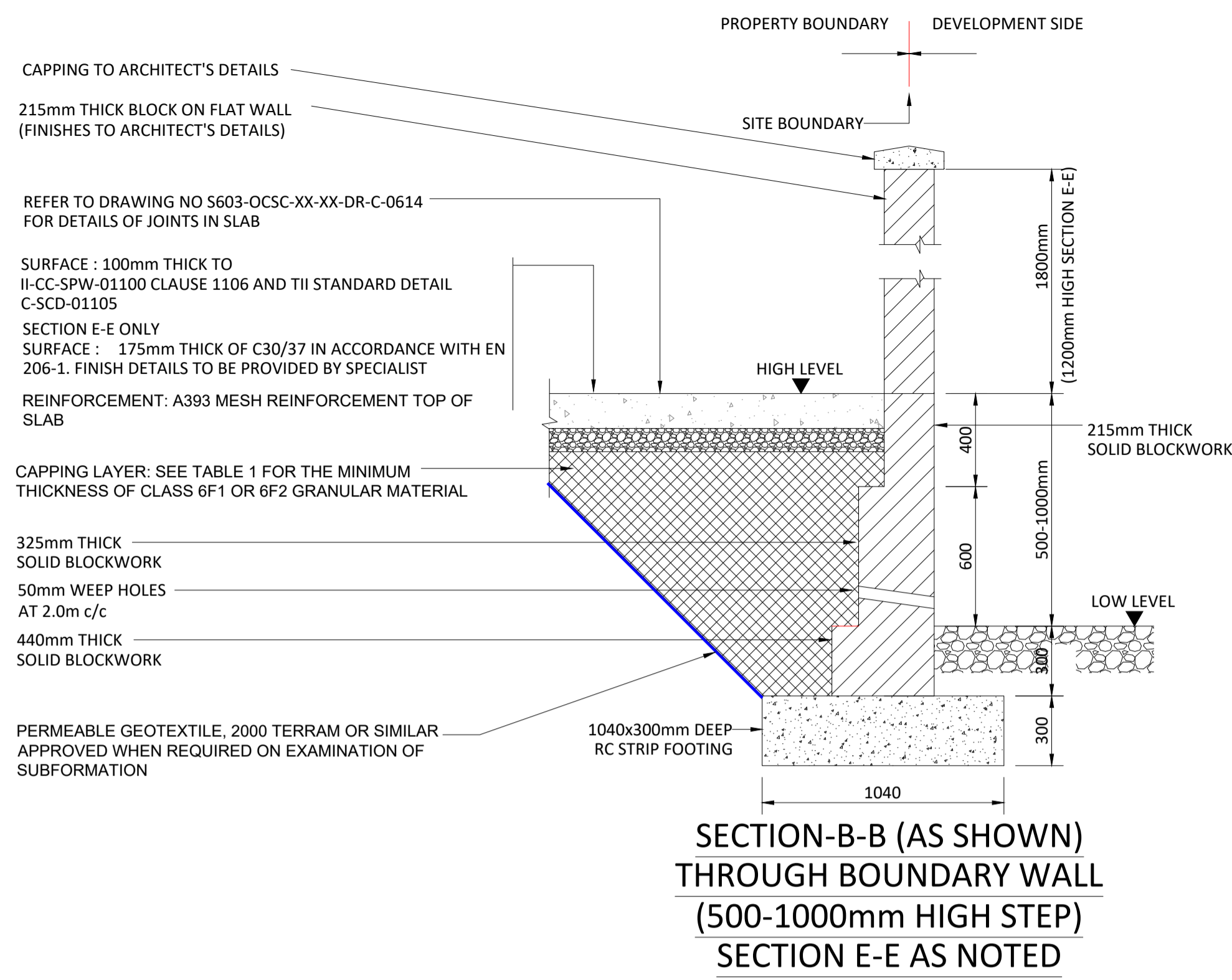

NOTES:

REFER TO DRAWING NO: S603-OCSC-XX-XX-DR-C-0610 FOR ROAD AND PAVEMENT LAYOUT

REFER TO DRAWING NO: S603-OCSC-XX-XX-DR-C-0611 FOR ROAD AND PAVEMENT DETAILS SHEET 1 OF 2

REFER TO DRAWING NO: S603-OCSC-XX-XX-DR-C-0612 FOR ROAD AND PAVEMENT DETAILS SHEET 2 OF 2

REFER TO DRAWING NO: S603-OCSC-XX-XX-DR-C-0614 FOR PAVEMENT JOINTS

NOTES:

- DO NOT SCALE FROM THIS DRAWING USE STATED DIMENSIONS ONLY. IF IN DOUBT CONSULT THE ENGINEER.
- ALL ROAD WORKS SHALL COMPLY WITH THE ENGINEERS SPECIFICATION AND THE TRANSPORT INFRASTRUCTURE IRELAND SPECIFICATION FOR ROAD WORKS.
- TRAFFIC MANAGEMENT SHALL AT A MINIMUM COMPLY WITH TRAFFIC SIGNS MANUAL AND THE REQUIREMENTS OF THE RELEVANT LOCAL AUTHORITY, AND BE IN ACCORDANCE WITH THE CONTRACT.
- THIS DRAWING SHALL BE READ IN CONJUNCTION WITH THE SPECIFICATION.
- ALL EXCAVATIONS BELOW THE ROAD SHOULD BE BACK FILLED WITH CLASS 6F MATERIAL COMPACTED IN ACCORDANCE WITH TABLE 6.4 OF 600 SERIES OF THE SPECIFICATION FOR ROAD WORKS (TII).
- GEOTEXTILE TO BE ADDED IF REQUIRED UPON INSPECTION BY ENGINEER.

SECTION D-D THROUGH BOUNDARY WALL TYPE 1 (STEP BETWEEN 0-500mm HIGH)

SECTION F-F AS NOTED

SECTION G-G AS NOTED

SECTION H-H AS NOTED

SECTION J-J AS NOTED

SCALE 1:20

PLAN OF BOUNDARY WALL - TYPICAL EXPANSION JOINT LOCATION DETAILS

SCALE 1:20

TENDER DRAWING

NOT FOR CONSTRUCTION

THIS DRAWING HAS BEEN ISSUED FOR INFORMATION PURPOSES ONLY AND MUST NOT BE USED FOR CONSTRUCTION UNDER ANY CIRCUMSTANCES

- FOR SETTING OUT REFER TO ARCHITECT'S DRAWINGS.
- THIS DRAWING TO BE READ IN CONJUNCTION WITH ALL OTHER ARCHITECTURAL AND ENGINEERING DRAWINGS AND ALL OTHER RELEVANT DRAWINGS AND SPECIFICATIONS.
- DO NOT SCALE THIS DRAWING. USE FIGURED DIMENSIONS ONLY.
- NO PART OF THIS DOCUMENT MAY BE REPRODUCED OR TRANSMITTED IN ANY FORM OR STORED IN ANY RETRIEVAL SYSTEM OF ANY NATURE WITHOUT THE WRITTEN PERMISSION OF O'CONNOR SUTTON CRONIN AS COPYRIGHT HOLDER EXCEPT AS AGREED FOR USE ON THE PROJECT FOR WHICH THE DOCUMENT WAS ORIGINALLY ISSUED.

| Rev No. | Date | Revision Note | Drn by | Chkd by |
|---------|----------|-------------------|--------|---------|
| P01 | 03.03.23 | FOR INFORMATION | TD | TOD |
| P02 | 16.08.23 | ISSUED FOR TENDER | AD | TD |

| Rev No. | Date | Revision Note | Drn by | Chkd by |
|---------|------|---------------|--------|---------|
| | | | | |
| | | | | |

SLIGO COUNTY COUNCIL

OCSC

Client: SLIGO COUNTY COUNCIL

Project: ASH LANE GROUP HOUSING

Title: BOUNDARY WALL DETAILS

Second Floor Technology House Galway Technology Park Parkmore Galway

TEL +353 (0)91 771360

e: galway@ocsc.ie w: www.ocsc.ie

Dublin | London | Belfast | Galway | Cork

| Code | Originator | Zone | Level | Type | Role | Number | Status | Revision |
|----------------------|------------|------|-------|------|------|--------|--------|----------|
| S603-OCSC-XX-XX-DR-C | -0160 | D2 | P02 | | | | | |

Date: Mar '23 Scale: 1:20 @ A1 Drn by: AD Chkd by: TD Aprvd by:

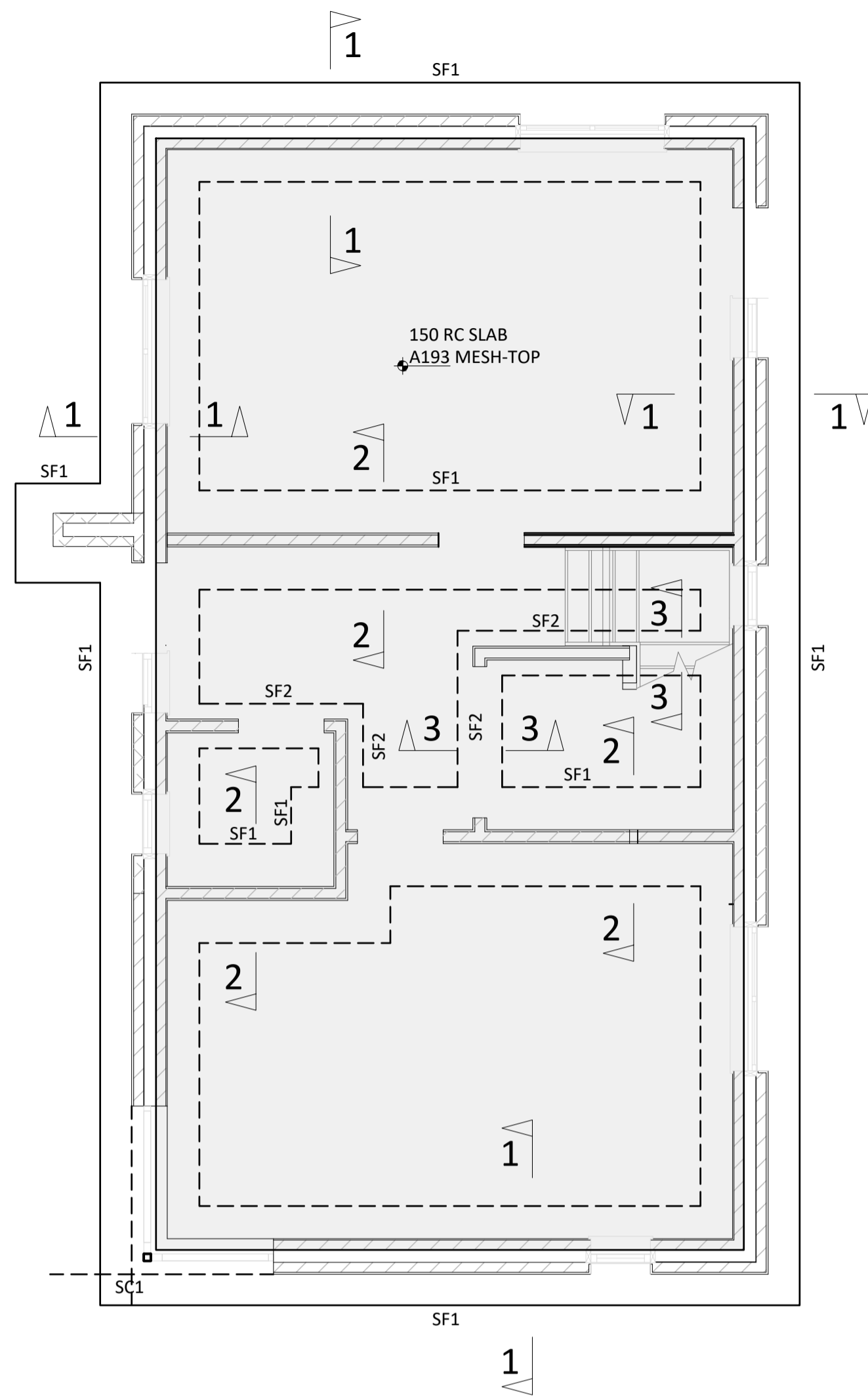

FOUNDATION / GROUND FLOOR PLAN - HOUSE TYPE A
SCALE 1:50

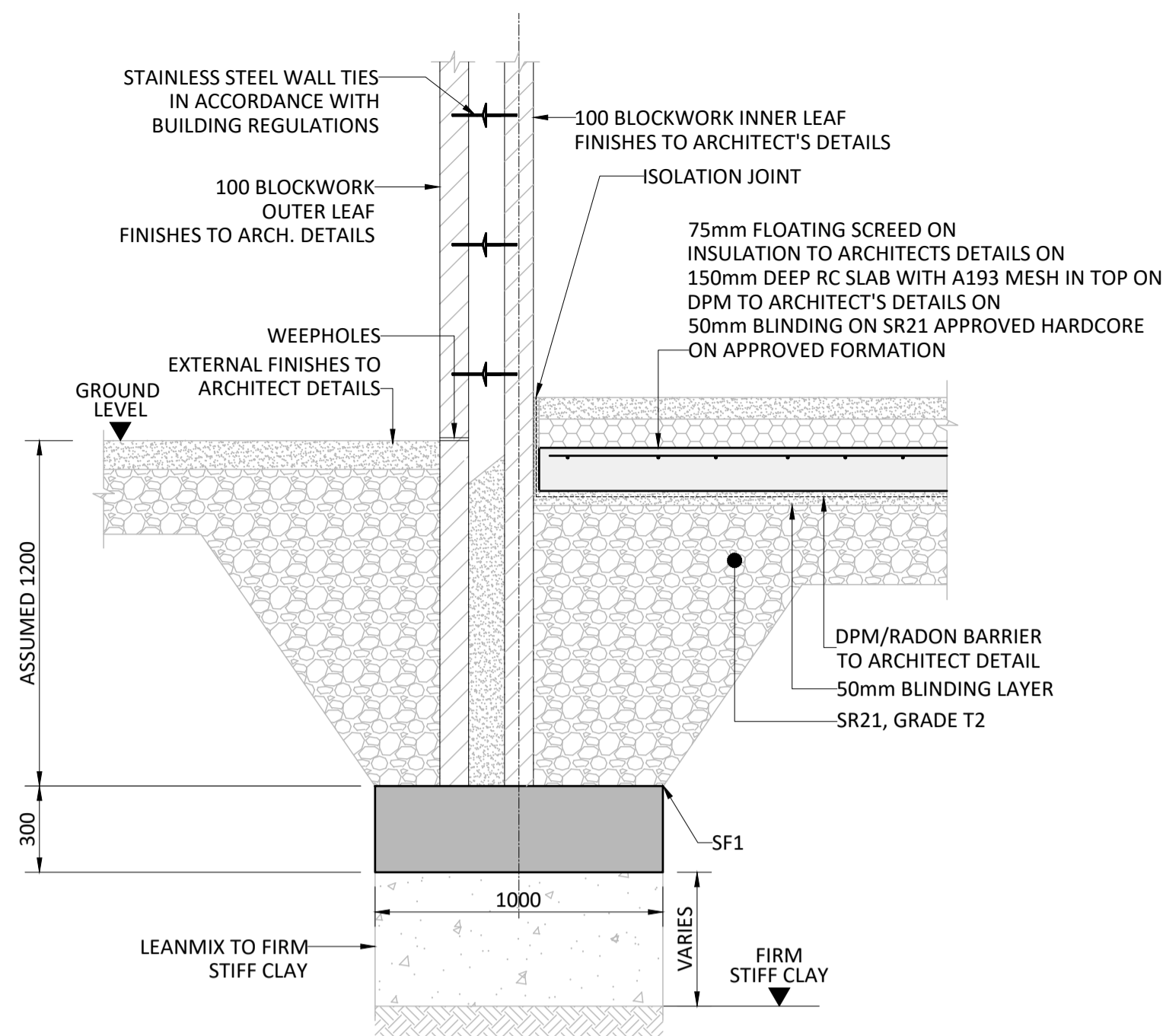

SECTION 1-1
SCALE 1:20

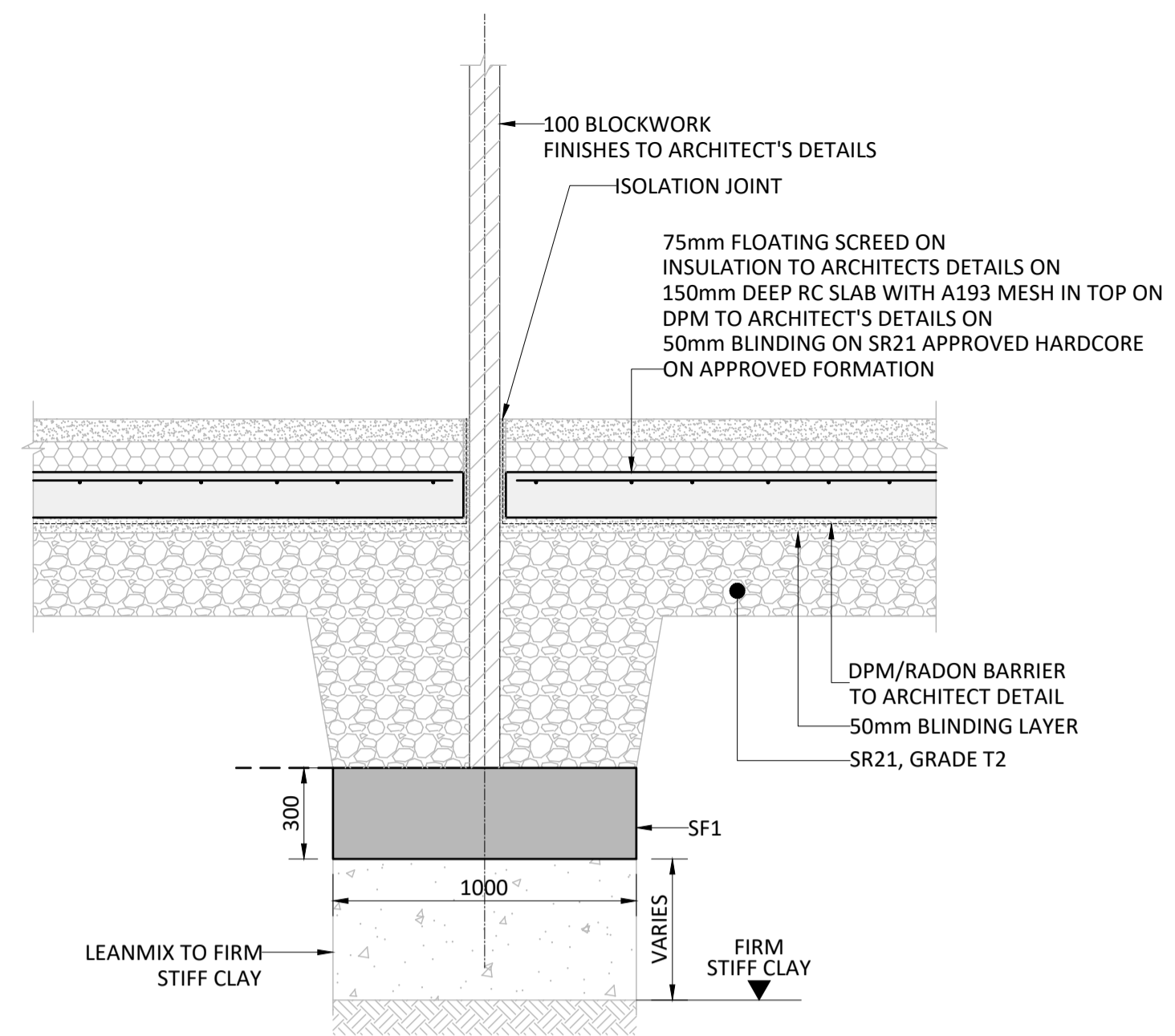

SECTION 2-2
SCALE 1:20

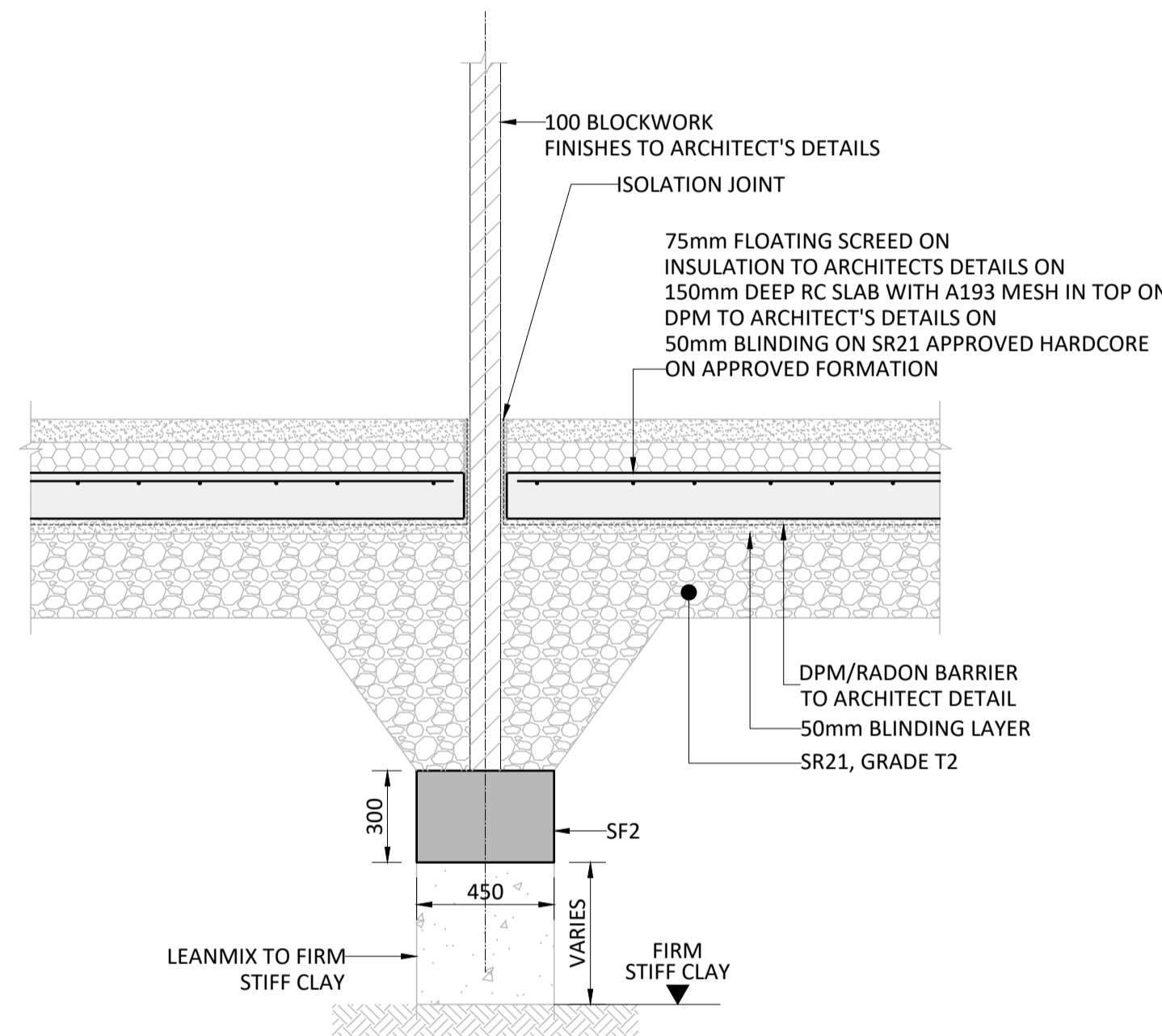

SECTION 3-3
SCALE 1:20

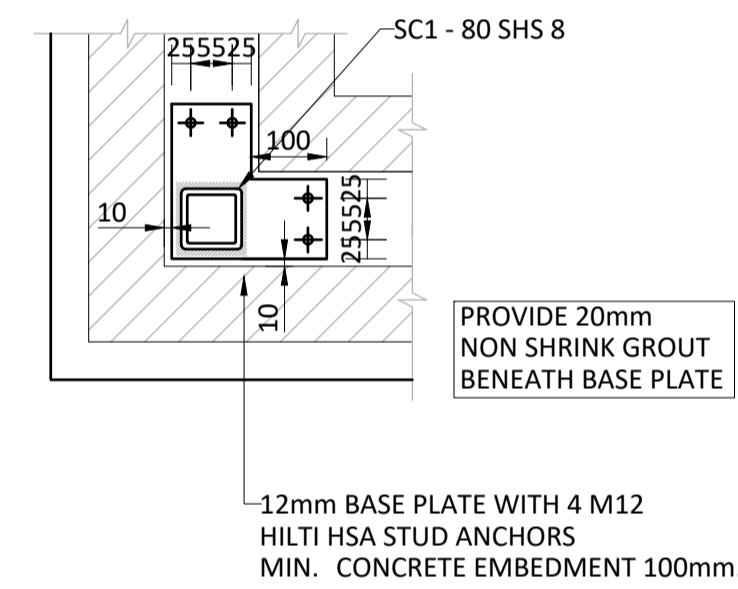

SC1 - HOLDING DOWN BOLT DETAIL
SCALE 1:10

LEGEND:

- CONCRETE BLOCKWORK
- STONE CLADDING BY ARCHITECT

FOUNDATION LEGEND:

- SF1 = 1000x300mm DEEP STRIP FOOTING WITH A393 MESH BOTTOM
- SF2 = 450x300mm DEEP STRIP FOOTING WITH A393 MESH BOTTOM

NOTE: BLOCKWORK

- 1...USE SOLID CONCRETE BLOCKS (THICKNESS SHOWN ON PLANS). REFER TO ARCHITECT'S SPECIFICATION FOR REQUIRED FINISH TO ALL BLOCKWORK.
- 2...PROVIDE A MIN. DECLARED MEAN COMPRESSIVE STRENGTH OF 7.5N/mm² BLOCKWORK IN ACCORDANCE WITH IS EN 771-3, LAID IN M4 MORTAR GRADE IN ACCORDANCE WITH SR. 325+A1-2014.
- 3...MASONRY WALLS TO BE BUILT NO HIGHER THAN 1.5M IN ANY ONE DAY.
- 4...REFER TO OCSC TECHNICAL SPECIFICATION FOR LOAD BEARING MASONRY FOR ADDITIONAL NOTES AND REQUIREMENTS.
- 5...LOCATION AND DETAILS OF CONTROL JOINTS IN ALL MASONRY SHALL BE AGREED WITH THE ENGINEER, ARCHITECT AND CONTRACTOR. FOR MEASUREMENT PURPOSES, PROVIDE JOINTS @12m CRS GENERALLY IN BRICKWORK EXTERNAL LEAVES AND @6m CRS GENERALLY IN BLOCKWORK EXTERNAL LEAVES.
- 6...EXPANSION JOINTS IN MASONRY SHALL BE FORMED USING 12mm THICK 'HYDROCELL' OR SIMILAR COMPRESSIBLE FILLER BOARD AND HIGH GRADE PROPRIETARY MASTIC SEALANT (TO ARCHITECTS SPECIFICATION) AND TAPE BOND BREAKER.

STEEL LEGEND:

- SC1 = 80 SHS 8 (GALVANISED POST)

- THIS DRAWING TO BE READ IN CONJUNCTION WITH ALL OTHER RELEVANT DESIGN TEAM DRAWINGS AND SPECIFICATIONS.
- FOR SETTING OUT REFER TO ARCHITECT'S DRAWINGS. DO NOT SCALE THIS DRAWING. USE FIGURED DIMENSIONS ONLY.
- NO PART OF THIS DOCUMENT MAY BE REPRODUCED OR TRANSMITTED IN ANY FORM OR STORED IN ANY RETRIEVAL SYSTEM OF ANY NATURE WITHOUT THE WRITTEN PERMISSION OF O'CONNOR SUTTON CRONIN AS COPYRIGHT HOLDER EXCEPT AS AGREED FOR USE ON THE PROJECT FOR WHICH THE DOCUMENT WAS ORIGINALLY ISSUED.

| Rev No. | Date | Revision Note | Drn by | Chkd by |
|---------|----------|--------------------------|--------|---------|
| P01 | 23.06.23 | SUITABLE FOR INFORMATION | PT | TK |
| P02 | 06.07.23 | SUITABLE FOR INFORMATION | PT | TK |

| Rev No. | Date | Revision Note | Drn by | Chkd by |
|---------|------|---------------|--------|---------|
| | | | | |
| | | | | |
| | | | | |
| | | | | |

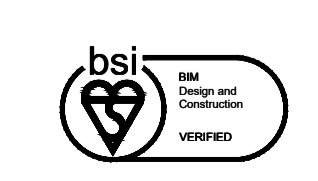

OCSC
O'CONNOR · SUTTON · CRONIN
MULTIDISCIPLINARY CONSULTING ENGINEERS
Civil / Structural / Environmental / Mechanical / Electrical / Sustainability
Galway Office: Technology House, Galway Technology Park, Parkmore, Galway.
Tel: +353 (0)91 771360 Web: www.ocsc.ie
Dublin · London · Belfast · Galway · Cork · Birmingham

Client: SLIGO CO. CO.
Project: ASH LANE GROUP HOUSING

Title: GENERAL ARRANGEMENT
GROUND FLOOR PLAN
HOUSE TYPE A

| Code | Originator | Zone | Level | Type | Role | Number | Status | Revision |
|------|------------|------|-------|------|------|--------|--------|----------|
| S603 | OCSC | XX | 00 | DR | S | 1500 | S2 | P02 |

Date: 19.06.23 Scale @ A1: NOTED Drn by: PT Chkd by: TK Aprvd by: TK

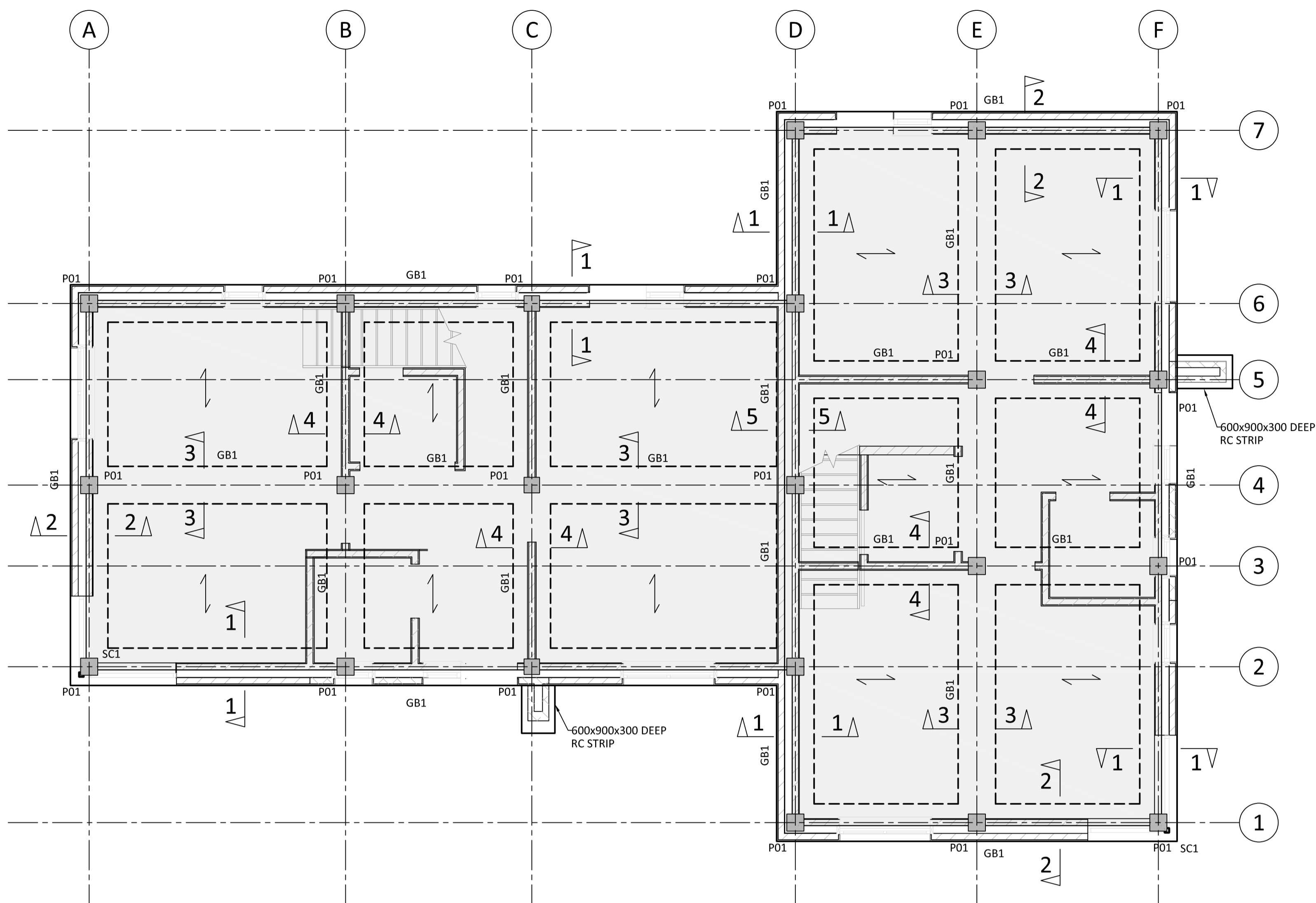

FOUNDATION / GROUND FLOOR PLAN - HOUSE TYPE B
SCALE 1:50

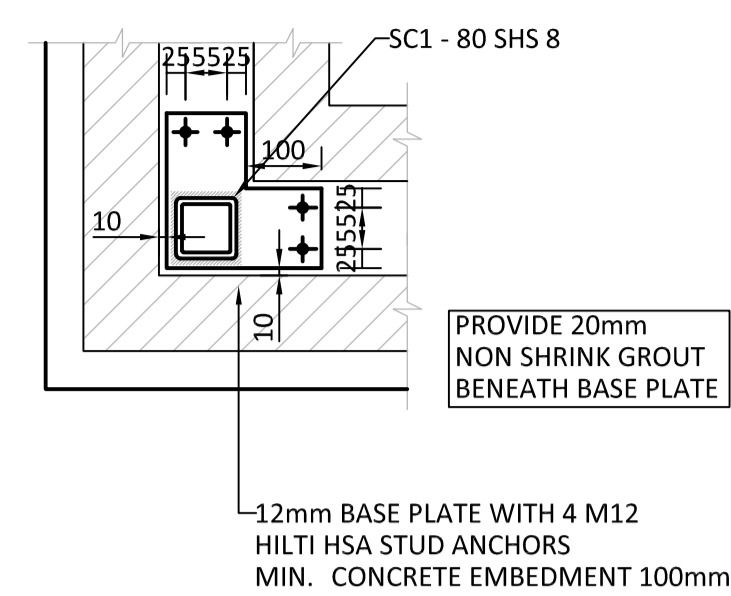

SC1 - HOLDING DOWN BOLT DETAIL
SCALE 1:10

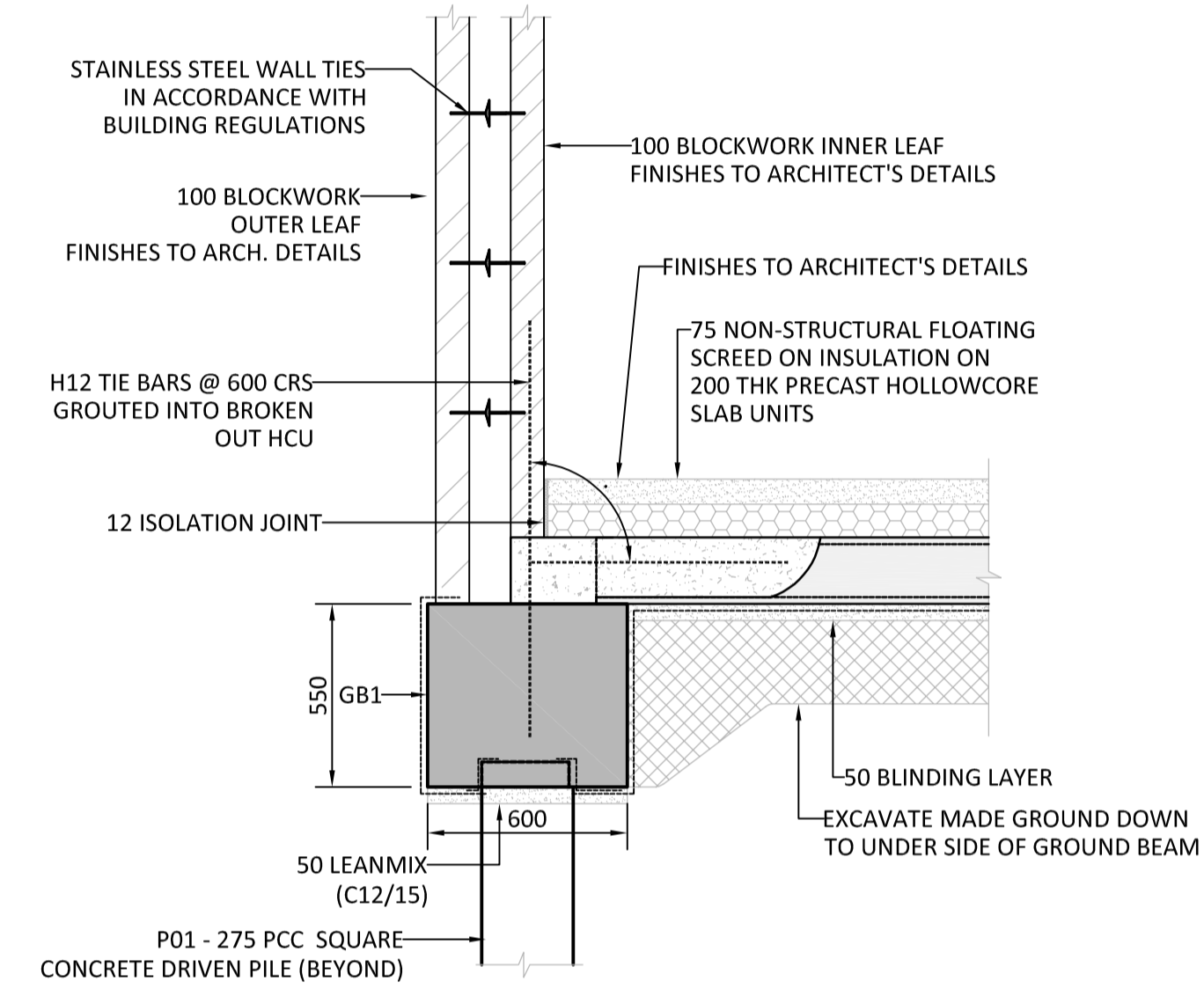

SECTION 1-1
SCALE 1:20

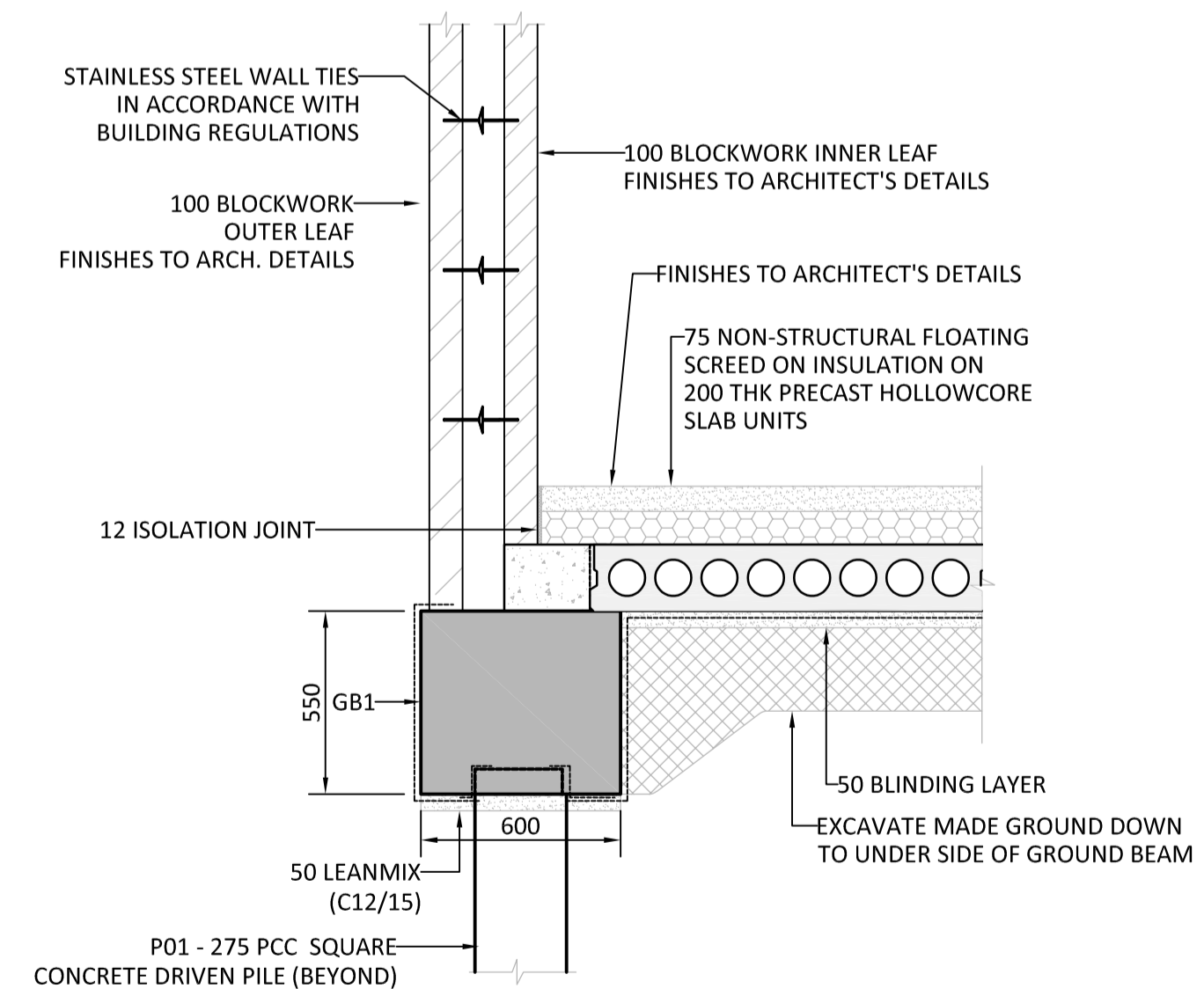

SECTION 2-2
SCALE 1:20

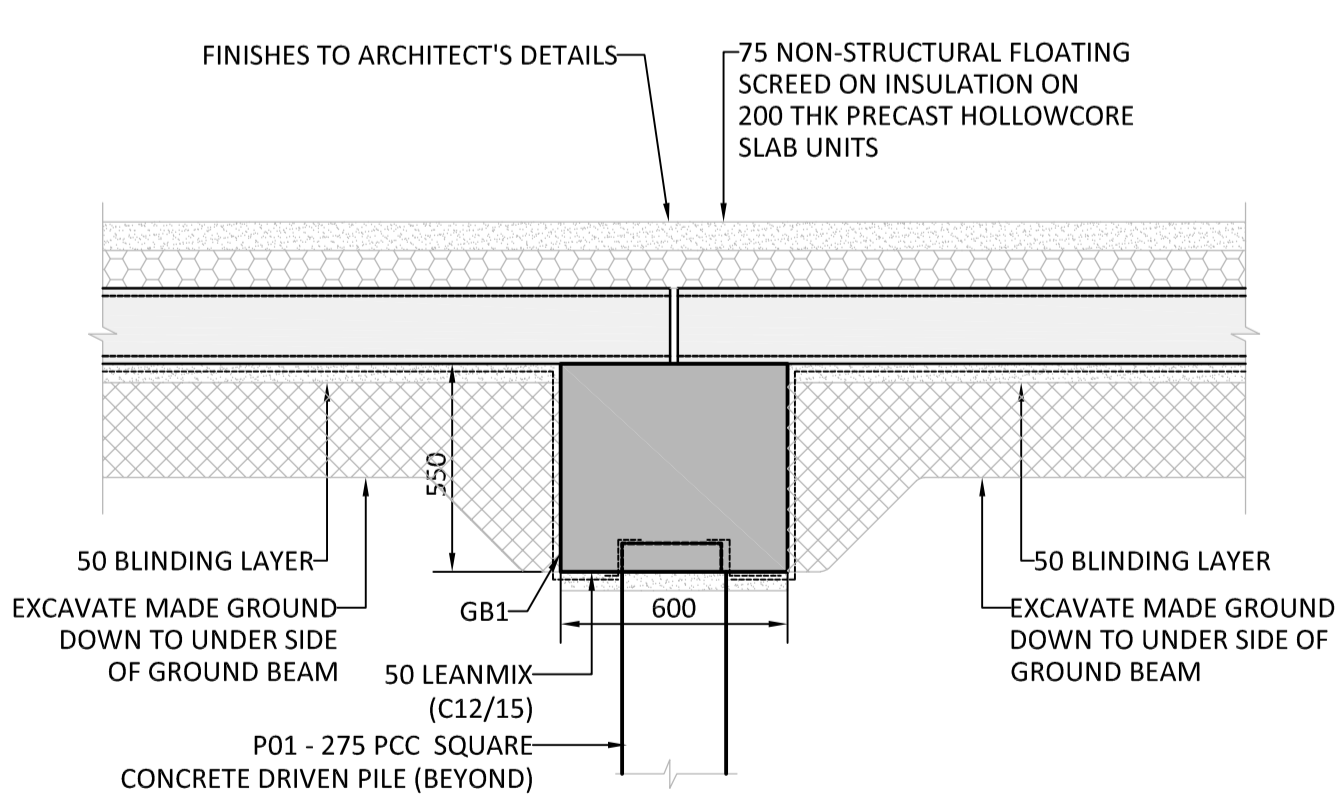

SECTION 3-3
SCALE 1:20

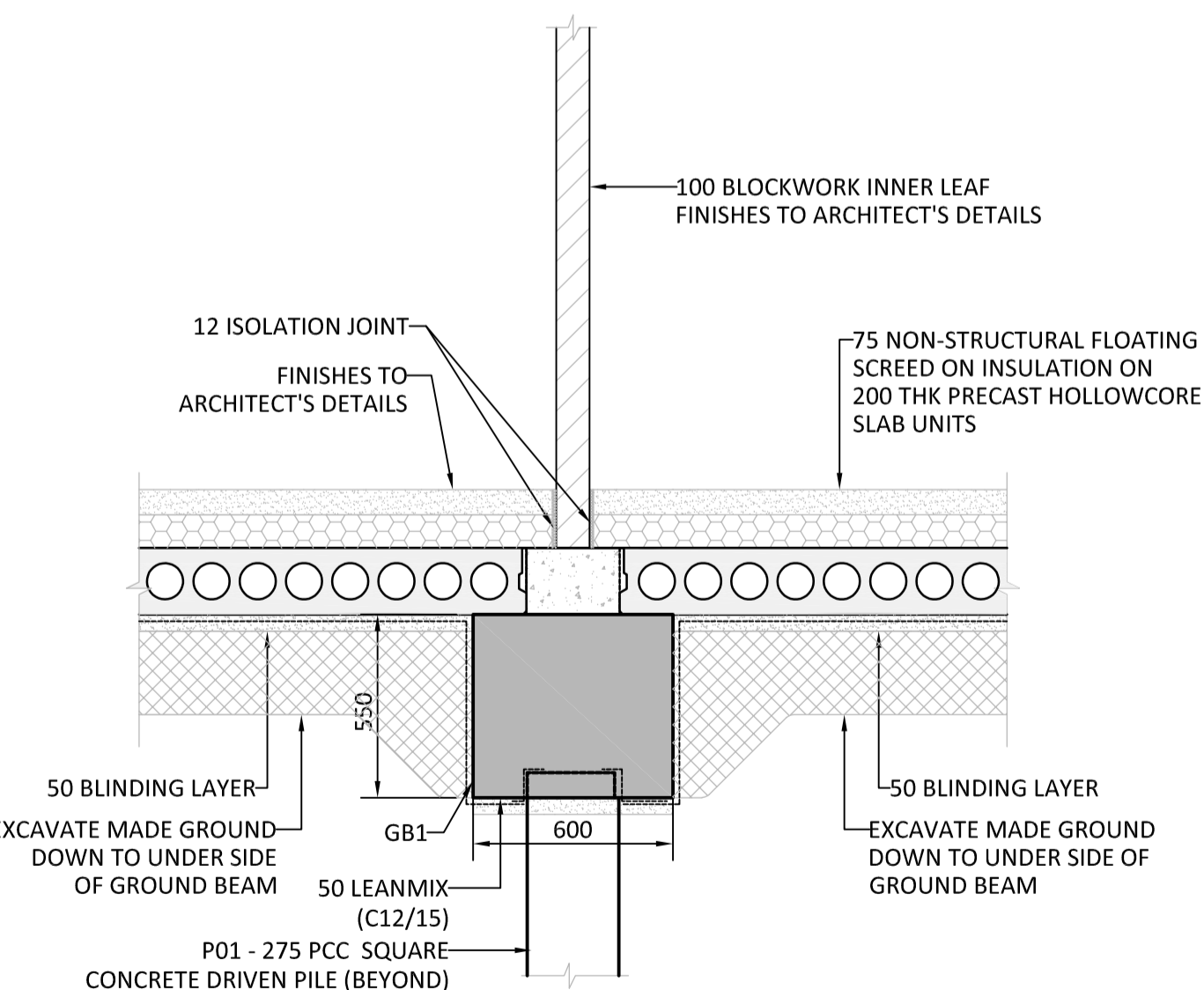

SECTION 4-4
SCALE 1:20

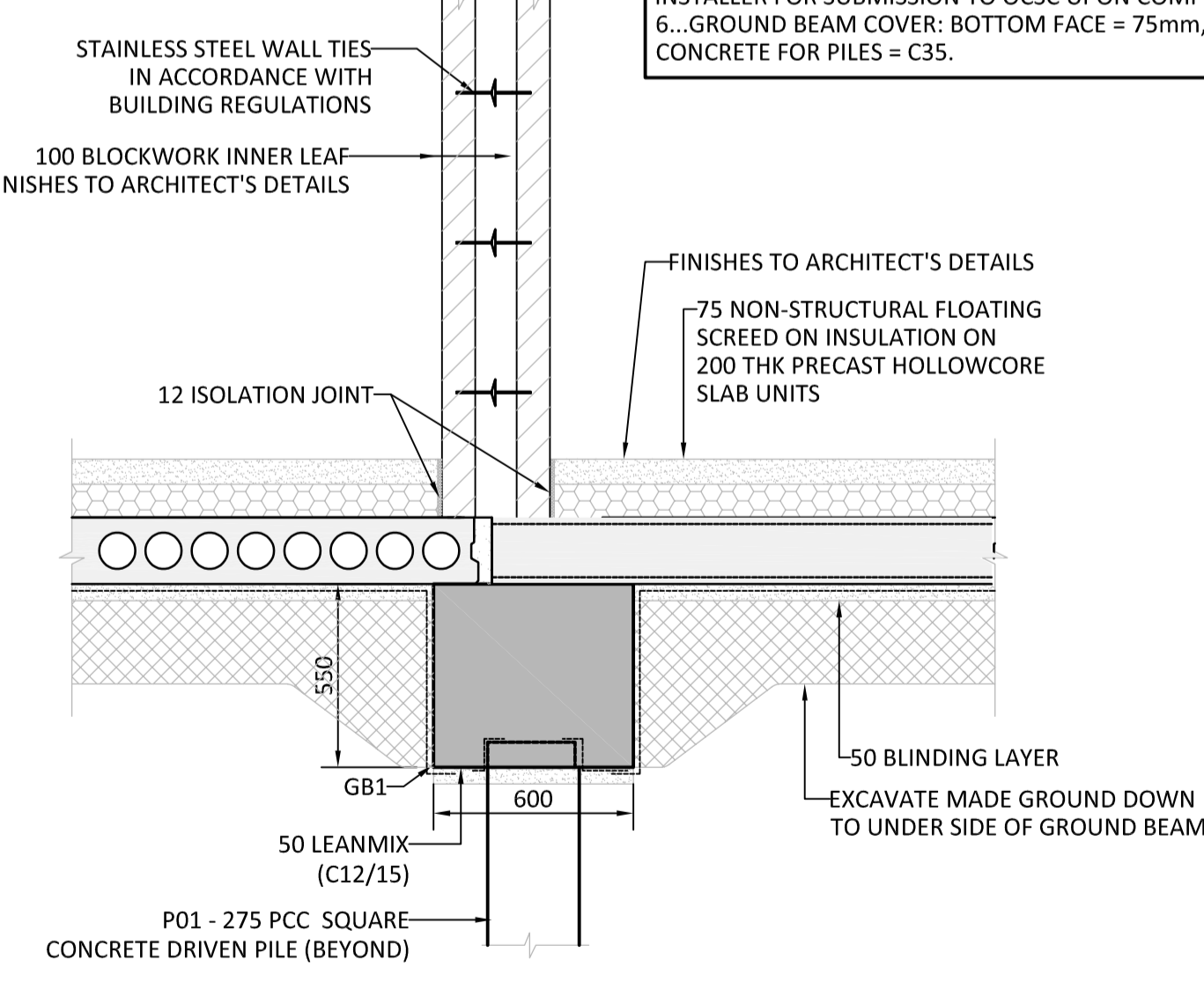

SECTION 5-5
SCALE 1:20

LEGEND:

- CONCRETE BLOCKWORK
- STONE CLADDING BY ARCHITECT
- 75 NON STRUCTURAL SCREED ON 200 PRECAST HOLLOWCORE UNITS

FOUNDATION LEGEND:

- P01 = 250 SQUARE PILE - REFER TO NOTE 'A'
- GB1 = 600x550 DEEP RC GROUND BEAM

NOTE: BLOCKWORK

- 1...USE SOLID CONCRETE BLOCKS (THICKNESS SHOWN ON PLANS). REFER TO ARCHITECT'S SPECIFICATION FOR REQUIRED FINISH TO ALL BLOCKWORK.
- 2...PROVIDE A MIN. DECLARED MEAN COMPRESSIVE STRENGTH OF 7.5N/mm² BLOCKWORK IN ACCORDANCE WITH IS EN 771-3, LAID IN M4 MORTAR GRADE IN ACCORDANCE WITH SR. 325+A1-2014.
- 3...MASONRY WALLS TO BE BUILT NO HIGHER THAN 1.5M IN ANY ONE DAY.
- 4...REFER TO OCS TECHNICAL SPECIFICATION FOR LOAD BEARING MASONRY FOR ADDITIONAL NOTES AND REQUIREMENTS.
- 5...LOCATION AND DETAILS OF CONTROL JOINTS IN ALL MASONRY SHALL BE AGREED WITH THE ENGINEER, ARCHITECT AND CONTRACTOR. FOR MEASUREMENT PURPOSES, PROVIDE JOINTS @12m CRS GENERALLY IN BRICKWORK EXTERNAL LEAVES AND @6m CRS GENERALLY IN BLOCKWORK EXTERNAL LEAVES.
- 6...EXPANSION JOINTS IN MASONRY SHALL BE FORMED USING 12mm THICK 'HYDROCELL' OR SIMILAR COMPRESSIBLE FILLER BOARD AND HIGH GRADE PROPRIETY MASTIC SEALANT (TO ARCHITECTS SPECIFICATION) AND TAPE BOND BREAKER.
- 7...AT THE LOCATION OF THE MOVEMENT JOINT, DOUBLE STRUCTURE TO BE PROVIDED.

STEEL LEGEND:

- SC1 = 80 SHS 8 (GALVAISED POST)

NOTE:

- PILE LENGTH = 9.0m IS BASED ON SITE INVESTIGATION REPORT

NOTE A - PILING: GENERAL REQUIREMENT:

- 1...ALL PILES TO BE DESIGNED BY SPECIALIST SUB-CONTRACTOR FOR THE FOLLOWING DESIGN CRITERIA:
 - MINIMUM SAFE WORKING LOAD PER PILE = 350KN
 - GROUT STRESS TO BE LIMITED TO 0.25fcu
 - REQUIRED FACTOR OF SAFETY = 2.5
- 2...PILE DEPTH OF APPROXIMATE 7.5M (SUBJECT TO FURTHER SITE INVESTIGATION STUDY) PLEASE REFER TO THE SITE INVESTIGATION REPORT CARRIED OUT BY CAUSEWAY GEOTECH FOR INFORMATION ON GROUND CONDITIONS, ASSOCIATED TESTS THAT ACCOMPANIES THIS TENDER OR RELEVANT INFORMATION RELATING TO THE GROUND CONDITIONS. CALCULATIONS WILL BE REQUIRED TO BE SUBMITTED IN ADVANCE OF THE WORKS BY THE MAIN CONTRACTORS SPECIALIST PILE DESIGNER FOR OCS APPROVAL PRIOR TO INSTALLATION OF THE PILE SYSTEM.
- 3...ALL PILES TO BE REINFORCED CONCRETE ROTARY BORED PILES OF A MINIMUM 250 SQUARE PROVIDED WITH A MINIMUM ROCK SOCKET OF 4x PILE DIAMETER INTO SOUND COMPETENT ROCK.
- 4...PRELIMINARY DESIGN CALCULATIONS INDICATES THAT A 250 SQUARE PILE IS SUITABLE FOR USE. WHILE TENDERERS MAY PROPOSE ALTERNATIVE PILE SIZES, PLEASE BE ADVISED THAT ADDITIONAL FEES WILL BE CHARGED BY OCS DIRECTLY TO THE SUCCESSFUL MAIN CONTRACTOR FOR ANY AMENDMENTS REQUIRED TO BE CARRIED OUT TO BOTH STRUCTURAL GENERAL ARRANGEMENTS AND REINFORCEMENT DRAWINGS AS RESULT OF AN ALTERNATIVE PROPOSED PILE DIAMETER BEING USED.
- 5...PILE TESTING TO BE CARRIED OUT IN ACCORDANCE WITH BS8004 AND TO CONSIST OF THE FOLLOWING:
 - ALL PILES TO BE INTEGRITY TESTED
 - 10% OF PILES TO BE DYNAMICALLY TESTED
 - KENTLEDGE TEST TO BE CARRIED OUT ON 2No. PILES.
- 6...LOCATION OF DYNAMIC AND KENTLEDGE PILES TO BE AGREED WITH OCS UPON SUCCESSFUL INSTALLATION OF ALL PILES.
- 7...REFER TO OCS TECHNICAL SPECIFICATION ON PILING FOR ALL OTHER DESIGN AND WORKS REQUIREMENTS (INCLUDING RECORDS TO BE TAKEN AND SUBMITTED BY THE SPECIALIST PILE INSTALLER FOR SUBMISSION TO OCS UPON COMPLETION).
- 8...GROUND BEAM COVER: BOTTOM FACE = 75mm, SIDE AND TOP = 40mm. GRADE OF CONCRETE FOR PILES = C35.

- THIS DRAWING TO BE READ IN CONJUNCTION WITH ALL OTHER RELEVANT DESIGN TEAM DRAWINGS AND SPECIFICATIONS.
- FOR SETTING OUT REFER TO ARCHITECT'S DRAWINGS. DO NOT SCALE THIS DRAWING. USE FIGURED DIMENSIONS ONLY.
- NO PART OF THIS DOCUMENT MAY BE REPRODUCED OR TRANSMITTED IN ANY FORM OR STORED IN ANY RETRIEVAL SYSTEM OF ANY NATURE WITHOUT THE WRITTEN PERMISSION OF O'CONNOR SUTTON CRONIN AS COPYRIGHT HOLDER EXCEPT AS AGREED FOR USE ON THE PROJECT FOR WHICH THE DOCUMENT WAS ORIGINALLY ISSUED.

| Rev No. | Date | Revision Note | Drn by | Chkd by |
|---------|----------|--------------------------|--------|---------|
| P01 | 23.06.23 | SUITABLE FOR INFORMATION | PT | TK |
| P02 | 06.07.23 | SUITABLE FOR INFORMATION | PT | TK |
| P03 | 19-07-23 | SUITABLE FOR INFORMATION | PT | TK |
| P04 | 12.08.23 | SUITABLE FOR INFORMATION | PT | TK |

| Rev No. | Date | Revision Note | Drn by | Chkd by |
|---------|------|---------------|--------|---------|
| | | | | |
| | | | | |
| | | | | |



OCSC
O'CONNOR SUTTON CRONIN
MULTIDISCIPLINARY CONSULTING ENGINEERS
Civil / Structural / Environmental / Mechanical / Electrical / Sustainability
Galway Office: Technology House, Galway Technology Park, Parkmore, Galway.
Tel: +353 (0)91 771360 Web: www.ocsc.ie
Dublin · London · Belfast · Galway · Cork · Birmingham

Client: SLIGO CO. CO.
Project: ASH LANE GROUP HOUSING
Title: GENERAL ARRANGEMENT GROUND FLOOR PLAN HOUSE TYPE B
Code | Originator | Zone | Level | Type | Role | Number | Status | Revision
S603 · OCSC · XX · 00 · DR · S · 1550 · S2 · P04
Date:19.06.23Scale @ A1:NOTED Drn by:PT Chkd by:TK Aprvd by:AMcD



OCSC

O'CONNOR | SUTTON | CRONIN

Multidisciplinary
Consulting Engineers

Second Floor, Technology House
Galway Technology Park
Parkmore, Galway, H91 TXKO

T | +353 (0)91771360
E | contactus@ocsc.ie
W | www.ocsc.ie

Dublin | Cork | Galway | Belfast | Birmingham | London